

TECHNICAL MANUAL

**UNIT MAINTENANCE MANUAL
(INCLUDING REPAIR PARTS AND SPECIAL TOOLS LIST)**

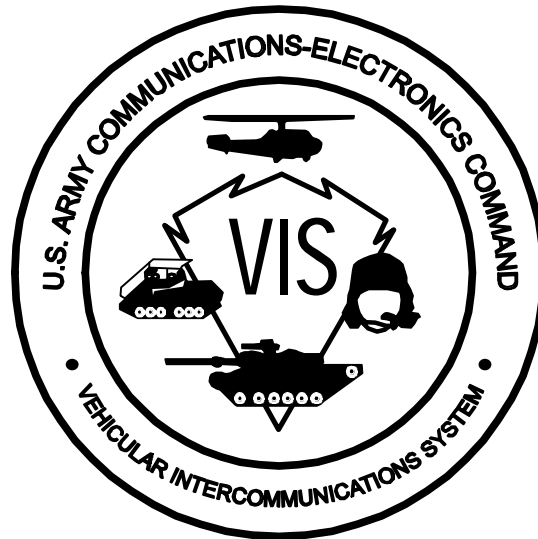

**INTERCOMMUNICATION SET, VEHICULAR
AN/VIC-3(V), INCLUDING:**

Control, Indicator CD-82/VRC

(NSN 5895-01-382-3221) (EIC: NA)

Control, Intercommunication Set C-12357/VRC

(NSN 5830-01-382-3218) (EIC: NA)

Control, Intercommunication Set C-12358/VRC

(NSN 5830-01-382-3209) (EIC: NA)

Interface Unit, Communication Equipment C-12359/VRC

(NSN 5895-01-382-3220) (EIC: NA)

Loudspeaker, Permanent Magnet LS-688/VRC

(NSN 5965-01-382-3222) (EIC: NA)

Approved for public release; distribution is unlimited.
**DESTRUCTION NOTICE -- Destroy by any method that will prevent
disclosure of contents or reconstruction of the document**

**HEADQUARTERS, DEPARTMENT OF THE ARMY
1 APRIL 2000**

TM 11-5830-263-20&P

LIST OF EFFECTIVE PAGES/WORK PACKAGES

Dates of issue for the original manual and changed pages/work packages are:

Original 1 Apr 00

TOTAL NUMBER OF PAGES FOR FRONT AND REAR MATTER IS 13 AND TOTAL NUMBER OF WORK PACKAGES IS 0, CONSISTING OF THE FOLLOWING:

Page/WP No.	*Change No.	Page/WP No.	*Change No.
Title	0	RPSTL Fig 8 (2 pgs)	0
Warnings (3 pgs)	0	RPSTL Fig 9 (2 pgs)	0
i thru iv	0	RPSTL Fig 10 (4 pgs)	0
1-0 thru 1-10	0	RPSTL Fig 11 (2 pgs)	0
2-1 thru 2-66	0	RPSTL Fig 12 (4 pgs)	0
3-1 thru 3-33	0	RPSTL Fig 13 (4 pgs)	0
A-1 and A-2	0	RPSTL Fig 14 (2 pgs)	0
B-1 thru B-9	0	RPSTL Fig 15 (3 pgs)	0
C-1 thru C-8	0	RPSTL Indexes (10 pgs)	0
RPSTL Fig 1 (19 pgs)	0	D-1 and D-2	0
RPSTL Fig 2 (2 pgs)	0	E-1 and E-2	0
RPSTL Fig 3 (2 pgs)	0	F-1 and F-2	0
RPSTL Fig 4 (2 pgs)	0	G-1 and G-2	0
RPSTL Fig 5 (2 pgs)	0	H-1 thru H14	0
RPSTL Fig 6 (2 pgs)	0	J-1 and J-2	0
RPSTL Fig 7 (4 pgs)	0		

* Zero in this column indicates an original page.



5

SAFETY STEPS TO FOLLOW IF SOMEONE IS THE VICTIM OF ELECTRICAL SHOCK

1

DO NOT TRY TO PULL OR GRAB THE INDIVIDUAL

2

IF POSSIBLE, TURN OFF THE ELECTRICAL POWER

3

IF YOU CANNOT TURN OFF THE ELECTRICAL POWER, PULL, PUSH, OR LIFT THE PERSON TO SAFETY USING A DRY WOODEN POLE OR A DRY ROPE OR SOME OTHER INSULATING MATERIAL

4

SEND FOR HELP AS SOON AS POSSIBLE

5

AFTER THE INJURED PERSON IS FREE OF CONTACT WITH THE SOURCE OF ELECTRICAL SHOCK, MOVE THE PERSON A SHORT DISTANCE AWAY AND IMMEDIATELY START ARTIFICIAL RESUSCITATION

WARNING

HIGH VOLTAGE

IS USED IN THE OPERATION OF THIS EQUIPMENT.

DEATH ON CONTACT

MAY RESULT IF PERSONNEL FAIL TO OBSERVE SAFETY PRECAUTIONS.

NEVER WORK ON ELECTRONIC EQUIPMENT UNLESS THERE IS ANOTHER PERSON NEARBY WHO IS FAMILIAR WITH THE OPERATION AND HAZARDS OF THE EQUIPMENT AND WHO IS COMPETENT IN ADMINISTERING FIRST AID. WHEN THE TECHNICIAN IS AIDED BY OPERATORS, THEY MUST BE WARNED ABOUT DANGEROUS AREAS.

BE CAREFUL NOT TO CONTACT HIGH-VOLTAGE CONNECTIONS OF THE AC INPUT CONNECTIONS WHEN INSTALLING OR OPERATING THIS EQUIPMENT.

WHENEVER THE NATURE OF THE OPERATION PERMITS, KEEP ONE HAND AWAY FROM THE EQUIPMENT TO REDUCE THE HAZARD OF CURRENT FLOWING THROUGH VITAL ORGANS OF THE BODY.

WARNING

DO NOT BE MISLED BY THE TERM "LOW VOLTAGE". POTENTIALS AS LOW AS 30 VOLTS MAY CAUSE DEATH UNDER CERTAIN CONDITIONS.

FOR ARTIFICIAL RESPIRATION, REFER TO FM 21-11.

WARNING

WHEN LISTENING TO THE VIS RADIO HEADSET WITH THE OPERATOR VOLUME CONTROLS SETTING IN THE RED ZONE CLICK STOP AT A FULL ON VOLUME SETTING, EXTREME CAUTION MUST BE EXERCISED TO PREVENT NOISE-INDUCED HEARING LOSS. EXPOSURES TO RADIO SIGNALS IN THE FULL ON POSITION BEYOND 45 SECONDS MAY CAUSE HEARING LOSS. ANY PROLONGED EXPOSURE IN THE FULL ON VOLUME CONTROL SETTING REQUIRES THE USE OF A SINGLE HEARING PROTECTIVE DEVICE IN EACH EAR.

WARNING

WHEN INSTALLING REPLACEMENT BATTERY IN THE CVC HELMET BATTERY COMPARTMENT, DO NOT PLACE ALKALINE AA BATTERY IN THE RECHARGEABLE SLOT. PLACE THE ALKALINE AA BATTERY IN THE ALKALINE SLOT ONLY. ALKALINE BATTERIES MAY EXPLODE OR LEAK IF RECHARGED OR CONNECTED IMPROPERLY.

WARNING

ALKALINE BATTERIES CONTAIN CAUSTIC KOH ELECTROLYTE, WHICH MAY LEAK IF THE BATTERY IS ABUSED. KOH IS A STRONG ALKALI SIMILAR TO CAUSTIC SODA (SODIUM HYDROXIDE). SERIOUS CHEMICAL BURNS CAN RESULT IF ELECTROLYTE COMES INTO CONTACT WITH THE SKIN OR EYES. IF THE BATTERY ELECTROLYTE GETS INTO YOUR EYES, IT CAN CAUSE SEVERE DAMAGE AND/OR BLINDNESS.

DO NOT TRY TO NEUTRALIZE CAUSTIC ELECTROLYTE WITH VINEGAR OR ANY OTHER ACIDIC SOLUTIONS. NEUTRALIZATION WILL DO MORE HARM THAN GOOD, AS IT WILL TRAP CAUSTIC UNDER THE SKIN, PREVENTING IT FROM COMING OUT. FLUSH WITH COPIOUS AMOUNTS OF COOL WATER.

Technical Manual

TM 11-5830-263-20&P

Headquarters
 Department of the Army
 Washington, D. C., 1 April 2000

UNIT MAINTENANCE MANUAL
(Including Repair Parts and Special Tools List)
INTERCOMMUNICATION SET, VEHICULAR
AN/VIC-3(V), INCLUDING
CONTROL, INDICATOR CD-82/VRC
(NSN 5895-01-382-3221) (EIC: NA)
CONTROL, INTERCOMMUNICATION SET C-12357/VRC
(NSN 5830-01-382-3218) (EIC: NA)
CONTROL, INTERCOMMUNICATION SET C-12358/VRC
(NSN 5830-01-382-3209) (EIC: NA)
INTERFACE UNIT, COMMUNICATION EQUIPMENT C-12359/VRC
(NSN 5895-01-382-3220) (EIC: NA)
LOUDSPEAKER, PERMANENT MAGNET LS-688/VRC
(NSN 5965-01-382-3222) (EIC: NA)

REPORTING ERRORS AND RECOMMENDING IMPROVEMENTS

You can help improve this manual. If you find any mistakes, or if you know of a way to improve the procedures, please let us know. Mail your letter, DA Form 2028 (Recommended Changes to Publications and Blank Forms) or DA Form 2028-2 located in back of this manual direct to: Commander, US Army Communications-Electronics Command and Fort Monmouth, ATTN: AMSEL-LC-LEO-D-CS-CFO, Fort Monmouth, New Jersey 07703-5007. The fax number is 732-532-1413, DSN 992-1413. You may also e-mail your recommendations to AMSEL-LC-LEO-PUBS-CHG@cecom3.monmouth.army.mil

In either case a reply will be furnished direct to you.

TABLE OF CONTENTS

	Page
HOW TO USE THIS MANUAL.....	v
CHAPTER 1 INTRODUCTION.....	1-1
SECTION I General Information	1-1
SECTION II Equipment Description and Data.....	1-4
SECTION III Principles of Operation.....	1-7
CHAPTER 2 UNIT TROUBLESHOOTING PROCEDURES.....	2-1
SECTION I General Troubleshooting Inspection.....	2-1
SECTION II Equipment Location and System Configuration Diagrams	2-2
SECTION III FFCS and RIT Crew Station/Radio Switch Setting Procedures.....	2-40
SECTION IV System Troubleshooting with No Error Shown on Display.....	2-42
SECTION V System Troubleshooting with Error Shown on Display.....	2-59
SECTION VI Troubleshooting of Cable Assemblies	2-66

TABLE OF CONTENTS (CONTINUED)

	Page
CHAPTER 3 UNIT MAINTENANCE INSTRUCTIONS.....	3-1
SECTION I General Information	3-1
SECTION II LRU Removal and Replacement Procedures	3-1
SECTION III Headset(s) Components Removal and Replacement Procedures.....	3-12
SECTION IV Cable Removal and Replacement.....	3-30
SECTION V LRU Knob(s) Removal and Replacement Procedures	3-31
SECTION VI Preparation for Storage and Shipment	3-33
APPENDIX A REFERENCES	A-1
APPENDIX B MAINTENANCE ALLOCATION CHART (MAC).....	B-1
SECTION I Introduction.....	B-1
SECTION II Maintenance Allocation Chart.....	B-4
SECTION III Tools and Test Equipment Requirements.....	B-7
SECTION IV Remarks for AN/VIC-3(V) Vehicular Intercommunication Set.....	B-8
APPENDIX C Unit Maintenance Repair Parts and Special Tools List (RPSTL).....	C-1
SECTION I Introduction.....	C-2
SECTION II Repair Parts List	C-10
SECTION III Special Tools (not applicable)	
SECTION IV Cross Reference Indexes.....	C-1-1
APPENDIX D Components of End Item and Basic Issue Items List.....	D-1
APPENDIX E ADDITIONAL AUTHORIZATION LIST.....	E-1
SECTION I Introduction.....	E-1
SECTION II Additional Authorization List	E-2
APPENDIX F EXPENDABLE/DURABLE SUPPLIES AND MATERIALS LIST	F-1
SECTION I Introduction.....	F-1
SECTION II Expendable/Durable Supplies and Materials	F-2
APPENDIX G ACRONYMS AND TERMS	G-1
APPENDIX H CABLE ASSEMBLY, CONNECTOR PIN IDENTIFICATION AND SIGNAL NAMES..	H-1
List of Cable Numbers and Common Names.....	H-1
APPENDIX J AN/VIC-3(V) TRAINING INTERFACE DEVICES	J-1

LIST OF ILLUSTRATIONS

Figure	Title	Page
Figure 1-1.	AN/VIC-3(V) Line Replaceable Units	1-0
Figure 1-2.	Highway Cable Construction	1-8
Figure 2-1.	M1A1 ABRAMS Equipment Location Diagram.....	2-4
Figure 2-2.	M1A1 ABRAMS System Configuration Diagram	2-5
Figure 2-3.	M1A2 ABRAMS Equipment Location Diagram.....	2-6
Figure 2-4.	M1A2 ABRAMS System Configuration Diagram	2-7
Figure 2-5.	M2A2 BRADLEY Equipment Location Diagram	2-8
Figure 2-6.	M2A2 BRADLEY System Configuration Diagram.....	2-9
Figure 2-7.	M3A2 BRADLEY Equipment Location Diagram	2-10
Figure 2-8.	M3A2 BRADLEY System Configuration Diagram.....	2-11
Figure 2-9.	M577 Equipment Location Diagram.....	2-12
Figure 2-10.	M577 System Configuration Diagram	2-13
Figure 2-11.	M109A6 PALADIN Equipment Location Diagram.....	2-14
Figure 2-12.	M109A6 PALADIN System Configuration Diagram	2-15
Figure 2-13.	M1068 SICPS, Tracked Equipment Location Diagram	2-16
Figure 2-14.	M1068 SICPS, Tracked System Configuration Diagram.....	2-17
Figure 2-15.	S-787 SICPS, Shelter Equipment Location Diagram	2-18
Figure 2-16.	S-787 SICPS, Shelter System Configuration Diagram	2-19
Figure 2-17.	M2A2 ODS Bradley Equipment Location Diagram	2-20
Figure 2-18.	M2A2 ODS Bradley System Configuration Diagram.....	2-21
Figure 2-19.	M3A2 ODS Bradley Equipment Location Diagram	2-22
Figure 2-20.	M3A2 ODS Bradley System Configuration Diagram	2-23
Figure 2-21.	HAB Equipment Location Diagram	2-24
Figure 2-22.	HAB System Configuration Diagram.....	2-25
Figure 2-23.	M992 FAASV Equipment Location Diagram	2-26
Figure 2-24.	M992 FAASV System Configuration Diagram.....	2-27
Figure 2-25.	M7 BFIST Equipment Location Diagram.....	2-28
Figure 2-26.	M7 BFIST System Configuration Diagram	2-29
Figure 2-27.	M88A2 Recovery Vehicle Equipment Location Diagram	2-30
Figure 2-28.	M88A2 Recovery Vehicle System Configuration Diagram.....	2-31
Figure 2-29.	ASV Equipment Location Diagram.....	2-32
Figure 2-30.	ASV System Configuration Diagram	2-33
Figure 2-31.	MLRS Equipment Location Diagram.....	2-34
Figure 2-32.	MLRS System Configuration Diagram	2-35
Figure 2-33.	BREACHER Equipment Location Diagram	2-36
Figure 2-34.	BREACHER System Configuration Diagram.....	2-37
Figure 2-35.	STRIKER Equipment Location Diagram	2-38
Figure 2-36.	STRIKER System Configuration Diagram.....	2-39
Figure 2-37.	FFCS Crew Station Address Switch	2-40
Figure 2-38.	RIT Radio Selection Switch	2-41
Figure 2-39.	Tripped vehicle master circuit breaker Flowchart	2-45
Figure 2-40.	MCS alphanumeric display Flowchart.....	2-46
Figure 2-41.	System power fault LED Flowchart.....	2-47
Figure 2-42.	ANR power fault LED Flowchart	2-48
Figure 2-43.	Radio can be keyed from an FFCS when MCS SYSTEM switch is in LS mode Flowchart	2-49
Figure 2-44.	No communication capability on a radio at more than 1 FFCS but communication over intercom is still possible Flowchart	2-50
Figure 2-45.	Radio does not key from a specific FFCS, but communication over intercom is still possible Flowchart.....	2-51
Figure 2-46.	Unable to communicate on intercom and radio from any 1 MOS or FFCS Flowchart	2-52
Figure 2-47.	Intercom always keyed Flowchart.....	2-53
Figure 2-48.	Field lines not heard on intercom Flowchart.....	2-54

LIST OF ILLUSTRATIONS (continued)

Figure	Title	Page
Figure 2-49.	Vehicle alarms not heard on intercom Flowchart.....	2-55
Figure 2-50.	No loudspeaker monitoring when LOUDSPEAKER switch is set to INT or RADIO Flowchart	2-56
Figure 2-51.	Headset fault Flowchart.....	2-57
Figure 2-52.	Ring Unconnected Flowchart.....	2-61
Figure 2-53.	Multiple Unconnected FFCSs/RITs Flowchart.....	2-62
Figure 2-54.	SINGLE “Xu” or Both-RIT-Channels Message For Two-Branch Configuration Flowchart	2-64
Figure 2-55.	Multiple “Xu” Messages for Two-Branch Configuration Flowchart.....	2-65
Figure 3-1.	Master Control Station (MCS).....	3-2
Figure 3-2.	Full Function Crew Station (FFCS)	3-3
Figure 3-3.	Monitor Only (Crew) Station (MOS)	3-4
Figure 3-4.	Radio Interface Terminal (RIT)	3-5
Figure 3-5.	Loudspeaker (LS).....	3-5
Figure 3-6.	MCS Mounting Hardware Sequences	3-8
Figure 3-7.	FFCS Mounting Hardware Sequences.....	3-9
Figure 3-8.	MOS Mounting Hardware Sequences.....	3-10
Figure 3-9.	RIT Mounting Hardware Sequences	3-11
Figure 3-10.	CVC Headset	3-12
Figure 3-11.	Liner and Earcups Assembly	3-13
Figure 3-12.	Earcushion and Front Foam Assembly	3-14
Figure 3-13.	Microphone, Boom, and Cable Assembly	3-15
Figure 3-14.	Boom Assembly and Mounting Hardware	3-16
Figure 3-15.	Helmet Liner Inserts	3-17
Figure 3-16.	Switch Cover(s).....	3-18
Figure 3-17.	Battery and Battery Cover	3-19
Figure 3-18.	CAPS and ACAPS Headsets Major Components	3-20
Figure 3-19.	Earcushion, Damp Cover and Foam Damper.....	3-21
Figure 3-20.	Overhelmet Strap Assembly	3-22
Figure 3-21.	Neckband (Spring Assembly) Cover	3-23
Figure 3-22.	Neckband (Spring Assembly)	3-24
Figure 3-23.	M-172 Microphone and Boom Assembly	3-25
Figure 3-24.	M-173 Microphone and Boom Assembly	3-25
Figure 3-25.	Microphone Boom Assembly Removal and Replacement (ACAPS Type B and CAPS Type II)	3-27
Figure 3-26.	Socket Blanking Plug (CAPS Type 1)	3-28
Figure 3-27.	Command and Control Headset	3-29
Figure 3-28.	VIS LRU(s) Knob.....	3-31
Figure 3-29.	Loudspeaker Assembly	3-32

LIST OF TABLES

Figure	Title	Page
Table 1-1.	Model Number and Installed Vehicle Platform Names.....	1-3
Table 1-2.	VIS Technical Data.....	1-5
Table 2-1.	Equipment Location and System Configuration Diagrams.....	2-3
Table 2-2.	System Troubleshooting Chart	2-42
Table 2-3.	Headset Inspection.....	2-58
Table 2-4.	MCS Alphanumeric Error Messages, Ring Configuration	2-60
Table 2-5.	MCS Alphanumeric Error Messages, Two-Branch Configuration.....	2-63
Table 3-1.	MCS Mounting Hardware (Figure 3-6)	3-6
Table 3-2.	FFCS Mounting Hardware (Figure 3-7).....	3-7
Table 3-3.	MOS Mounting Hardware (Figure 3-8).....	3-7
Table 3-4.	RIT Mounting Hardware (Figure 3-9)	3-7

HOW TO USE THIS MANUAL

LOCATING INFORMATION

TABLE OF CONTENTS. Refer to the Table of Contents to find out where information can be found. The Table of Contents lists each chapter title and section heading.

GLOSSARY. Refer to the glossary in Appendix G in the back of this manual to find the meaning of an unfamiliar term.

ABBREVIATIONS. Refer to the list of abbreviations in Appendix G in the back of this manual to find the term associated with an unfamiliar abbreviation.

NOMENCLATURE CROSS-REFERENCE LIST. Refer to Tables 1-1 and 1-2 to find common names and official nomenclature.

OPERATIONAL NOTES

WARNING PAGES are at the beginning of this manual. You should learn the warnings before doing maintenance on the equipment. Always follow appropriate safety procedures and precautions.

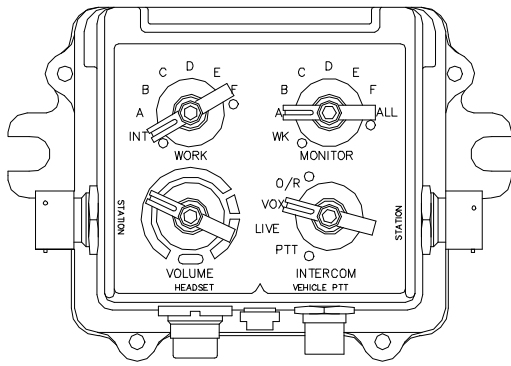

FULL FUNCTION CREW STATION

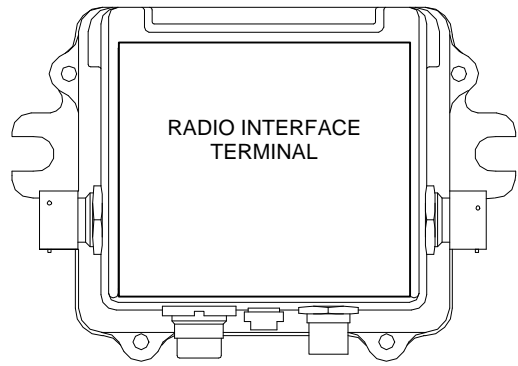

RADIO INTERFACE TERMINAL

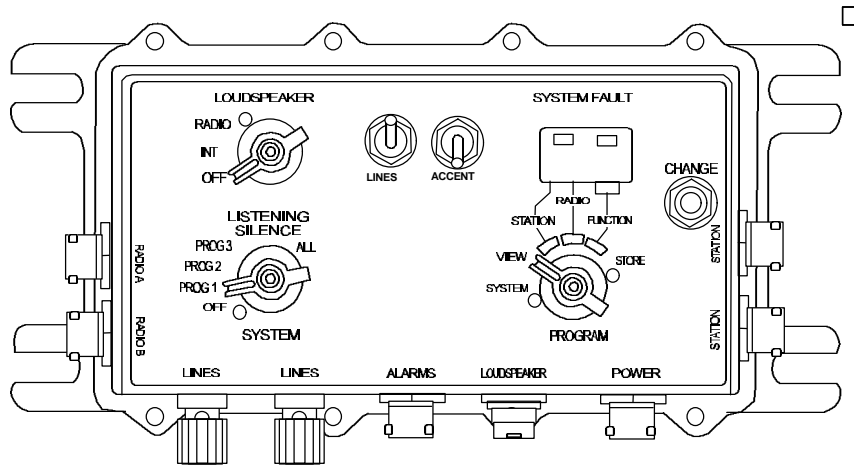

MASTER CONTROL STATION

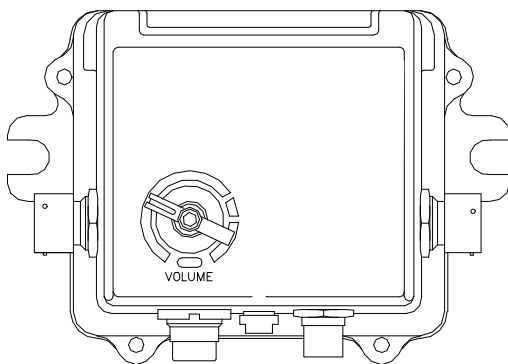

MONITOR ONLY STATION

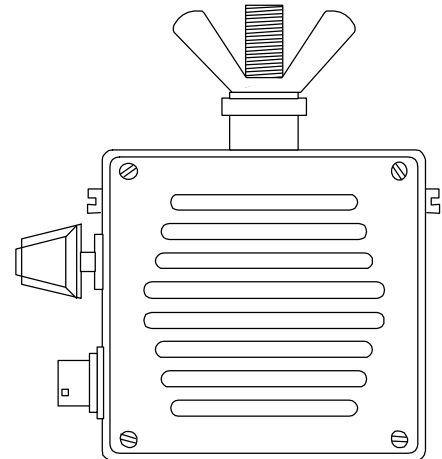

LOUDSPEAKER

Figure 1-1. AN/VIC-3(V) Line Replaceable Units

CHAPTER 1 INTRODUCTION

SECTION I General Information	1-1
SECTION II Equipment Description and Data	1-4
SECTION III Principles of Operation.....	1-7

SECTION I GENERAL INFORMATION

1.1. SCOPE

This technical manual contains instructions for troubleshooting and corrective maintenance for the AN/VIC-3, Vehicular Intercommunication Set, commonly known as the Vehicular Intercommunication Set (VIS), as well as a "Repair Parts and Special Tools List" Appendix listing the parts required to maintain the equipment.

- a. Type of manual: Unit Maintenance Manual (Including Repair Parts and Special Tools List).
- b. Model Number and Equipment Name: The official nomenclature is the AN/VIC-3(V) Intercommunication Set, Vehicular, with its common name being the Vehicular Intercommunication Set (VIS). There are many current and future variations of this system designed for specific vehicles and/or platforms, each with its own unique technical bulletin for installation. Refer to Table 1 -1 (at the end of this section) for the VIS version, vehicle /platform it's installed in, and the corresponding installation technical bulletin. These vehicle/platform specific variations have meaning only to the installation team as the system loses its identity when installed. Any vehicle/platform that has this system installed is referred to as having the VIS or "VIC-3"(AN/VIC-3(V)).
- c. Purpose of Equipment: The AN/VIC-3(V) is an intercommunication and radio-control system designed for ground mobile combat vehicles. Digital audio enhances speech quality and intelligibility. Headsets that incorporate active noise reduction (ANR) circuitry increase the effectiveness of vehicle communications. They offer increased hearing protection in the noisy environment of combat vehicles.
- d. Equipment Components. The AN/VIC-3(V) or VIS is a variety of installation kits designed for specific vehicles and/or platforms. The VIS is designed to replace the AN/VIC-1, in some cases utilizing the existing mounting hardware and brackets used by the AN/VIC-1. Kits consist of the following components, the type and quantity of which vary depending upon the specific vehicle and/or platform: Line Replaceable Units (LRUs (Boxes)) (Figure 1-1); cables (highway, power, alarm, etc.); headsets; brackets; and mounting hardware for securing LRUs and brackets. The RPSTL (Appendix C) of this manual only identifies the mounting hardware that is removed and replaced as part of the maintenance procedures associated with the VIS. If the bracket, and/or mounting hardware used to secure it, need replacing, refer to the appropriate installation technical bulletin, Table 1-1, to identify the correct Part Number (PN) / National Stock Number (NSN).

1.2. MAINTENANCE FORMS, RECORDS, AND REPORTS

- a. Reports of Maintenance and Unsatisfactory Equipment. Department of the Army forms and procedures used for equipment maintenance will be those prescribed by DA Pam 738-750, as contained in Maintenance Management Update.
- b. Reporting of Item and Packaging Deficiencies. Fill out and forward SF364 (Report of Discrepancy (ROD)) as prescribed in AR 735-11-2/DLAR 4140.55/SECNAVINST 4355.18/AFR 400-54/MCO 4430.3J.
- c. Transportation Discrepancy Report (TDR) (SF361). Fill out and forward Transportation Discrepancy Report (TDR) (SF361) as prescribed in AR 55-38/NAVSUPINST 4610.33C/AFR 75-18/MCO P4610.19D/DLAR 4500.15.

1.3. REPORTING EQUIPMENT IMPROVEMENT RECOMMENDATIONS (EIR)

If your AN/VIC-3 (V) Intercommunication set needs improvement, let us know. Send us an EIR. You, the user, are the only one who can tell us what you don't like about the equipment. Let us know why you don't like the design or performance. Put it on an SF 368 (Product Quality Deficiency Report). Mail it to: Commander, US Army Communications-Electronics Command and Fort Monmouth, ATTN: AMSEL-LC-LEO-D-CS-CFO, Fort Monmouth, NJ 07703-5000. We'll send you a reply.

1.4. CORROSION PREVENTION AND CONTROL

Corrosion Prevention and Control (CPC) of Army materiel is a continuing concern. It is important that any corrosion problems with this item be reported so that the problems can be corrected and improvements can be made to prevent the problem in the future.

While corrosion is typically associated with rusting of metals, it can also include deterioration of other materials, such as rubber and plastic. Unusual cracking, softening, swelling, or breaking of these materials may be a corrosion problem.

If a corrosion problem is identified, it can be reported using SF 368, Product Quality Deficiency Report. Use of key words such as "corrosion", "rust", "deterioration", or "cracking" will ensure that the information is identified as a CPC problem.

The form should be submitted to the address specified in DA PAM 738-750, Functional User's Manual for the Maintenance Management System (TAMMS).

1.5. DESTRUCTION OF ARMY ELECTRONICS MATERIEL

Destruction of Army electronics materiel to prevent enemy use shall be in accordance with TM 750-244-2 and AR 380-5.

1.6. ADMINISTRATIVE STORAGE

Administrative storage of equipment issued to and used by Army activities will have preventive maintenance performed in accordance with TM 11 -5830-263-10, Chapter 3, Section 1, Preventive Maintenance Check and Services (PMCS) charts before storing. When removing equipment from administrative storage, assure its operational readiness by performing PMCS. Disassembly and repacking of equipment for shipment or limited storage is covered in the procedures for the vehicle.

1.7. PREPARATION FOR STORAGE OR SHIPMENT

Refer to the appropriate paragraph in Chapter 3 for packaging instructions for Storage and Shipment.

Table 1-1. Model Number and Installed Vehicle Platform Names

NOTE

The Official Nomenclature, in the table below, requires the version number " * " for each of the vehicles as identified.

OFFICIAL NOMENCLATURE: AN/VIC-3(V) "*" " INTERCOMMUNICATION SET, VEHICULAR	VEHICLE/PLATFORM INSTALLED IN	INSTALLATION TECHNICAL BULLETIN
AN/VIC-3(V)1	M1A1 ABRAMS	TB 11-5830-263-20-1
AN/VIC-3(V)2	M1A2 ABRAMS	TB 11-5830-263-20-2
AN/VIC-3(V)3	M2A2 BRADLEY FIGHTING VEHICLE	TB 11-5830-263-20-3
AN/VIC-3(V)4	M3A2 BRADLEY FIGHTING VEHICLE	TB 11-5830-263-20-4
AN/VIC-3(V)5	M577 COMMAND POST	TB 11-5830-263-20-5
AN/VIC-3(V)6	M109A6 PALADIN	TB 11 -5830-263-20-6
AN/VIC-3(V)7	M1068 SICPS TRACKED VEHICLE	TB 11 -5830-263-20-7
AN/VIC-3(V)8	S-787 SICPS RIGID WALL SHELTER VEHICLE	TB 11 -5830-263-20-8
AN/VIC-3(V)9	M2A2 ODS BRADLEY FIGHTING VEHICLE	TB 11 -5830-263-20-9
AN/VIC-3(V)10	M3A2 ODS BRADLEY FIGHTING VEHICLE	TB 11-5830-263-20-10
AN/VIC-3(V)11	HEAVY ASSAULT BRIDGE (HAB)	TB 11-5830-263-20-11
AN/VIC-3(V)12	M992 FIELD ARTILLERY AMMUNITION SUPPORT VEHICLE (FAASV)	TB 11-5830-263-20-12
AN/VIC-3(V)13	M7 BRADLEY FIRE SUPPORT TEAM VEHICLE (BFIST)	TB 11-5830-263-20-13
AN/VIC-3(V)14	M88A2 RECOVERY VEHICLE	TB 11-5830-263-20-14
AN/VIC-3(V)15	ARMORED SECURITY VEHICLE (ASV)	TB 11-5830-263-20-15
AN/VIC-3(V)16	MULTIPLE LAUNCH ROCKET SYSTEM (MLRS)	TB 11-5830-263-20-16
AN/VIC-3(V)17	GRIZZLY (BREACHER)	TB 11-5830-263-20-17
AN/VIC-3(V)18	STRIKER	TB 11-5830-263-20-18

SECTION II EQUIPMENT DESCRIPTION AND DATA

1.8. EQUIPMENT CHARACTERISTICS, CAPABILITIES, AND FEATURES

REFER TO TM 11-5830-263-10, Operators Manual (Chapter 1).

1.9. LOCATION AND DESCRIPTION OF MAJOR COMPONENTS

REFER TO TM 11-5830-263-10, Operators Manual (Chapter 1).

1.10. DIFFERENCES BETWEEN MODELS

The AN/VIC-3(V) is an installation kit with multiple versions designed for specific vehicles and/or platforms. Table 1-1. "MODULE NUMBER AND INSTALLED VEHICLE /PLATFORM NAMES" in Section 1 of this chapter identifies the specific vehicle/platform that each version of the kit is installed in.

All kits contain one Master Control Station (MCS) and a minimum of two Full Function Crew Stations (FFCS). Some kit versions also contain Monitor Only Stations (MOS). The MCS has connections for 2 radios. For those vehicles/platforms that utilize more than two radios, a Radio Interface Terminal (RIT) is added to the kit. Each RIT allows two additional radios to be hooked up. The VIS can operate a maximum of six radios (1 MCS plus 2 RITs) at any one time.

Additionally, the installation kits contain various types (power, highway, alarm, etc.) and quantities of cables. Also supplied with the kits are various type of brackets and plates, along with the mounting hardware needed to secure them to the vehicle and/or platform. The Mounting hardware to secure the LRUs (Line Replaceable Units), (MCS, FFCS, etc.) to these brackets and plates is also included. In some vehicle/platform installations, existing brackets, plates and mounting hardware is utilized in conjunction with the hardware that is provided in the installation kits for the VIS.

1.11. EQUIPMENT DATA

Table 1-2 lists the electrical interfaces and physical dimensions of all the VIS components.

Table 1-2. VIS Technical Data

MCS Electrical Interfaces
INPUT VOLTAGE - 18-33 Vdc OUTPUT TO SYSTEM - 2.6 Amps. Protected by electronic circuit breaker OUTPUT TO ANR - 2.6 Amps. Protected by electronic circuit breaker
CREW STATION (BUS) INTERFACE - Nominal Impedance: 80 ohms CODING - Biphase Mark BIT RATE - 2.56 Mbps VOLTAGE LEVEL - 10 Vpk-pk (max), 2 Vpk-pk (min)
FIELD WIRE INTERFACE . Transformer Isolated, MCS to MCS compatible, MCS to AN/VIC 1780 compatible, and MCS to TA312 Phone compatible INPUT - Transformer Isolated Input INPUT LEVEL - Up to 90 volts OUTPUT LEVEL - 440 mVrms FREQUENCY RESPONSE - Nominally 300 Hz to 4.2 kHz
LOUDSPEAKER INTERFACE - Compatible with VIS loudspeaker OUTPUT IMPEDANCE - 1.6 ohms at 1 kHz $\pm 10\%$ OUTPUT LEVEL - 8 Vpk-pk MINIMUM LOAD IMPEDANCE - 4 ohms FREQUENCY RESPONSE - .300 Hz to 4.2 kHz
VEHICLE ALARM INTERFACE NUMBER OF INPUTS – 3 INPUT LEVELS - 150 mVrms, 45 mVrms, and 25 mVrms FREQUENCY RESPONSE - 300 Hz to 4.2 kHz
RADIO INTERFACES - SINCGARS-V, AN/GRC-213, AN/VRC-12 INPUT - 150 ohms $\pm 10\%$, 220 mVrms OUTPUT - 820 ohms $\pm 10\%$, 1.4 Vrms FREQUENCY RESPONSE - 300 Hz to 4.2 kHz PTT OUTPUT - Open collector, closure to ground. 35 V max. 50 mA max
FFCS Electrical Interfaces
CREW STATION (BUS) INTERFACE - Nominal Impedance: 80 ohms CODING - Biphase Mark BIT RATE - 2.56 Mbps VOLTAGE LEVEL - 10 Vpk-pk (max), 2 Vpk-pk (min)
EXTERNAL PTT SWITCH - Accepts 3 PTT lines: 1 on the Audio Connector and 2 Vehicle PTT lines AUDIO CONNECTOR - Open circuit +5V, Closure to ground to source >2.5 mA, Source Impedance: 820 ohms REMOTE PTT CONNECTOR RADIO - Open circuit +5V, Closure to ground to source >2.5 mA, Source Impedance: 820 ohms REMOTE PTT CONNECTOR INTERCOM – Open circuit +5V, Closure to ground to source >2.5 mA, Source Impedance: 820 ohms HEADSET CONNECTOR - Compatible with CVC, CAPS, ACAPS, CCH Headsets, H250 and H350 Handsets, VIS loudspeaker, and LS-454 loudspeaker MIKE INPUT - 150 ohms $\pm 10\%$, Unbalanced HEADPHONE OUTPUT - 1.6 ohms at 1 kHz, 8 Vpk-pk PTT LINE - Open circuit +5V, Closure to ground to source >2.5 mA, Source Impedance: 820 ohms FREQUENCY RESPONSE -300 Hz to 4.2 kHz

Table 1-2. VIS Technical Data (continued)

MOS Electrical Interfaces				
HEADSET CONNECTOR -Compatible with CVC, CAPS, ACAPS, and CCH Headsets, VIS loudspeaker, and LS-454 loudspeaker				
SOURCE IMPEDANCE - 1.6 ohms at 1 kHz				
OUTPUT LEVEL - 8 Vpk-pk				
MINIMUM LOAD IMPEDANCE - 4 ohms				
FREQUENCY RESPONSE - 300 Hz to 4.2 kHz				
RIT Electrical Interfaces				
CREW STATION (BUS) INTERFACE - Nominal Impedance: 80 ohms				
CODING - Biphase Mark				
BIT RATE - 2.56 Mbps				
VOLTAGE LEVEL - 10 Vpk-pk (max), 2 Vpk-pk (min)				
Loudspeaker Interface				
HEADPHONE OUTPUT -Compatible with CVC, CAPS, ACAPS, and CCH Headsets, VIS loudspeaker, and LS-454 loudspeaker				
SOURCE IMPEDANCE - 1.6 ohms at 1 kHz				
OUTPUT LEVEL - 8 Vpk-pk				
MINIMUM LOAD IMPEDANCE - 4 ohms				
FREQUENCY RESPONSE - 300 Hz to 4.2 kHz				
RADIO INTERFACES - SINGARS-V, AN/GRC-213, AN/VRC-12				
INPUT - 150 ohms ±10%, 220 mVrms				
OUTPUT - 820 ohms ±10%, 1.4 Vrms				
FREQUENCY RESPONSE - 300 Hz to 4.2 kHz				
PTT OUTPUT - Open collector, closure to ground 35 V max. 50 mA max. (PTT (push-to-talk) for radio use only)				
PHYSICAL CHARACTERISTICS				
UNIT	HEIGHT (IN)	DEPTH (IN)	WIDTH (IN)	WEIGHT (LBS)
MCS	6.0	3.75	10.0	5.0
FFCS	4.5	3.5	4.75	1.9
RIT	4.5	3.5	4.75	2.1
MOS	4.5	3.5	4.75	1.4
LOUDSPEAKER	4.75	3.0	4.75	3.5

SECTION III PRINCIPLES OF OPERATION

1.12. GENERAL OVERVIEW OF SYSTEM OPERATION

Refer to TM 11-5830-263-10, Chapter 1, Section 1, paragraph 1.10 for general overview of system operation.

1.13. POWER DISTRIBUTION

Power enters the MCS through the power connector and an Electromagnetic Compatibility (EMC) filter, which also provides reverse polarity and transient-spike protection. From this point, the power supply circuitry is split into two individual supplies: (1) the VIS regulated dc power supply, and (2) the ANR isolated power supply. Both power supplies provide identical power conditioning circuitry. This conditioning circuit provides overvoltage, undervoltage, and overcurrent protection. In the case of over (40Vdc) or under (15Vdc) voltages occurring, the circuit shuts off power to the system until the voltage returns to within the system's operating range. If the circuitry senses excessive amps from its power supply, the overcurrent electronic circuit breaker for that power supply will trip, removing power. This is detected by an internal circuit within the MCS and indicated on the MCS's POWER FAULT LED (SYSTEM or ANR) display as being an overcurrent condition. To reset either circuit breaker, the SYSTEM switch on the MCS is turned to "off" then back to one of the "on" positions.

The regulated system power supply provides +5Vdc and -5Vdc for the MCS internal circuitry and supplies power to the other VIS modules via the highway cables.

The ANR power supply provides a +24Vdc regulated voltage that is connected into the system highway to power the ANR modules in the headsets.

The PTT switch on the headset, set in the momentary position for transmission over a selected radio, has a maximum input voltage and current of 35Vdc and 50 mA.

1.14. DATA TRANSMISSION

The system component parts function to allow integration of vehicle crew internal communications and radio communication in a ring bus configuration. The system communication scheme, Time Division Multiple Access (TDMA), is synchronized by the MCS. VIS appends 1 of 32 destination addresses to each byte of digital data. Of these 32 addresses, 16 have been allocated for up to 8 radios (1 for transmit and 1 for receive for each radio), 4 have been allocated for intercom, 1 for control, with 11 addresses remaining as spares for future system growth. (VIS currently uses a maximum of 6 radios.) The MCS regulates the timing of the digital packets of information, which may be initiated from any other station except the MOS. The MOS can receive audio information but cannot transmit. The distribution of audio (intercom) to the MOSs is achieved in an analog format; however, the audio power amplification is individually controlled at each MOS to prevent volume fluctuations when crewmembers connect or disconnect their headsets. This approach also isolates the headsets from the audio source, increasing the survivability of the system if a particular headset becomes damaged or short-circuited. The FFCS allows an operator full access to all radio and intercom communications and provides the operator with microphone keying options. Each RIT interfaces with two radios. When multiple RITs are connected to the ring bus, up to six radios can be interfaced. This includes the two radios interfaced to the MCS. The MCS and RIT convert analog radio signals from analog to digital and place the packets of information on the bus, which allows the commander and crew to select the digitized audio information in various combinations. They also convert FFCS audio from digital to analog for transmission over the radios. The FFCS then selects which packets of radio information it requires and converts the digitized audio to analog. The FFCS also communicates over the intercom to maintain internal communication between crewmembers and communicates to the MCS and RIT for external radio traffic.

Further, audio levels can be controlled to accent internal communication in emergency conditions. The system interfaces with a loudspeaker and various types of headsets (CVC, CAPS, ACAPS, and CCH); the loudspeaker connects to the MCS or to any FFCS/MOS and allows one-way communication to crew or troops either being transported or working in close proximity to the vehicle.

The system incorporates an Auto Reconnect Circuit (ARC) that continually monitors the system bus. If a break occurs in the ring bus, the ARC automatically restores system connectivity and informs the operator of the malfunction.

1.15. VIS CABLING

VIS is interconnected using a single type of cable called a highway cable. Data, power, and analog signals are carried by a seven-conductor cable, which incorporates internal and external shields as shown in figure 1-2. The external shielding prevents cross talk from external sources; the internal shielding prevents cross talk internal to the cable. This cable carries the VIS data bus on the inner shielded twisted-pair of conductors. Two conductors carry conditioned system power for distribution to all units, two conductors carry the conditioned Active Noise Reduction (ANR) power, and the seventh conductor carries the analog audio signal for the MOSs. The two shields are combined with the zero volts ground on the vehicle body. The power supply conductors and intercom audio are connected in a ring.

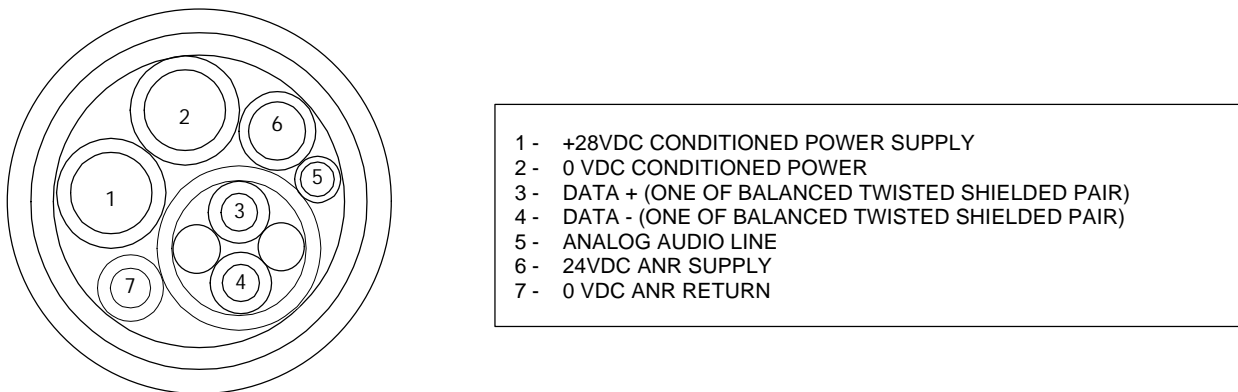

Figure 1-2. Highway Cable Construction

- a. **Partial Cable Failure** – The data bus conductors are not connected in a complete ring but as a bus which originates and terminates inside the MCS on the Automatic Reconnect Circuit (ARC). The ARC monitors data bus activity at the terminating end of the bus. In normal operation there will always be activity on the bus. If the ARC detects no bus activity (i.e., a break has occurred somewhere on the data bus) it instantly activates the re-route circuit, connecting the originating and terminating ends of the bus, thereby automatically reconnecting those units located "downstream" of the cable break. The ARC is so quick in reconnecting the bus that its operation normally goes unnoticed by the crew; therefore to alert the crew that a cable break has occurred, the CPM reports a "ring unconnected (ru)" fault on the MCS display.
- b. **Total Cable Failure** – If any single VIS cable is totally severed, the system will continue to operate without degradation in performance. The system reconfigures itself automatically (i.e., power is still available to each unit; the ARC detects the break and reconnects any unconnected units; a "ring unconnected (ru)" warning is displayed on the MCS by the CPM).

c. Partial Cable Severing –

- If any cable is partially severed, the system will continue to operate without any performance degradation.
- If either or both conditioned power conductors are severed, power is still available at each unit. With both data-bus conductors still intact, the ARC will not close.
- If either or both ground conductors are severed, ground returns are still available because of the ring architecture. Again, with both data conductors still intact, the ARC will not be triggered.
- If either or both data bus conductors are severed, the ARC will trigger, reconnecting any unconnected units instantly.
- If the ground shields are totally severed, the ground is carried around the ring in both directions by the cable and also through the vehicle body to each FFCS, MOS, and RIT. The loss of shielding is not significant and will not affect the operation of the system.

d. Partial Cable Severing with Shorted Conductors –

- If a cable is partially severed and the conductors are shorted together, the system cannot continue to operate normally. None of the units will be damaged internally, no matter which leads are shorted.
- Either data bus conductor may be shorted to either of the power conductors, either of the grounds, or the zero volts ground shield without affecting the VIS operation. The transformer coupling of the data bus to each unit prevents damage.
- If the data bus conductors are shorted together, or both to ground, or both to the same conditioned power conductors, the data bus cannot function. All communications will cease and the CPM software will cause the MCS to display in sequence that all units in the system have become unconnected (e.g., 1 u, 2u, 3u, 4u, Au, Bu.... ru), showing that the whole data bus has been stopped. As soon as the damaged cable is disconnected, all communications are restored.
- If the +28Vdc conditioned system power conductor is shorted to the zero volts ground, the MCS system power conditioning circuit overcurrent limit will trip at approximately two amps. The system is then effectively isolated from power and only a single LED on the MCS display will be illuminated. This would indicate that the overcurrent limit circuit has tripped. In this way the system isolates itself from further damage. The ANR power supply will remain intact, allowing ANR protection to remain operational. For immediate corrective action, the faulty cable section will be disconnected. Following disconnect, replacement or repair of the damaged cable, the trip circuit may be reset by switching the MCS SYSTEM switch to "off" and then back to one of the "on" positions, restoring full system operation.
- If the +24Vdc conditioned ANR power conductor is shorted to the zero volts ground, the MCS ANR power-conditioning circuitry will operate its overcurrent limit trip circuit. This circuit is set to trip at approximately two amps. ANR equipment will then cease to operate and the MCS CPM will indicate that the overcurrent limiter has tripped while the VIS system will continue to operate normally. Following replacement or repair of the damaged cable, the trip is reset by switching the MCS SYSTEM switch to "off" and then back to one of the "on" positions.

1.16. BATTLE DAMAGE DESCRIPTION

Battle damage control in the VIS is made possible by redundant paths in the highway - cable ring architecture. The system continues to function if there is a single break in any of the cables or the paths within the crew boxes that carry power, data signals, or analog audio. Special circuitry within the MCS and each of the FFCS and RIT boxes comes into play if the data signal path is broken. If the MCS does not sense receipt of the digital data stream at its bottom STATION connector, it recognizes that there is a break in the path and initiates transmission from the bottom connector to communicate with the disconnected portion of the ring. (This involves operation of an internal relay that removes a terminating resistor from the data path and inserts the same signal transmitted at the top station connector.)

The break in the data path is also sensed and accommodated by the digital boxes on either side of the break. (A dc bias on the two data lines forming the path segment interconnecting adjacent boxes activates a zener diode circuit that applies terminating resistors to prevent signal reflections from both sides of the break in the data path.) The system continues to provide communication to all crew stations, and "ru" is displayed by the MCS to indicate that maintenance is required. (The dc bias voltage of approximately 20 volts provides a convenient method to verify continuity to connectors within FFCSs and RITs during troubleshooting.)

CHAPTER 2

UNIT TROUBLESHOOTING PROCEDURES

SECTION I	General Unit Troubleshooting Inspection	2-1
SECTION II	Equipment Location and Configuration Diagrams	2-2
SECTION III	System Troubleshooting With No Error Shown on Alphanumeric Display	2-42
SECTION IV	System Troubleshooting With Error Shown on Alphanumeric Display	2-59
SECTION V	Troubleshooting of Cable Assemblies.....	2-66

SECTION I GENERAL UNIT TROUBLESHOOTING INSPECTION

CAUTION

BE SURE TO REMOVE POWER FROM THE MCS BEFORE DISCONNECTING OR REMOVING AND REPLACING COMPONENTS AND/OR CABLES.

2.1. GENERAL

If a troubleshooting procedure identifies a piece of equipment as defective refer to Chapter 3 of this manual for all Removal and Replacement Procedures. Section III of the Maintenance Allocation Chart (MAC) in Appendix B contains a list of all tools and test equipment required to troubleshoot the Vehicular Intercommunication Set (VIS). Appendix C contains the Repair Parts and Special Tools List (RPSTL) identifying the piece parts for repair.

2.2. SCOPE OF UNIT TROUBLESHOOTING

Unit maintenance involves confirmation of operational problems reported by VIS users, diagnosis of confirmed problems, and problem correction usually by replacement of units found to be faulty. Problems may be identified by physical inspection of damaged equipment, by specific failure indications such as an illuminated fault light or an inability to communicate, or by an alphanumeric error indication on the MCS display. To adequately troubleshoot VIS, the unit maintainer is required to have one spare MCS and one spare RIT (if vehicle has only one RIT normally).

2.3. EQUIPMENT INSPECTIONS/CHECKS/GUIDELINES

Prior to beginning any troubleshooting procedures always review the report of the user problems and verify if possible by observation. Sections IV, V, and VI of this chapter cover, respectively:

- Troubleshooting system problems that "do not" show up as errors on the alphanumeric display.
- Troubleshooting system problems that "do" show up as errors on the alphanumeric display.
- Troubleshooting cable assemblies.

Before initiating any of the troubleshooting procedures in Sections IV, V, and VI there are some checks that can be accomplished. These checks, as well as the troubleshooting procedures in later sections, involve utilizing the VIS Operator's Manual, TM 11-5830-263-10. The checks are as follows:

- a. Loudspeaker and/or Loudspeaker Cable Problems.
 1. Turn MCS off and disconnect Loudspeaker cable at MCS if connected.
 2. Turn MCS on. If problem has disappeared, turn MCS off and reconnect Loudspeaker cable.
 3. Turn MCS on. If problem reappears, turn MCS off and substitute with known good Loudspeaker and cable.
 4. Turn MCS on. If problem disappears, Loudspeaker and/or cable may be faulty. Refer to the troubleshooting procedures in Sections IV and VI.
 5. If problems reappear, MCS may be faulty. Refer to the troubleshooting procedures in Section IV.

- b. Do a system configuration (as explained in the Operator's manual). Verify what the MCS identifies as connected in the ring and that it corresponds to the vehicle placard located next to the MCS in the vehicle, or as shown on the Equipment Location Diagram for the specific vehicle in Section II of this chapter. If there is not a match with what the MCS identifies and what is on the vehicle placard then the following may have occurred:
 1. Cables may be disconnected, in which case they need to be physically inspected and reconnected.
 2. The FFCS or RIT have not been correctly set, in which case they need resetting. The procedures for setting the crewstation/radio switch for the FFCS/RIT can be found in Section III of this chapter.
 3. If cables are connected, and the FFCS and RIT are properly set and problems still exist in terms of the system configuration mode then refer to the troubleshooting procedures in Section IV.

- c. If the system is properly configured, place the SYSTEM switch on the program being utilized (PROG 1, 2, or 3), and the PROGRAM switch on VIEW. Observe the levels of radio access programmed into the MCS. If discrepancies are noted reprogram the MCS using the Operator's manual. If discrepancies still exist, or the MCS will not program, refer to the troubleshooting procedures in Section IV.

SECTION II EQUIPMENT LOCATION AND SYSTEM CONFIGURATION DIAGRAMS

2.4. GENERAL

As stated in the previous section problems with the VIS can occur in various forms. System problems may occur without showing up as error messages on the alphanumeric display, or system problems may occur that do show up as error messages on the alphanumeric display. Corrective action for the VIS involves principally the replacement of a single unit (box or cable), or, in the case of a headset, a component part. The procedures apply whether trouble is in radio or intercom communications. Damage to more than one VIS unit is beyond the scope of these procedures. In the event of suspected damage to multiple units, the general approach is to disconnect all units from the system, then add the units in sequence to the system one at a time for evaluation. Following this general approach isolates individual boxes, so that in effect, possible multiple faults are reduced to single faults that are troubleshot one at a time. Whenever troubleshooting the VIS extensive use should be made of the Operator's Manual, TM 11-5830-263-10. Procedures for correctly setting the FFCS and RIT can be found in Section III of this chapter.

2.5. TROUBLESHOOTING USING THE EQUIPMENT LOCATION AND CONFIGURATION DIAGRAMS

- a. From the System Configuration Diagram for your vehicle, determine whether units are connected by highway cables in a ring configuration (as most vehicles are) or are connected in a two-branch configuration.
- b. If your vehicle is connected in a ring configuration, refer to Table 2-4 for a listing of MCS alphanumeric error messages with their corrective measures. If your vehicle is connected in a two-branch configuration refer to Table 2-5 for a listing of MCS alphanumeric error messages with their corrective measures
- c. After performing each corrective measure, power the MCS off then back on and check for normal operating indications on the equipment. Use a Multimeter, the specific type and model of which can be found in Section III of the Maintenance Allocation Chart, to measure vehicle battery voltage and to check cable continuity. Cable troubleshooting is covered in Section VI.

The Equipment Location Diagrams and the System Configuration Diagrams for the vehicles shown in Table 2-1 are included on facing pages:

Table 2-1. Equipment Location and System Configuration Diagrams

VEHICLE TYPE	EQUIPMENT LOCATION		SYSTEM CONFIGURATION	
	FIGURE	PAGE	FIGURE	PAGE
M1A1 ABRAMS	Figure 2-1	Page 2-4	Figure 2-2	Page 2-5
M1A2 ABRAMS	Figure 2-3	Page 2-6	Figure 2-4	Page 2-7
M2A2 BRADLEY FIGHTING VEHICLE	Figure 2-5	Page 2-8	Figure 2-6	Page 2-9
M3A2 BRADLEY FIGHTING VEHICLE	Figure 2-7	Page 2-10	Figure 2-8	Page 2-11
M577 COMMAND POST	Figure 2-9	Page 2-12	Figure 2-10	Page 2-13
M109A6 PALADIN	Figure 2-11	Page 2-14	Figure 2-12	Page 2-15
M1068 SICPS TRACKED VEHICLE	Figure 2-13	Page 2-16	Figure 2-14	Page 2-17
S787 SICPS RIGID WALL SHELTER VEHICLE	Figure 2-15	Page 2-18	Figure 2-16	Page 2-19
M2A2 ODS BRADLEY FIGHTING VEHICLE	Figure 2-17	Page 2-20	Figure 2-18	Page 2-21
M3A2 ODS BRADLEY FIGHTING VEHICLE	Figure 2-19	Page 2-22	Figure 2-20	Page 2-23
HAB	Figure 2-21	Page 2-24	Figure 2-22	Page 2-25
M992 FAASV	Figure 2-23	Page 2-26	Figure 2-24	Page 2-27
M7 BFIST	Figure 2-25	Page 2-28	Figure 2-26	Page 2-29
M88A2 RECOVERY VEHICLE	Figure 2-27	Page 2-30	Figure 2-28	Page 2-31
ARMORED SECURITY VEHICLE (ASV)	Figure 2-29	Page 2-32	Figure 2-30	Page 2-33
MULTIPLE LAUNCH ROCKET SYSTEM (MLRS)	Figure 2-31	Page 2-34	Figure 2-32	Page 2-35
GRIZZLY (BREACHER)	Figure 2-33	Page 2-36	Figure 2-34	Page 2-37
STRIKER	Figure 2-35	Page 2-38	Figure 2-36	Page 2-39

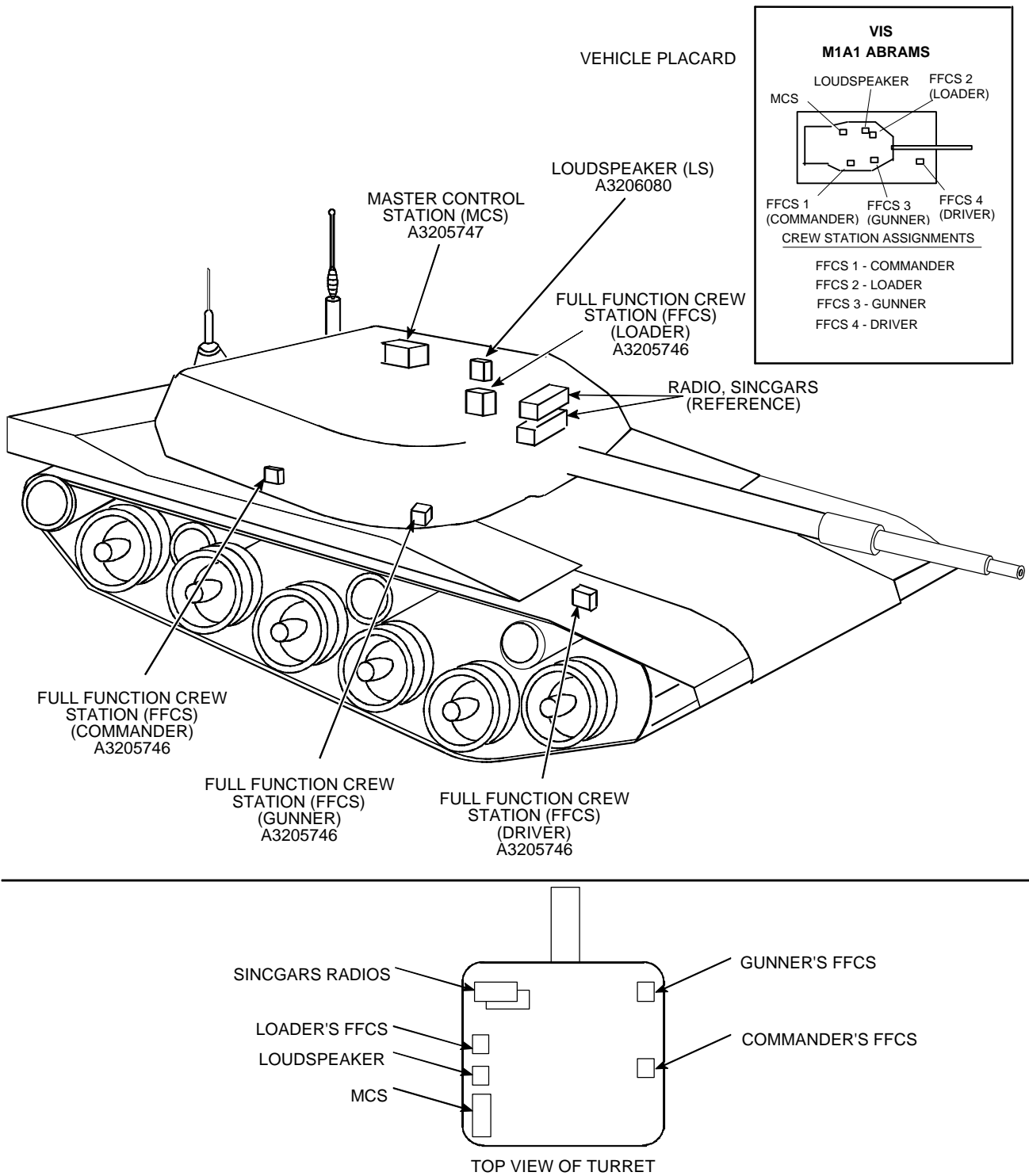
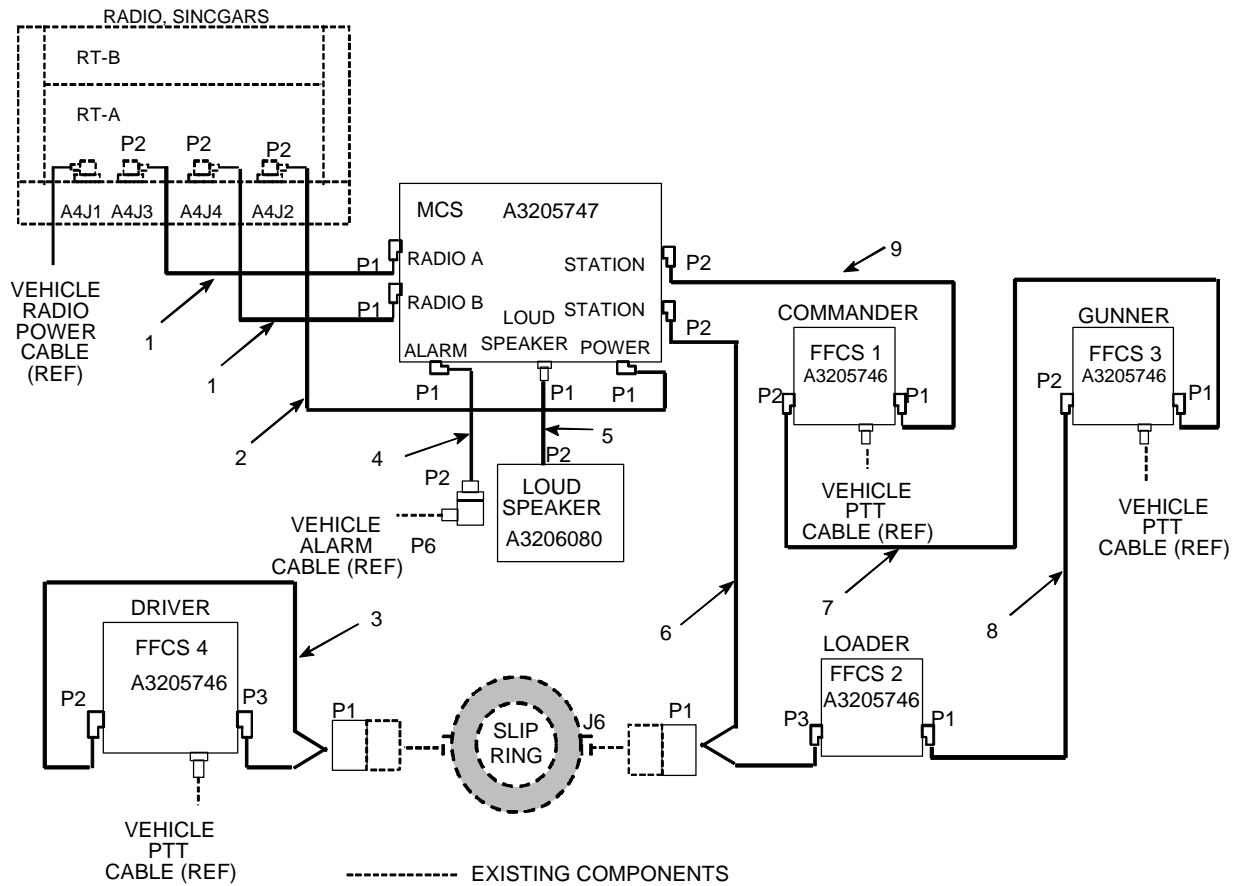

Figure 2-1. M1A1 ABRAMS Equipment Location Diagram



CABLE RING SEQUENCE FOR M1A1 VEHICLE

FROM VIS BOX	CABLE	TO VIS BOX	CABLE
MCS (TOP CONN)	#9 (P2)	FFCS 1	#9 (P1)
FFCS 1	#7 (P2)	FFCS 3	#7 (P1)
FFCS 3	#8 (P2)	FFCS 2	#8 (P1)
FFCS 2	#6 (P3)	THRU SLIP RING ASSY TO FFCS 4	#3 (P3)
FFCS 4	#3 (P2)	THRU SLIP RING ASSY TO MCS (BOT. CONN)	#6 (P2)

CABLE PART NUMBERS FOR M1A1 VEHICLE

1. A3206019-9 (RECEIVE/TRANSMIT)
2. A3206017-7 (POWER)
3. A3206102-4-4 (HIGHWAY/VEHICLE)
4. A3206021-19 (ALARM)
5. A3206193-6 (LOUDSPEAKER)
OR
A3206193-30 (LOUDSPEAKER)
6. A3206081-3-3 (HIGHWAY/VEHICLE)
7. A3206018-8 (HIGHWAY)
8. A3206018-20 (HIGHWAY)
9. A3206018-21 (HIGHWAY)
10. A3206020 (BAILOUT) CONNECTED TO FFCS AND HEADSET NOT SHOWN

Figure 2-2. M1A1 ABRAMS System Configuration Diagram

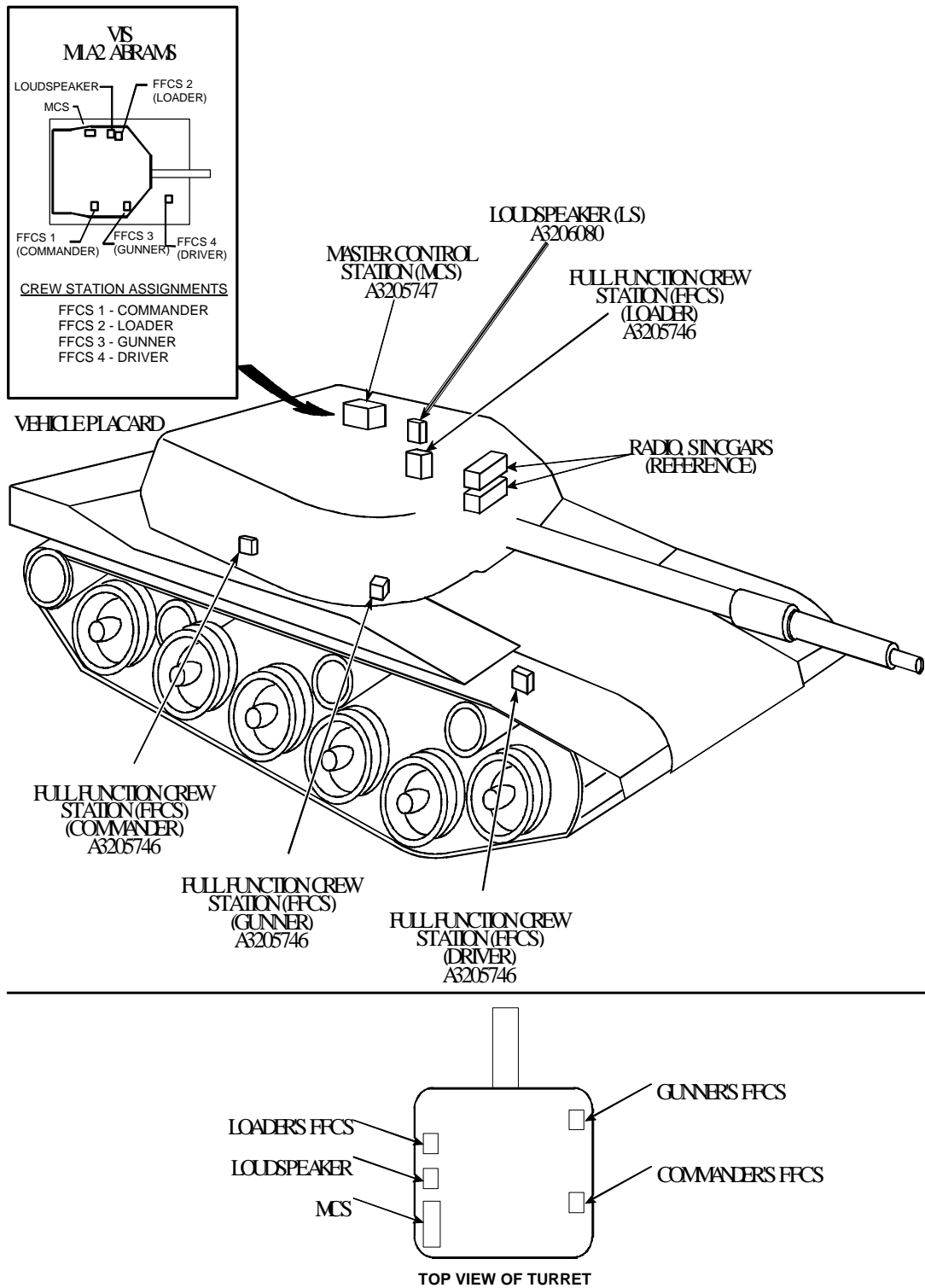
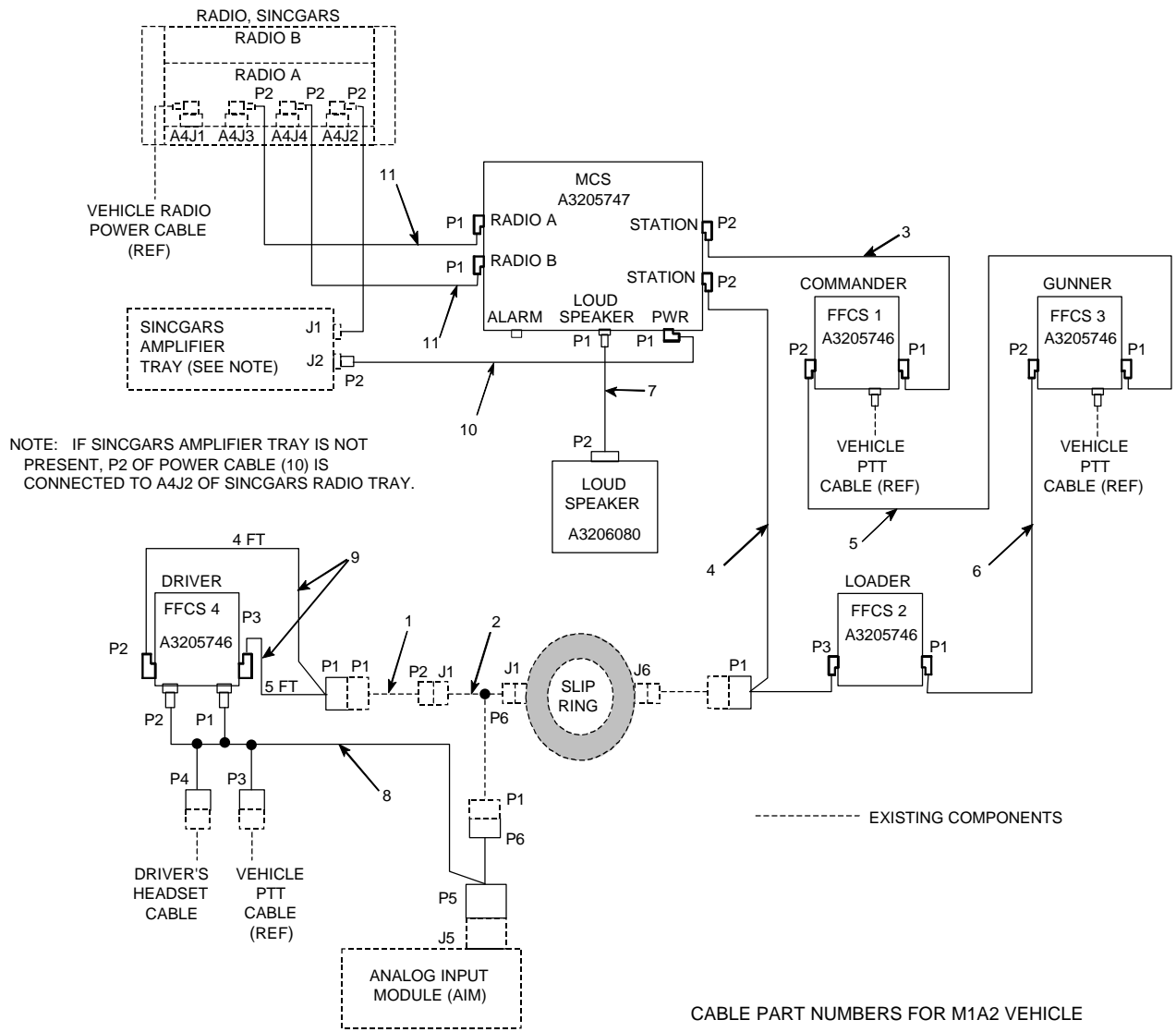

Figure 2-3. M1A2 ABRAMS Equipment Location Diagram



CABLE PART NUMBERS FOR M1A2 VEHICLE

- 1. 2W110-1 (REFERENCE)
- 2. 2W110-8 (REFERENCE)
- 3. A3206018-21 (HIGHWAY)
- 4. A3206120-3-3 (HIGHWAY/VEHICLE)
- 5. A3206018-8 (HIGHWAY)
- 6. A3206018-20 (HIGHWAY)
- 7. A3206193-6 or -30 (LOUDSPEAKER)
- 8. A3206118 (ALARM)
- 9. A3206121-4-5 (HIGHWAY/VEHICLE)
- 10. A3206017-7 (POWER)
- 11. A3206019-9 (RECEIVE/TRANSMIT)
- 12. A3206020 (BAILOUT, Connected to FFCS and Headset, not shown in diagram)

RING SEQUENCE FOR M1A2 VEHICLE

FROM VIS BOX	CABLE	TO VIS BOX	CABLE
MCS (TOP CONN)	#3 (P2)	FFCS 1	#3 (P1)
FFCS 1	#5 (P2)	FFCS 3	#5 (P1)
FFCS 3	#6 (P2)	FFCS 2	#6 (P1)
FFCS 2	#4 (P3)	THROUGH SLIP RING ASSY TO FFCS 4	#9 (P3)
FFCS 4	#9 (P2)	THROUGH SLIP RING ASSY TO MCS (BOT.CONN)	#4 (P2)

Figure 2-4. M1A2 ABRAMS System Configuration Diagram

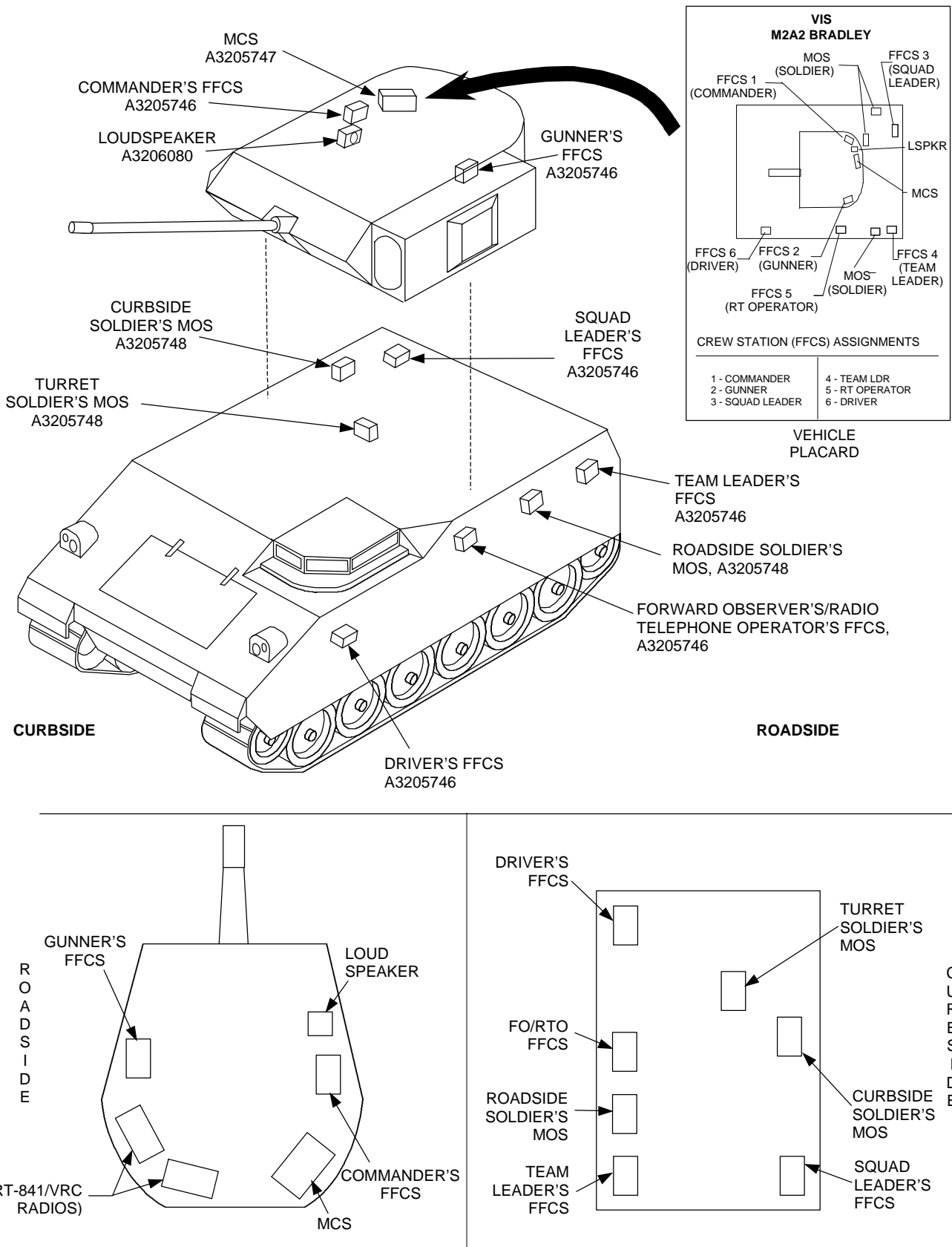

Figure 2-5. M2A2 BRADLEY Equipment Location Diagram

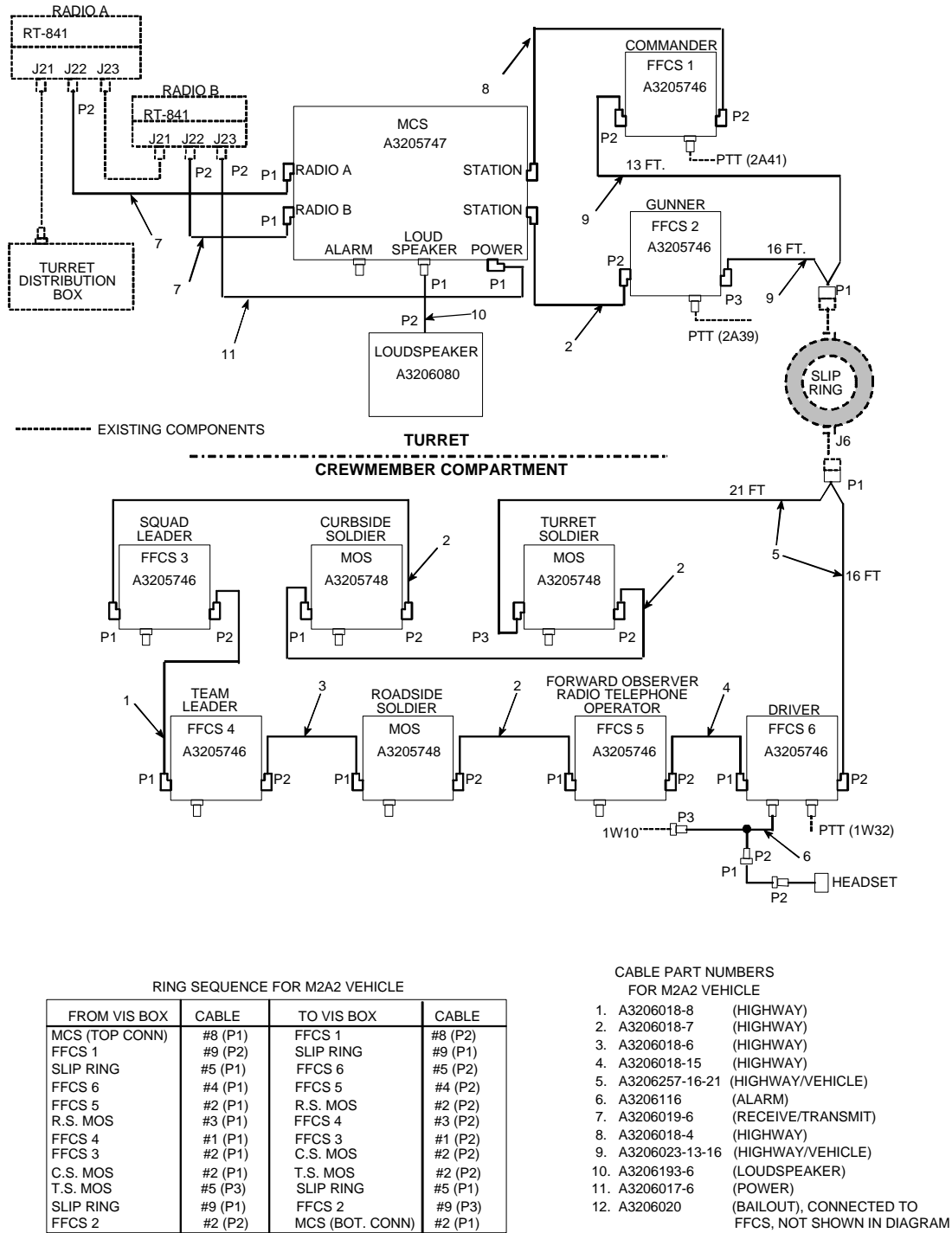

Figure 2-6. M2A2 BRADLEY System Configuration Diagram

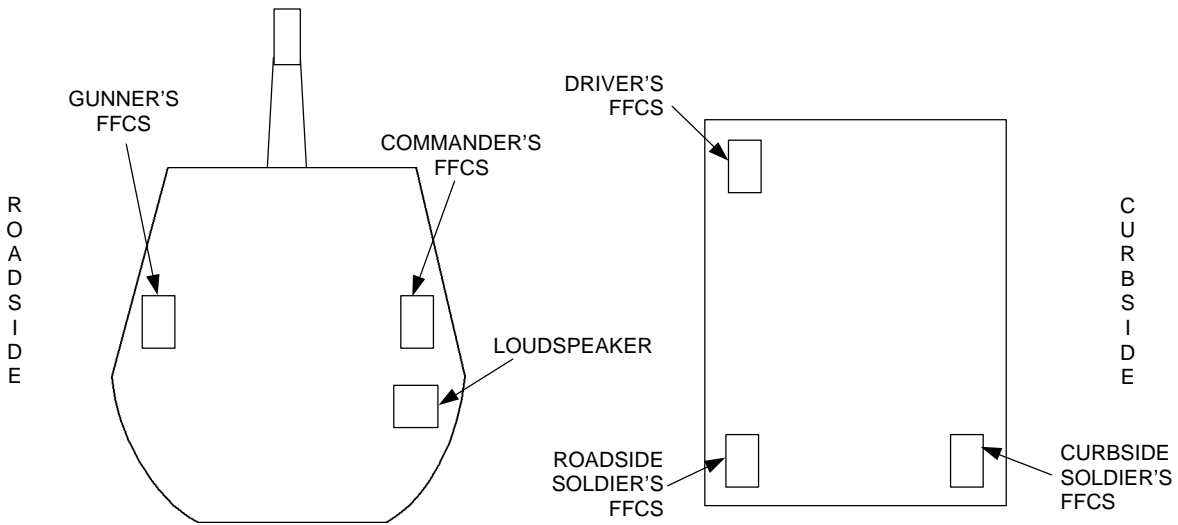
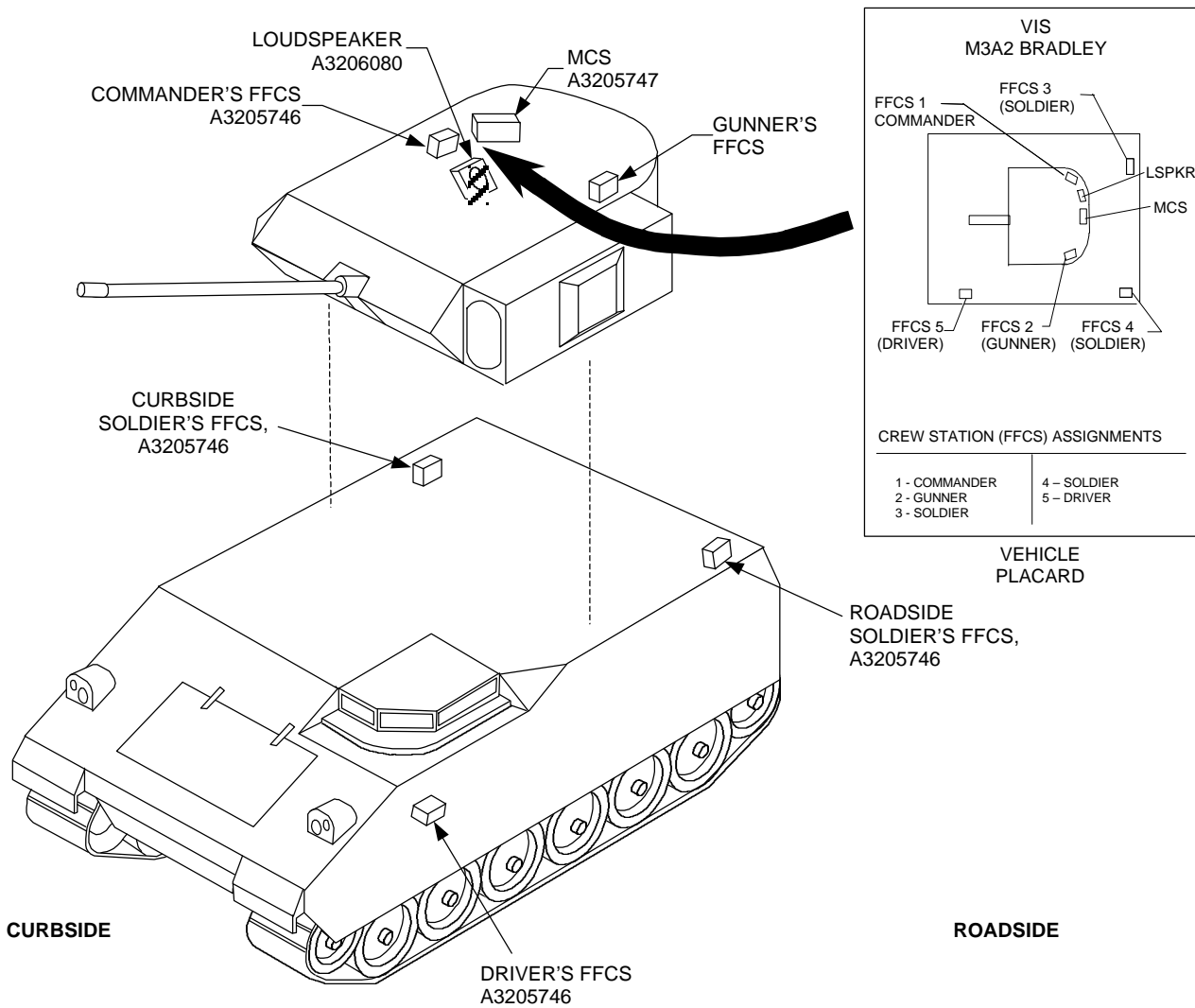

Figure 2-7. M3A2 BRADLEY Equipment Location Diagram

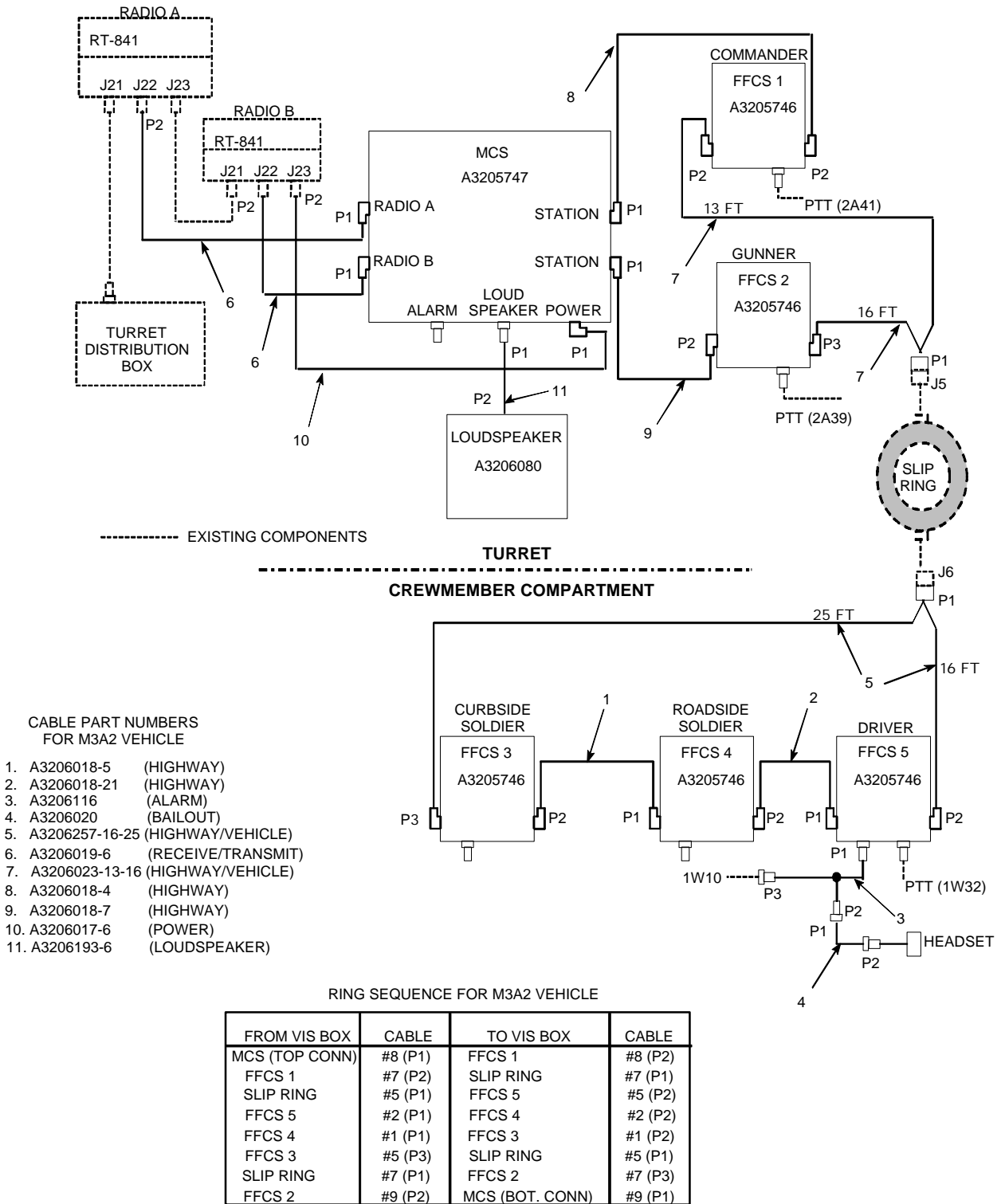

Figure 2-8. M3A2 BRADLEY System Configuration Diagram

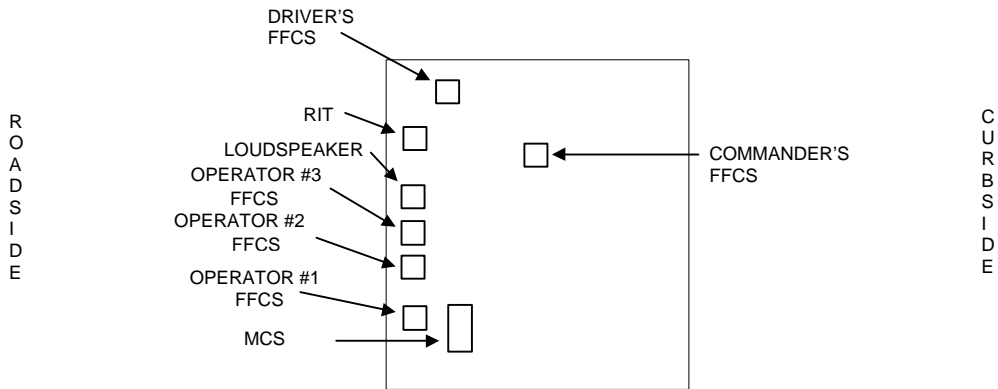
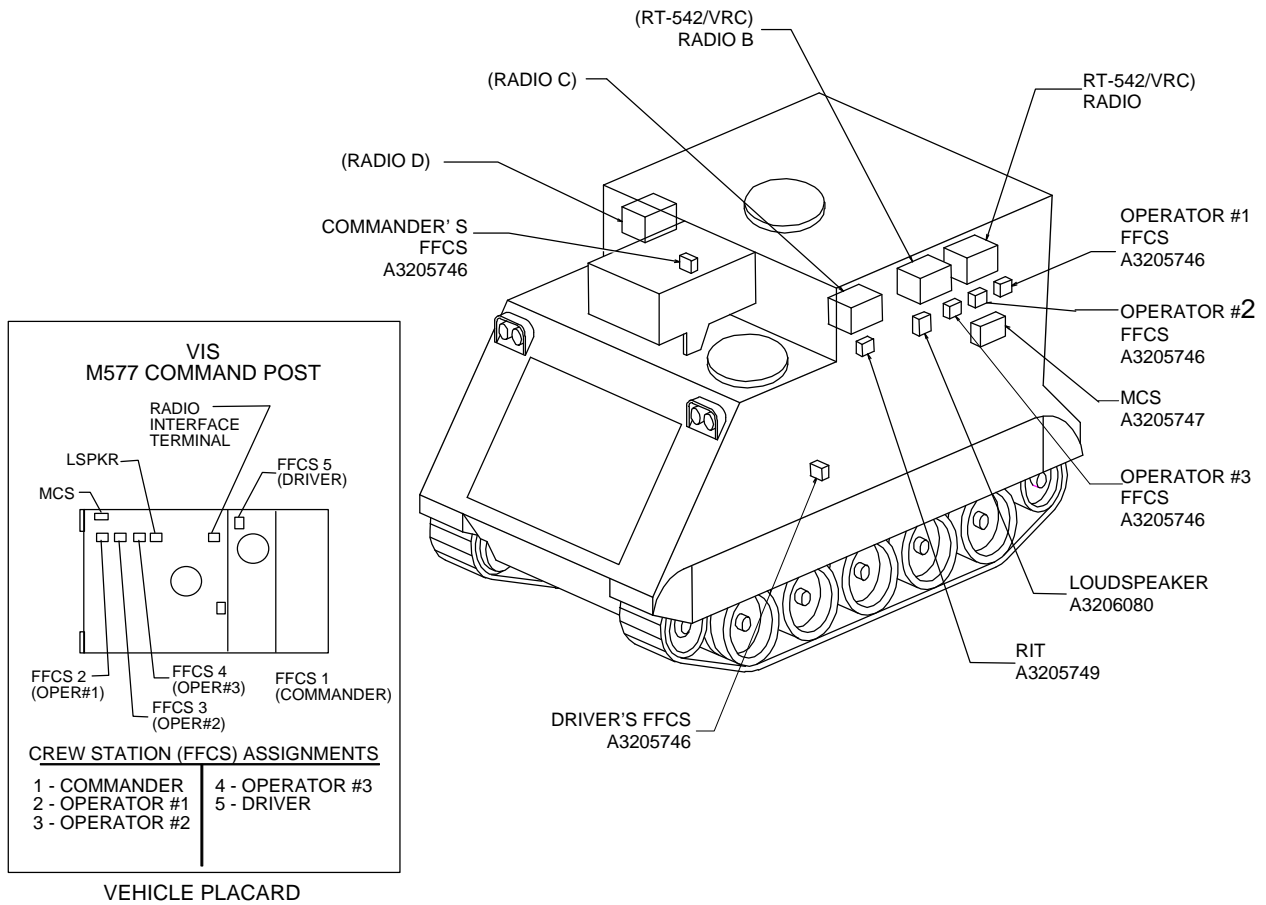
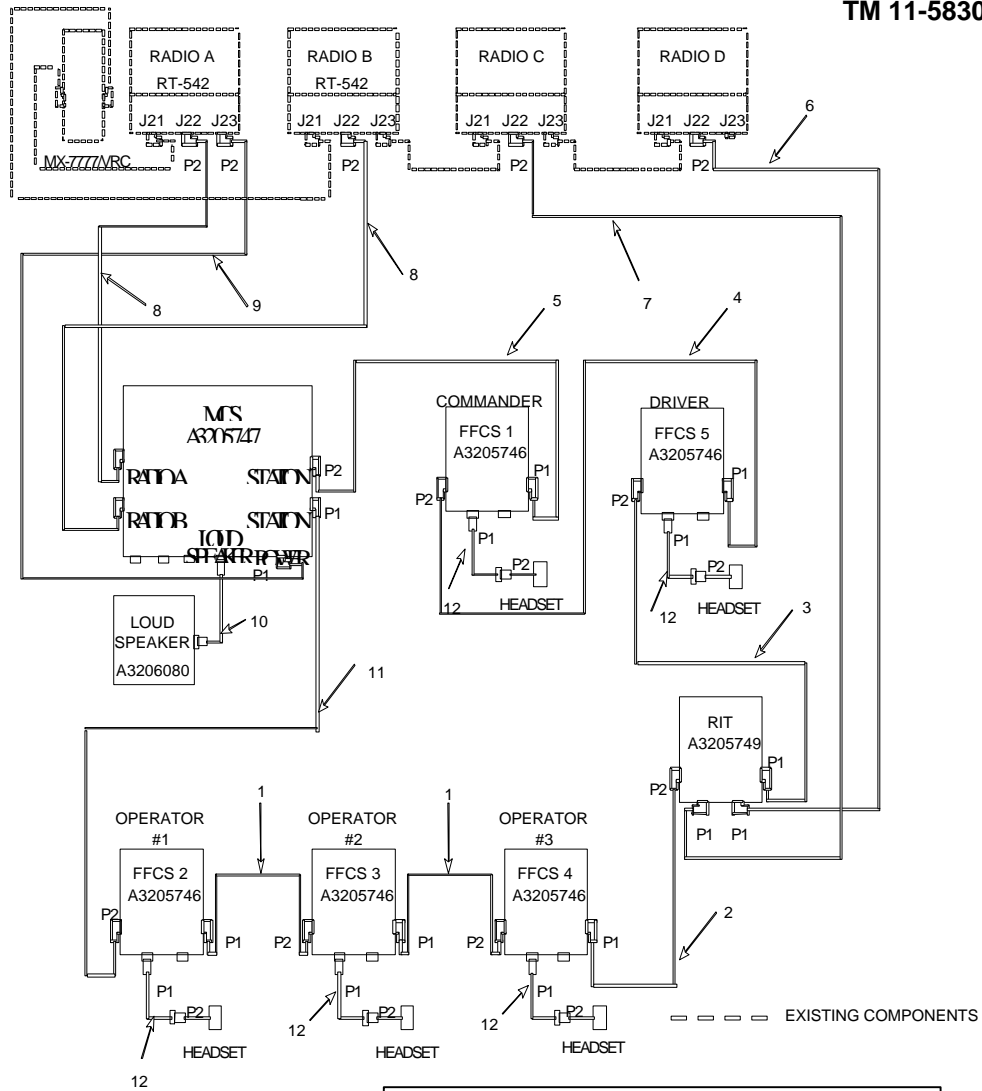

Figure 2-9. M577 Equipment Location Diagram



CABLE PART NUMBERS FOR M577 VEHICLE

- 1. A3206018-2 (HIGHWAY)
- 2. A3206018-12 (HIGHWAY)
- 3. A3206018-7 (HIGHWAY)
- 4. A3206018-16 (HIGHWAY)
- 5. A3206018-19 (HIGHWAY)
- 6. A3206019-12 (RECEIVE/TRANSMIT)
- 7. A3206127-6 (RECEIVE/TRANSMIT)
- 8. A3206019-6 (RECEIVE/TRANSMIT)
- 9. A3206017-5 (POWER)
- 10. A3206193-6 or -30 (LOUDSPEAKER)
- 11. A3206018-6 (HIGHWAY)
- 12. A3206020 (BAILOUT)

NOTE: For SINCGARS Installations
Radio and Power cables are as shown below

Cable	P1 Connection	P2 Connection
8	MCS, RADIO A	RADIO A/B, A4J3
8	MCS, RADIO B	RADIO A/B, A4J4
9	MCS, POWER	RADIO A/B, A4J1
7	RIT C/E	RADIO CD, A4J3
6	RIT D/F	RADIO CD, A4J4
	Existing RADIO A/B, A4J2	RADIO CD, A4J1

RING SEQUENCE FOR M577 VEHICLE

FROM VIS BOX	CABLE	TO VIS BOX	CABLE
MCS (TOP CONN)	#5 (P2)	FFCS 1	#5 (P1)
FFCS 1	#4 (P2)	FFCS 5	#4 (P1)
FFCS 5	#3 (P2)	RIT	#3 (P1)
RIT	#2 (P2)	FFCS 4	#2 (P1)
FFCS 4	#1 (P2)	FFCS 3	#1 (P1)
FFCS 3	#1 (P2)	FFCS 2	#1 (P1)
FFCS 2	#11 (P2)	MCS (BOT CONN)	#11 (P1)

Figure 2-10. M577 System Configuration Diagram

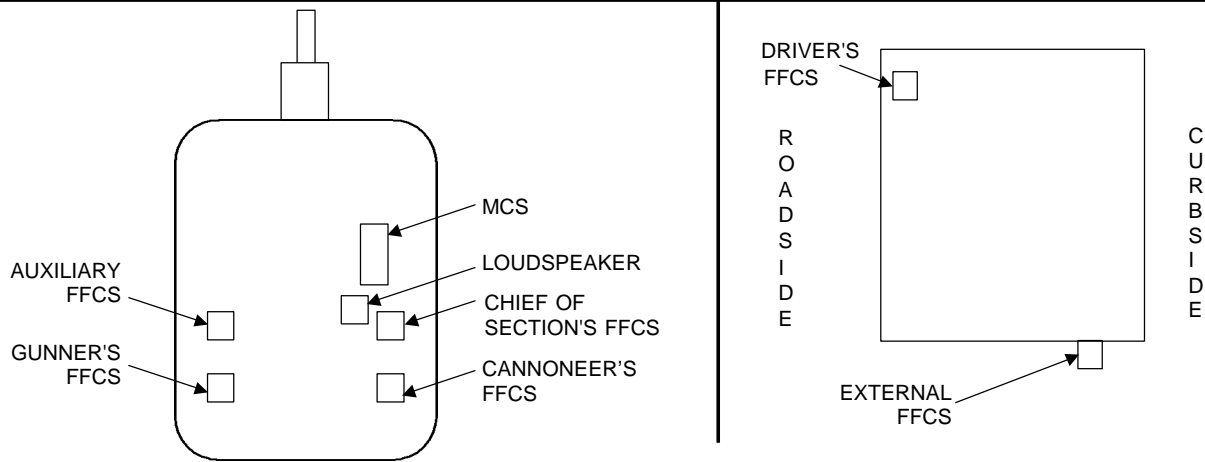
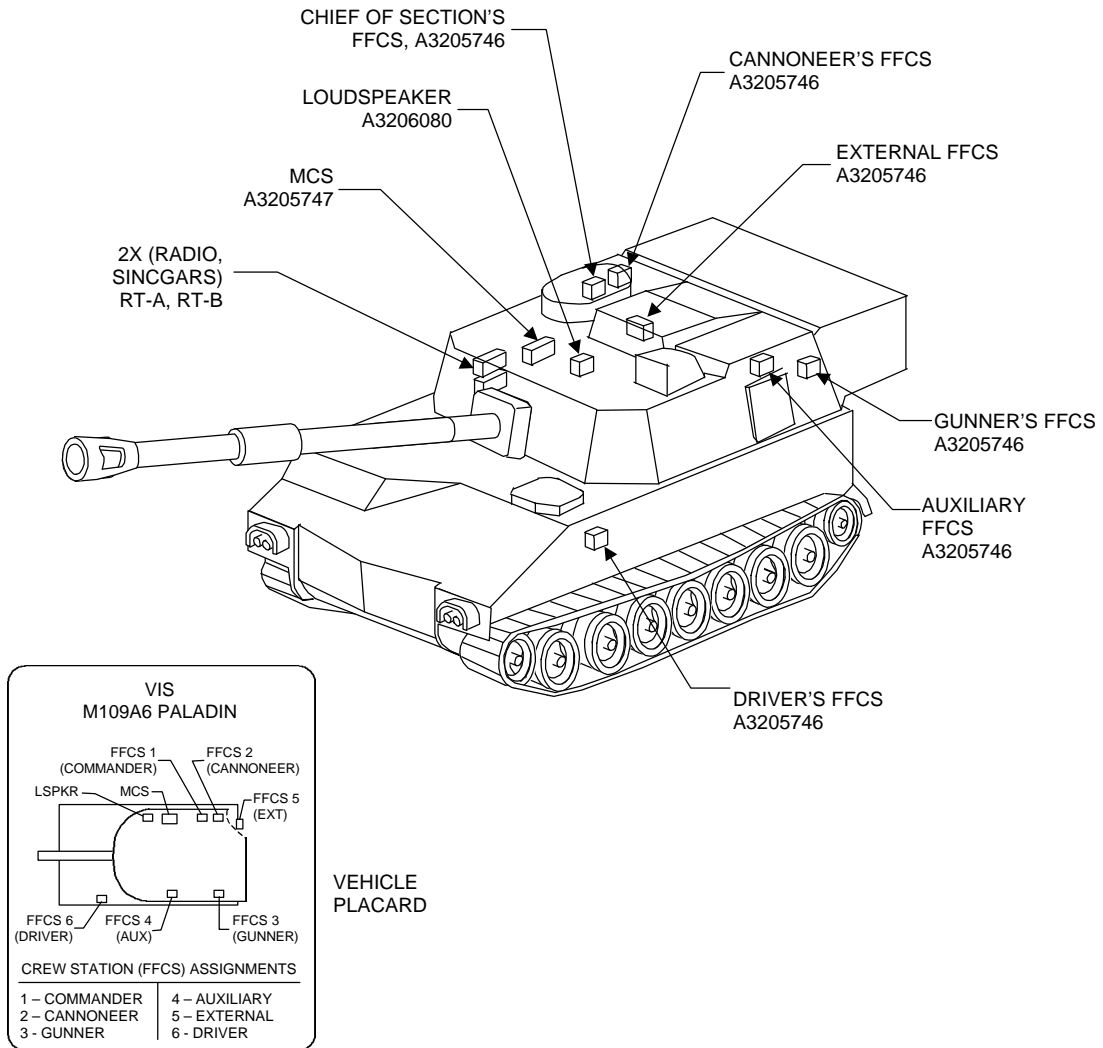
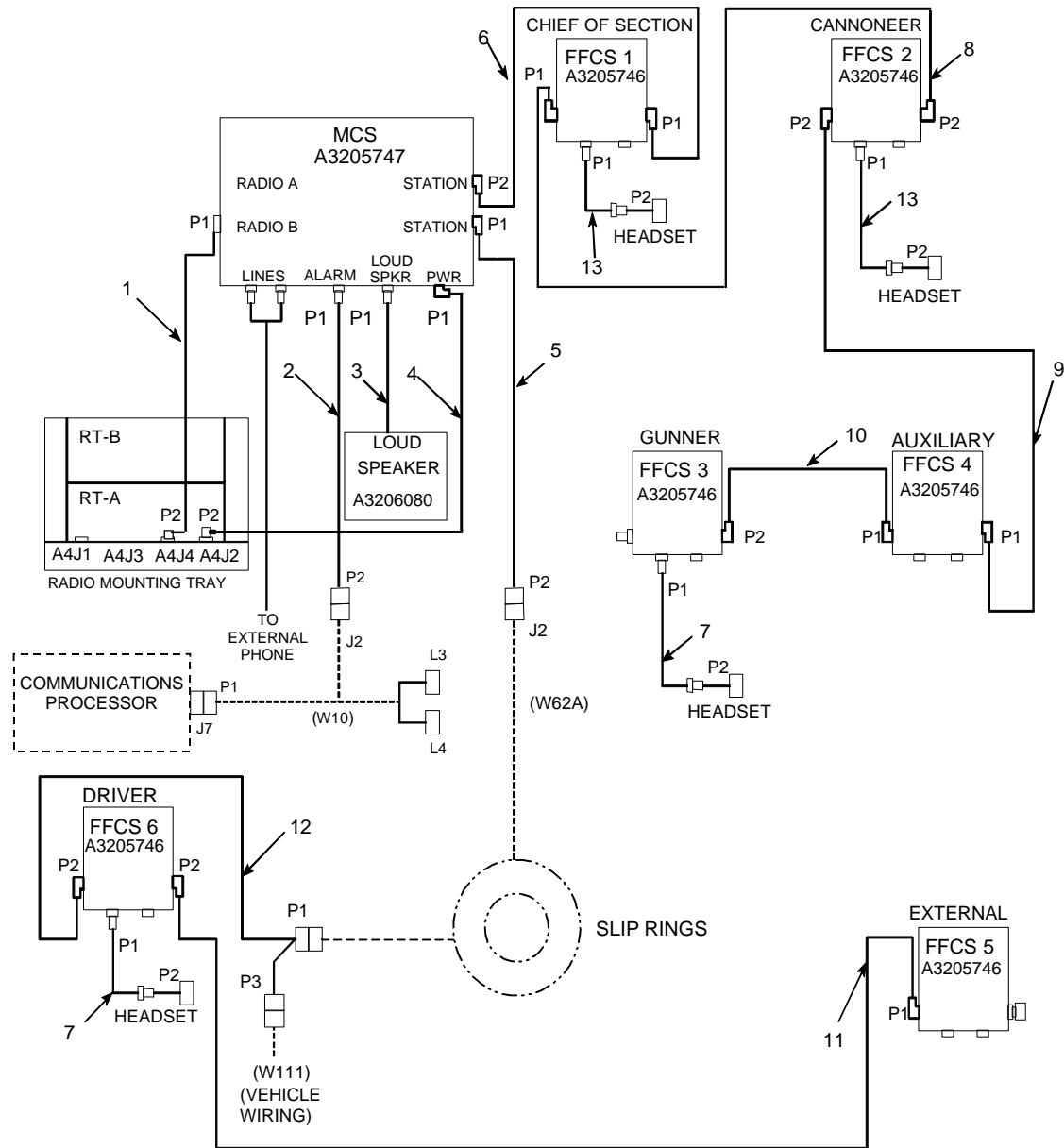

Figure 2-11. M109A6 PALADIN Equipment Location Diagram



CABLE PART NUMBERS FOR M109A6 VEHICLE

- 1. A3206019-6 (RECEIVE/TRANSMIT)
- 2. A3206021-1 (ALARM)
- 3. A3206193-6 (LOUDSPEAKER)
- 4. A3206017-5 (POWER)
- 5. A3206129-2 (HIGHWAY)
- 6. A3206018-6 (HIGHWAY)
- 7. A3206020 (BAILOUT)
- 8. A3206018-3 (HIGHWAY)
- 9. A3206018-20 (HIGHWAY)
- 10. A3206018-4 (HIGHWAY)
- 11. A3206317-25 (HIGHWAY)
- 12. A3206130-10 (HIGHWAY/VEHICLE)
- 13. A3206444 (BAILOUT)

HIGHWAY CABLE PATH FOR M109A6 PALADIN VEHICLE

FROM VIS BOX	CABLE	TO VIS BOX	CABLE
MCS (TOP CONN)	#6 (P2)	FFCS 1	#6 (P1)
FFCS 1	#8 (P1)	FFCS 2	#8 (P2)
FFCS 2	#9 (P2)	FFCS 4	#9 (P1)
FFCS 4	#10 (P1)	FFCS 3	#10 (P2)
FFCS 3	RETURN		
MCS (BOT.CONN)	#5 (P1)	SLIP RING	#5 (P2)
SLIP RING	#12(P1)	FFCS 6	#12(P2)
FFCS 6	#11 (P2)	FFCS 5	#11 (P1)
FFCS 5	RETURN		

Figure 2-12. M109A6 PALADIN System Configuration Diagram

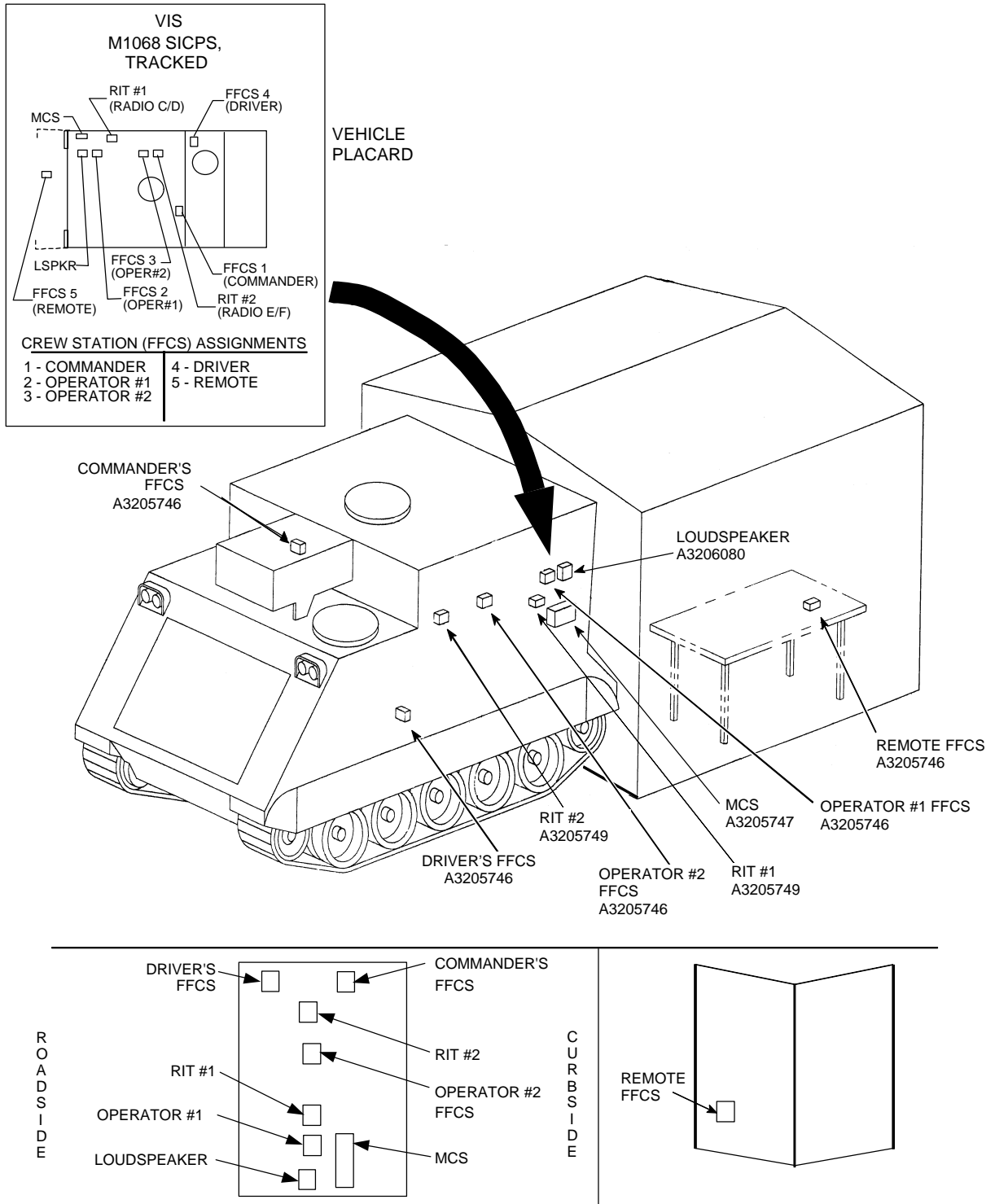

Figure 2-13. M1068 SICPS, Tracked Equipment Location Diagram

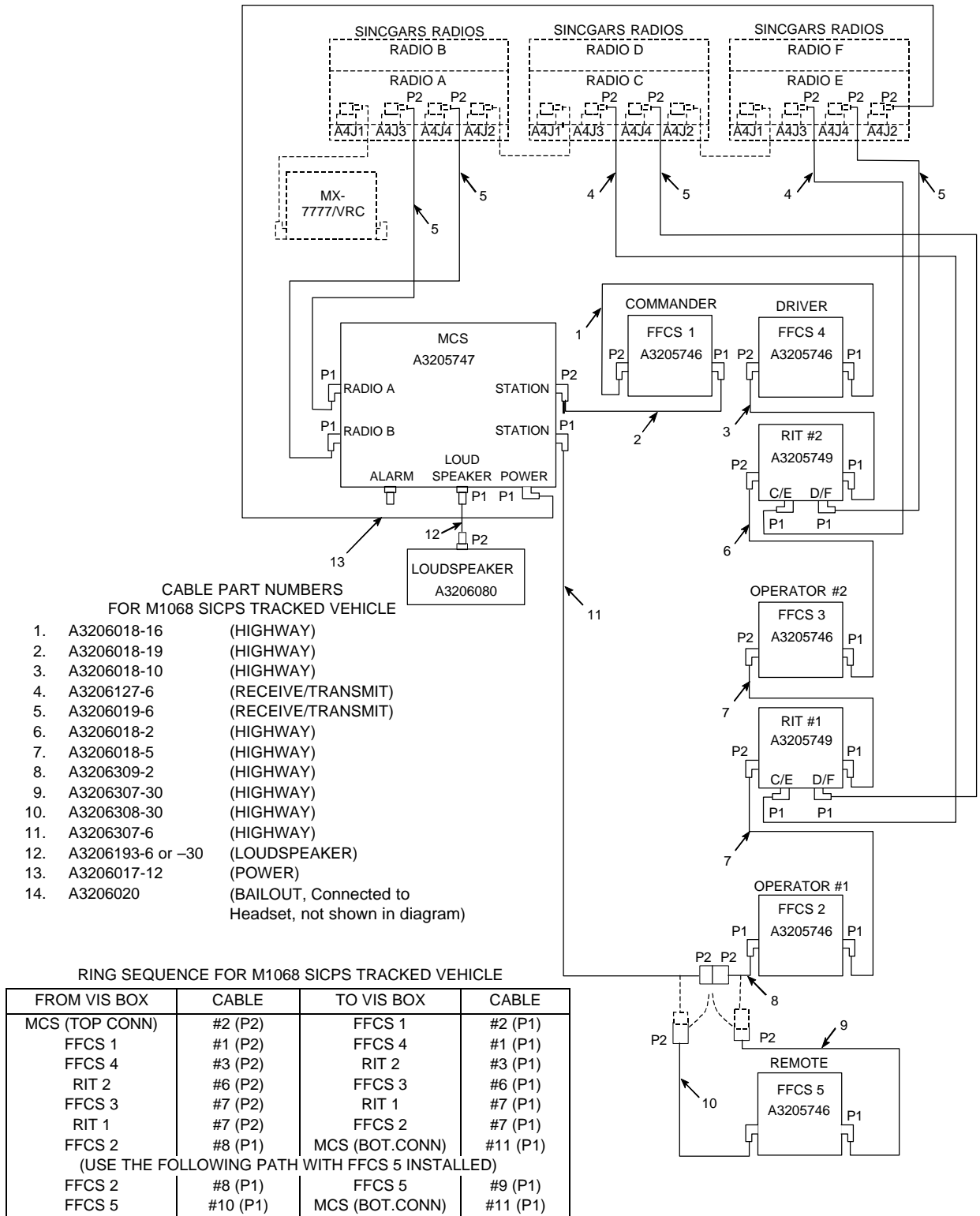

Figure 2-14. M1068 SICPS, Tracked System Configuration Diagram

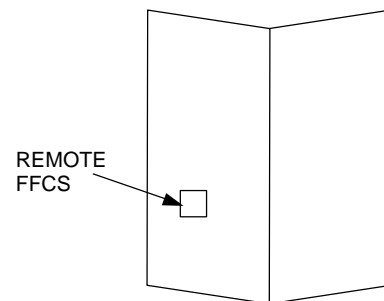
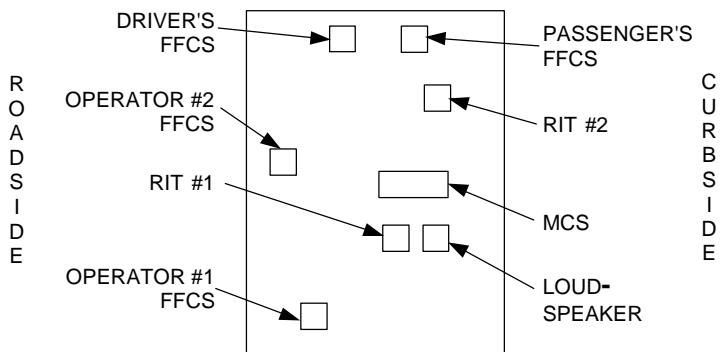
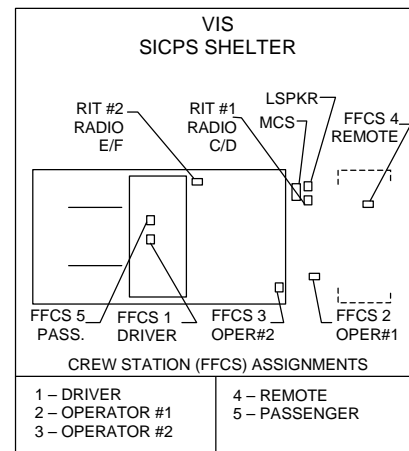
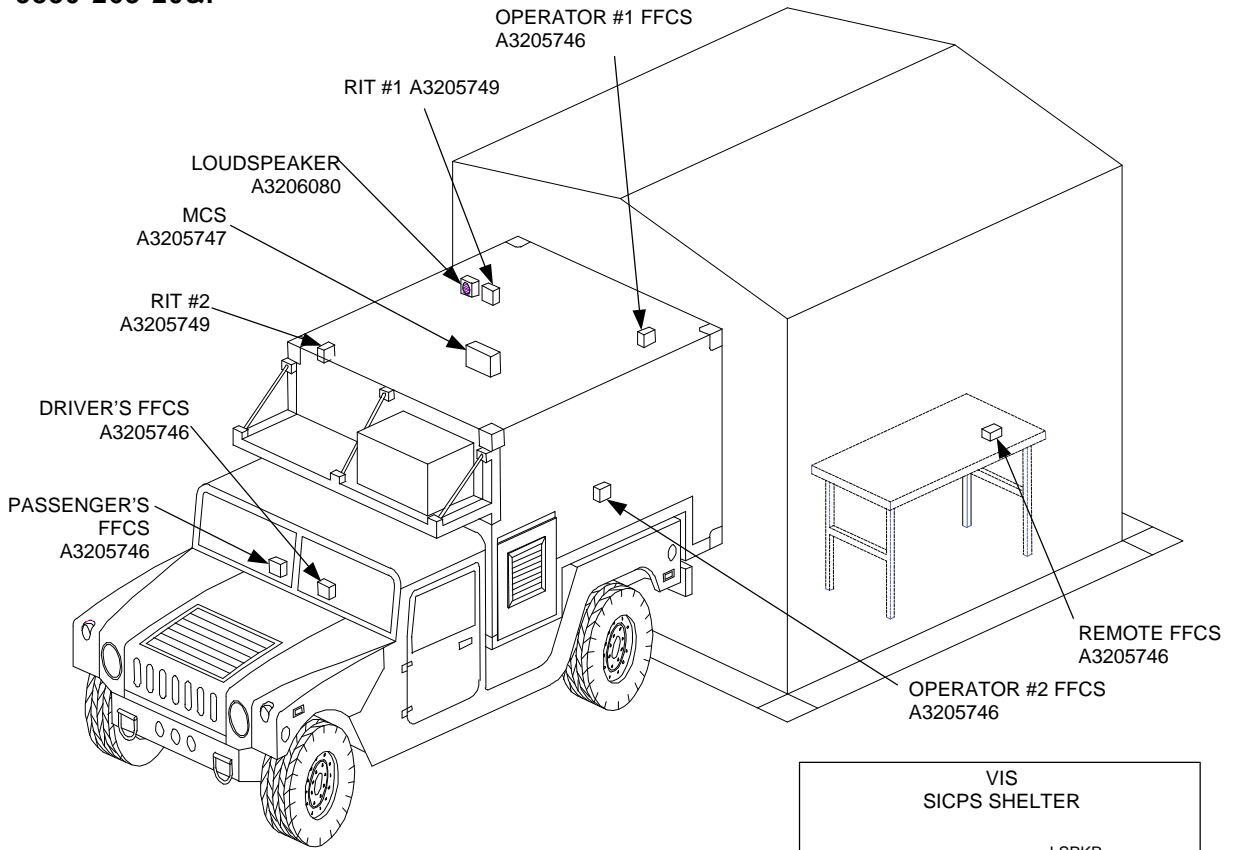

Figure 2-15. S-787 SICPS, Shelter Equipment Location Diagram

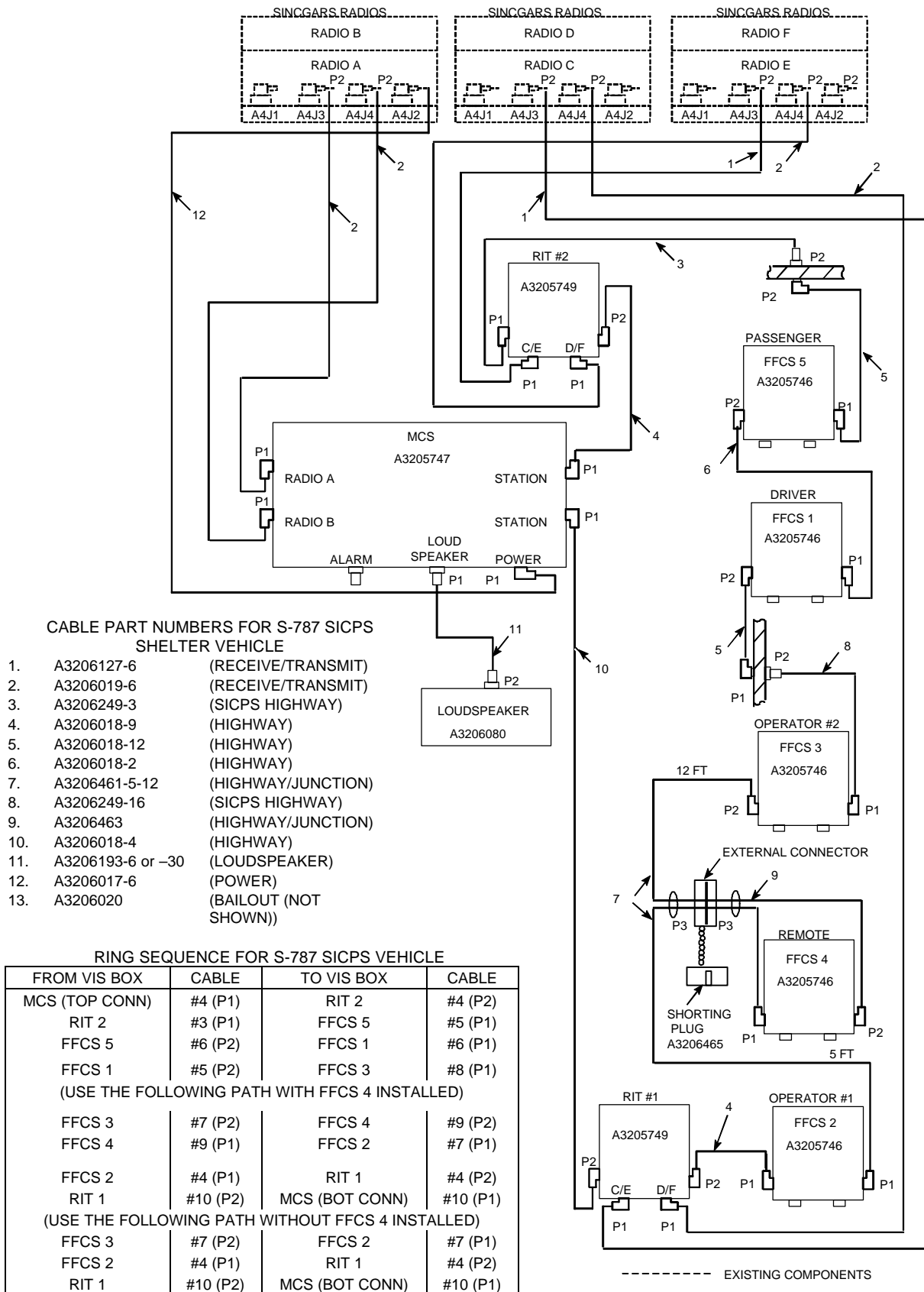

Figure 2-16. S-787 SICPS, Shelter System Configuration Diagram

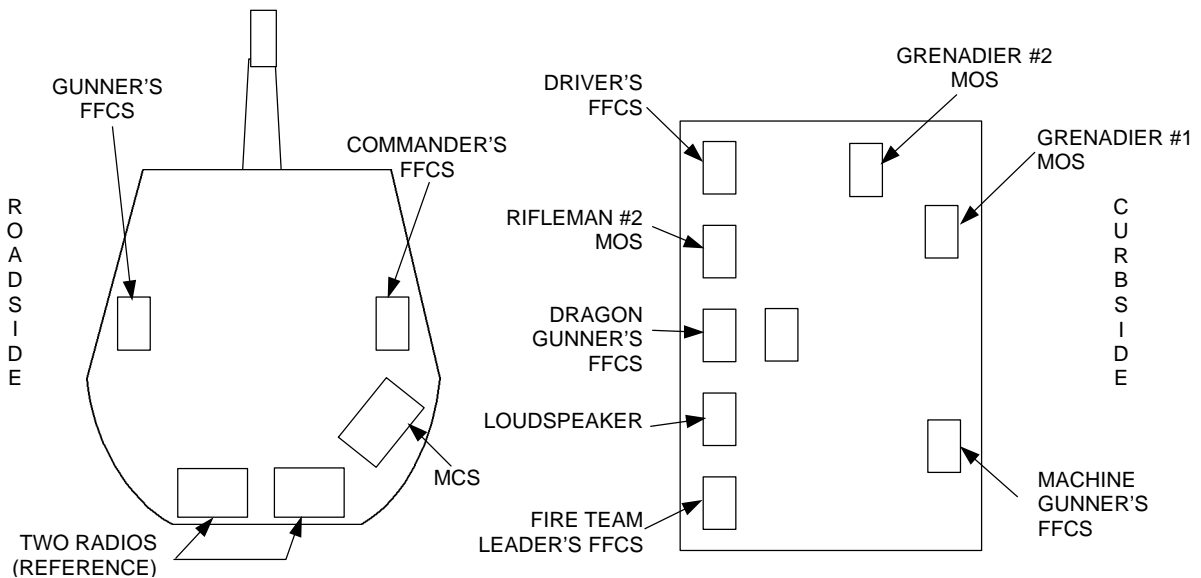
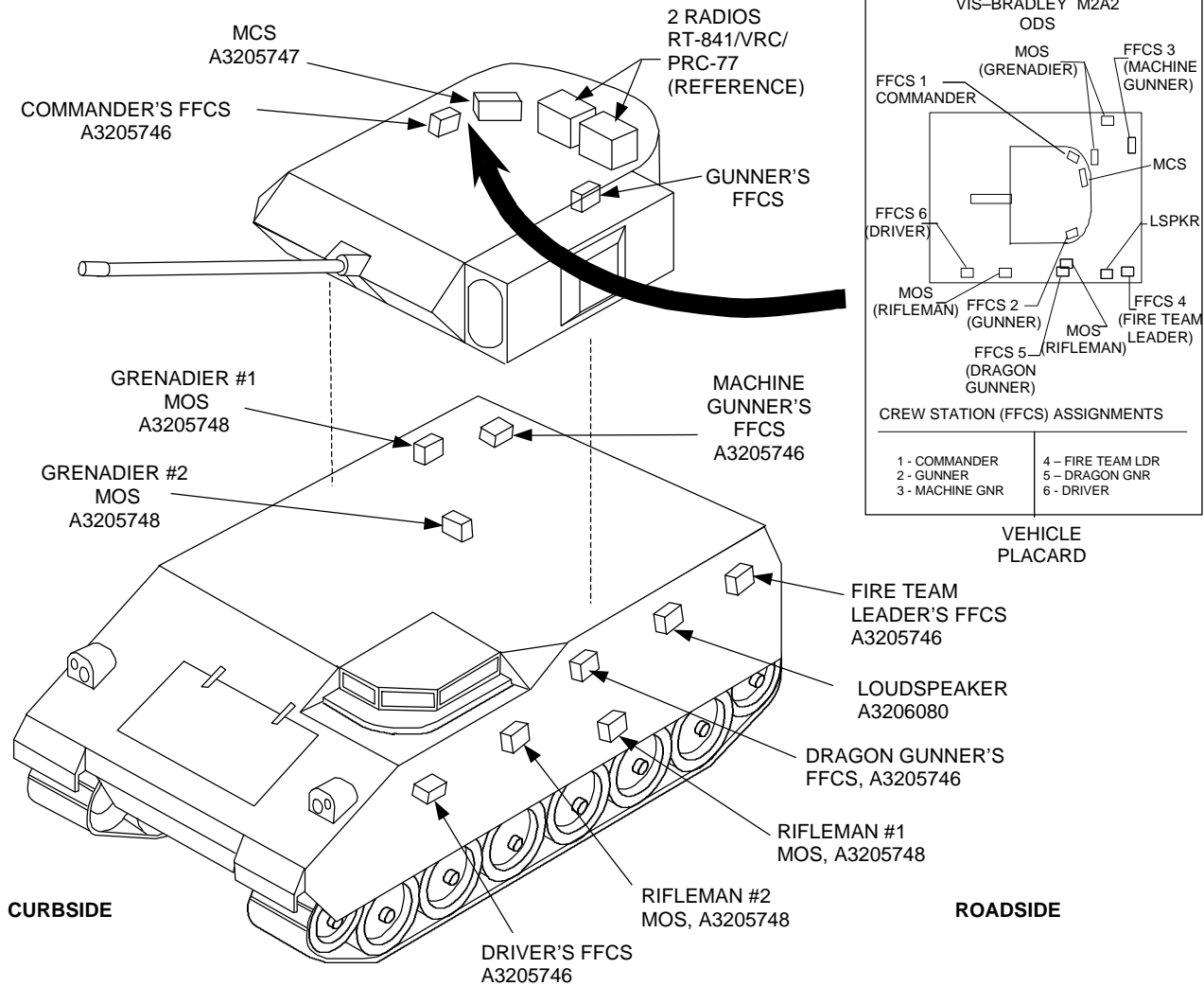
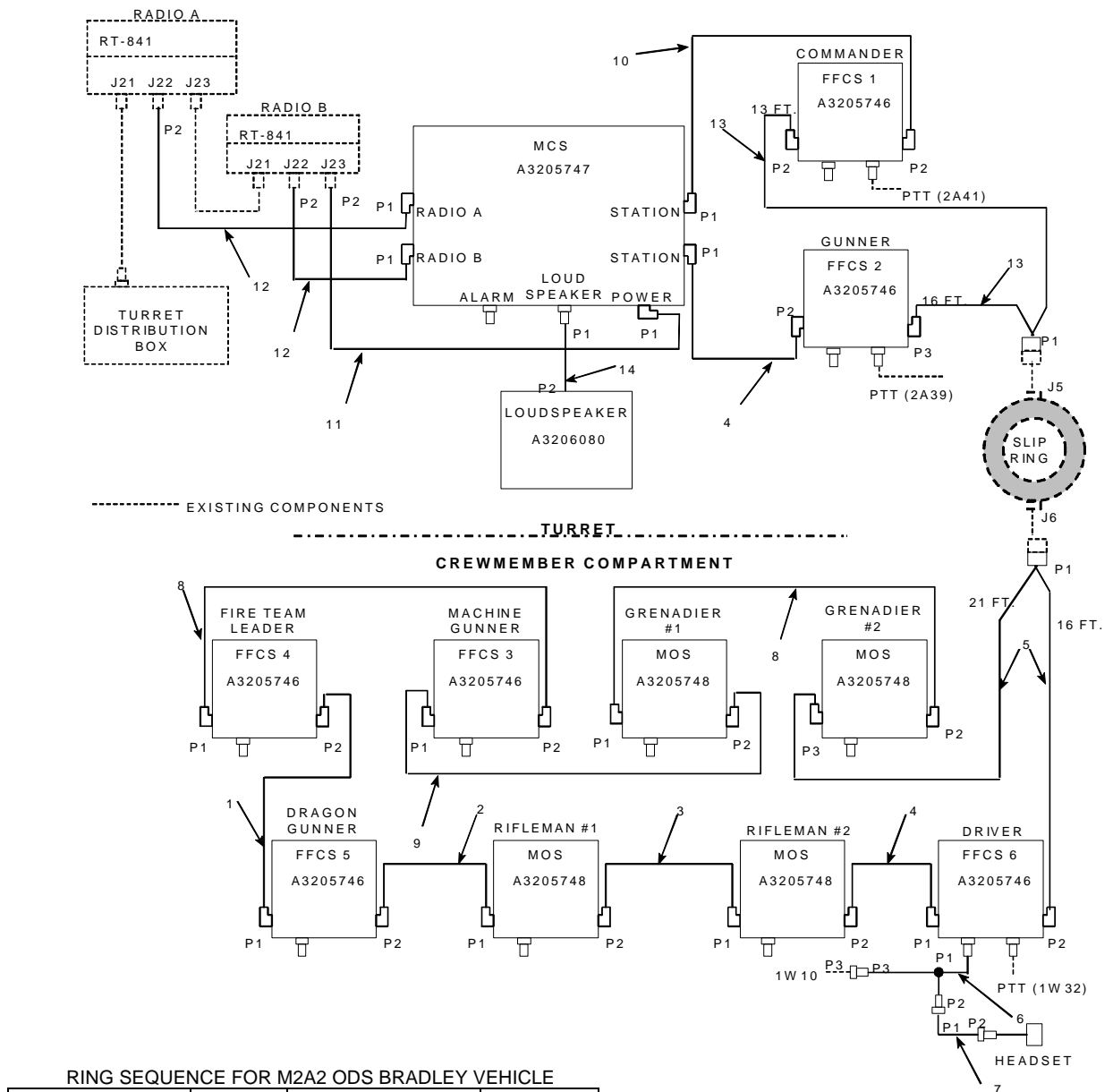

Figure 2-17. M2A2 ODS Bradley Equipment Location Diagram



RING SEQUENCE FOR M2A2 ODS BRADLEY VEHICLE

FROM VIS BOX	CABLE	TO VIS BOX	CABLE
MCS (TOP CONN)	#10 (P1)	FFCS 1	#10 (P2)
FFCS 1	#13 (P2)	SLIP RING	#13 (P1)
SLIP RING	#5 (P1)	FFCS 6	#5 (P2)
FFCS 6	#4 (P1)	MOS RIFLE # 2	#4 (P2)
MOS RIFLE # 2	#3 (P1)	MOS RIFLE # 1	#3 (P2)
MOS RIFLE # 1	#2 (P1)	FFCS 5	#2 (P2)
FFCS 5	#1 (P1)	FFCS 4	#1 (P2)
FFCS 4	#8 (P1)	FFCS 3	#8 (P2)
FFCS 3	#9 (P1)	MOS GREN#1	#9 (P2)
MOS GREN#1	#8 (P1)	MOS GREN#2	#8 (P2)
MOS GREN#2	#5 (P3)	SLIP RING	#5 (P1)
SLIP RING	#13 (P1)	FFCS 2	#13 (P3)
FFCS 2	#4 (P2)	MCS (BOT.CONN)	#4 (P1)

CABLE PART NUMBERS FOR M2A2 ODS BRADLEY VEHICLE

1. A3206018-6 (HIGHWAY)
2. A3206018-2 (HIGHWAY)
3. A3206018-10 (HIGHWAY)
4. A3206018-7 (HIGHWAY)
5. A3206257-16-21 (HIGHWAY/VEHICLE)
6. A3206116 (ALARM)
7. A3206020 (BAILOUT)
8. A3206018-8 (HIGHWAY)
9. A3206018-3 (HIGHWAY)
10. A3206018-4 (HIGHWAY)
11. A3206017-6 (POWER)
12. A3206019-6 (RECEIVE/TRANSMIT)
13. A3206023-13-16 (HIGHWAY)
14. A3206193-6 or 30 (LOUDSPEAKER)

Figure 2-18. M2A2 ODS Bradley System Configuration Diagram

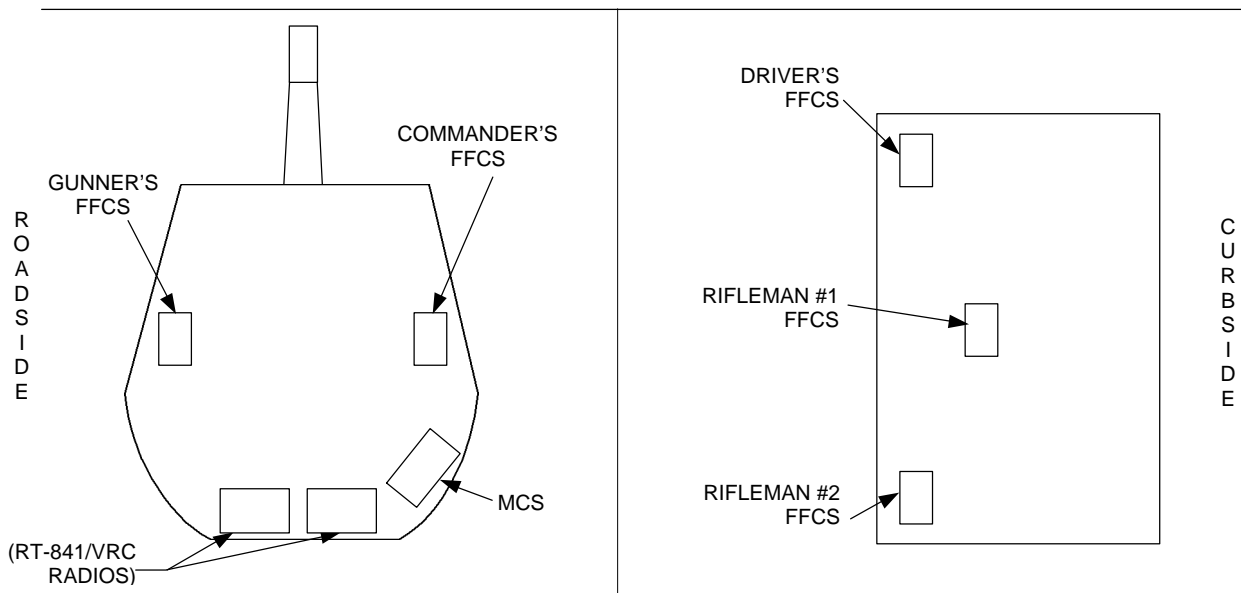
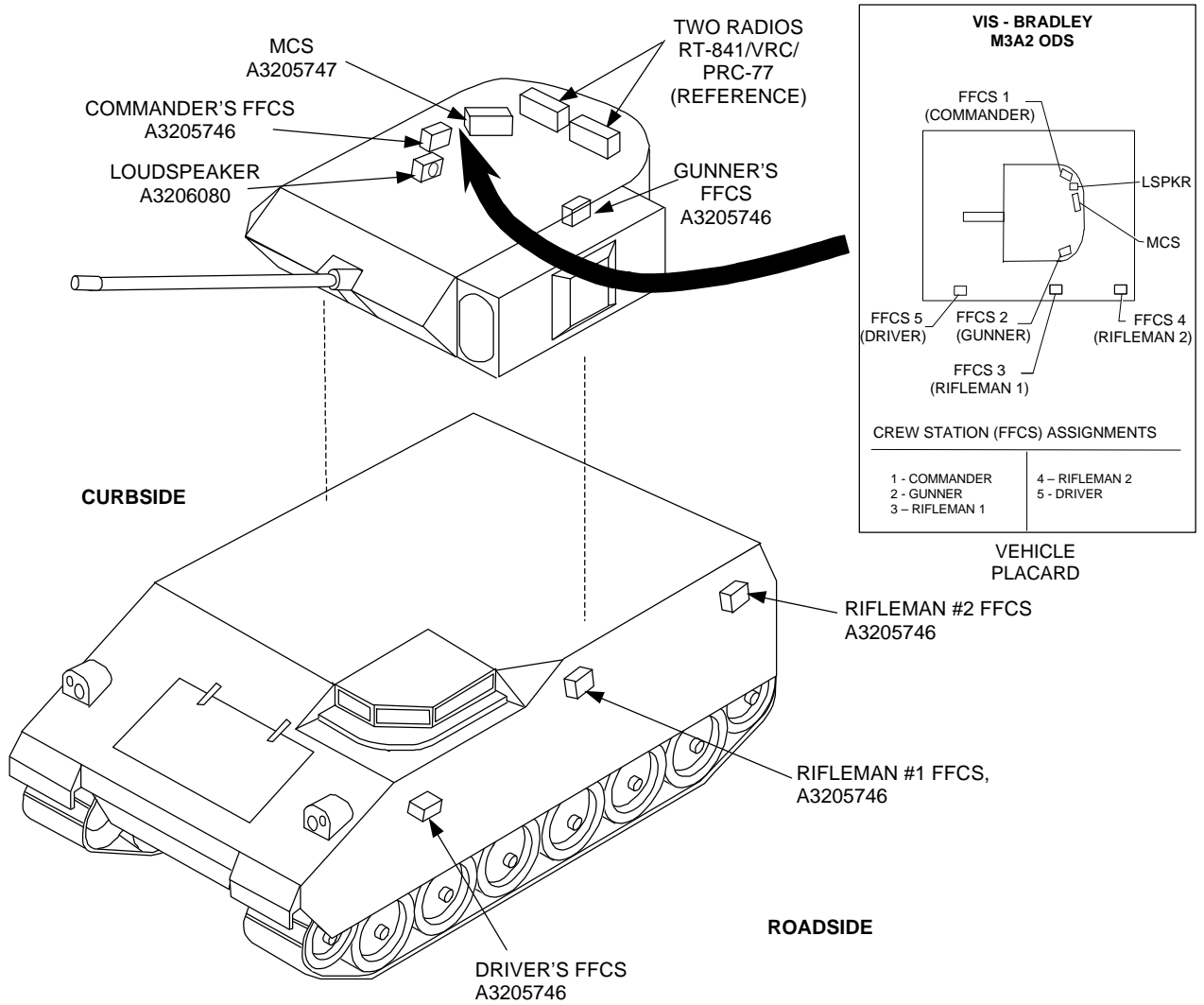

Figure 2-19. M3A2 ODS Bradley Equipment Location Diagram

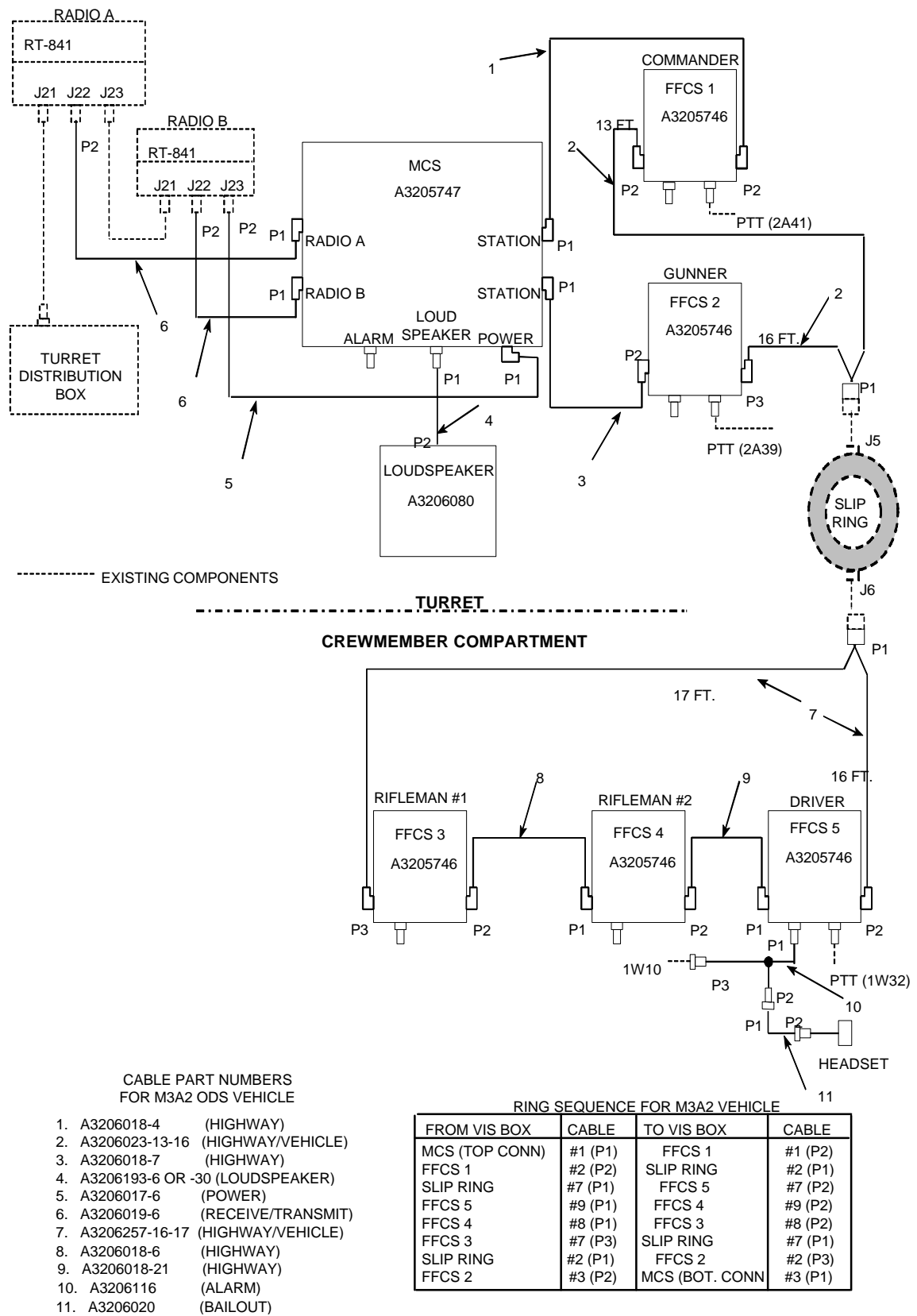

Figure 2-20. M3A2 ODS Bradley System Configuration Diagram

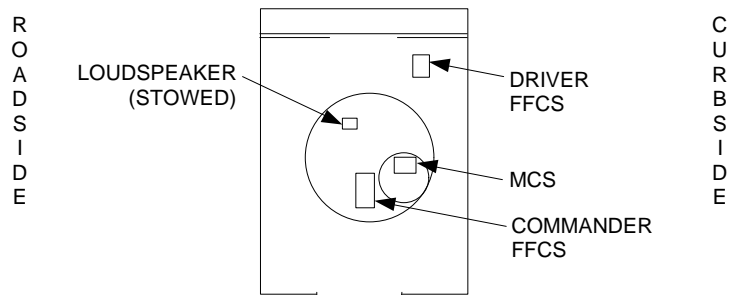
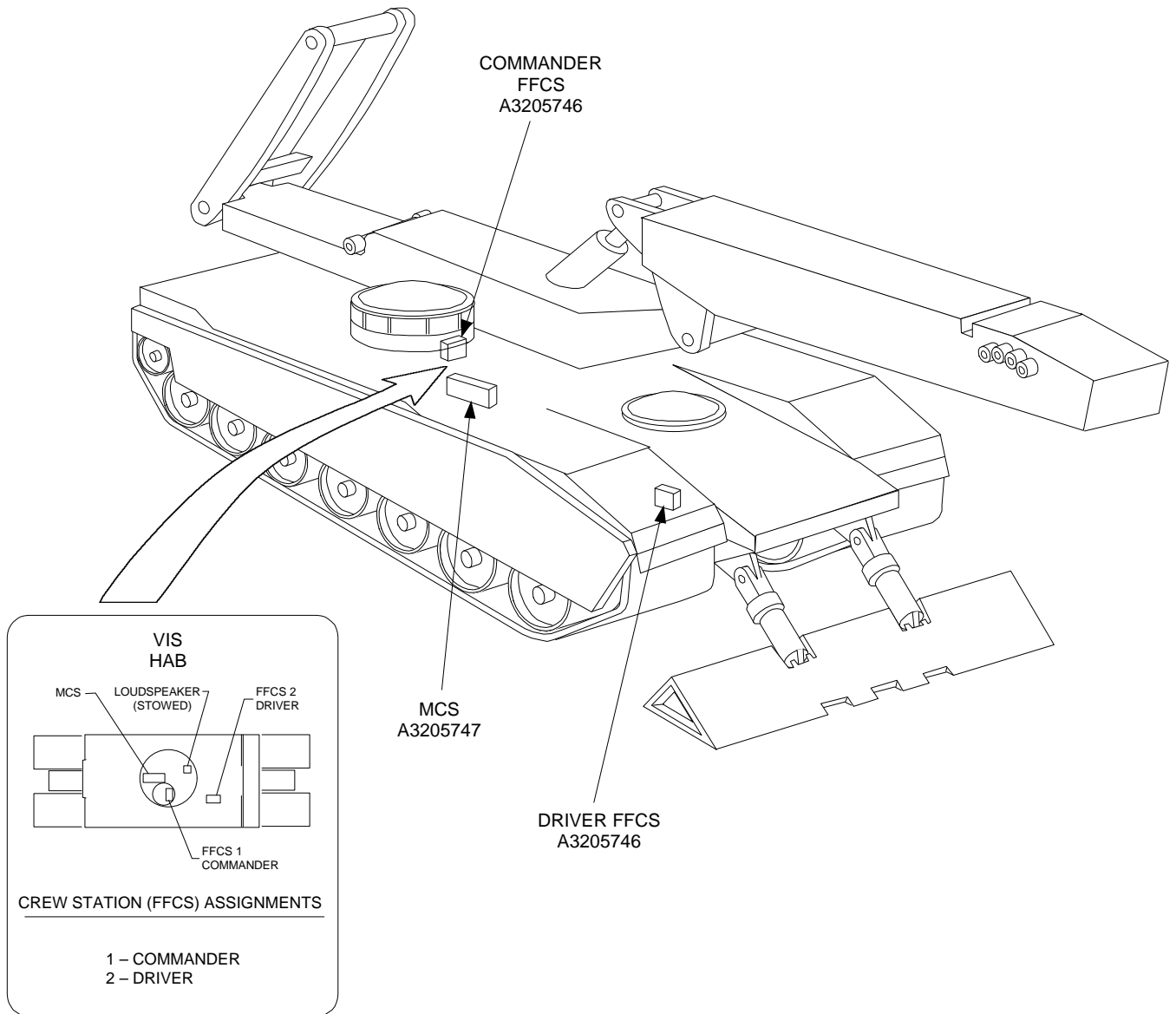
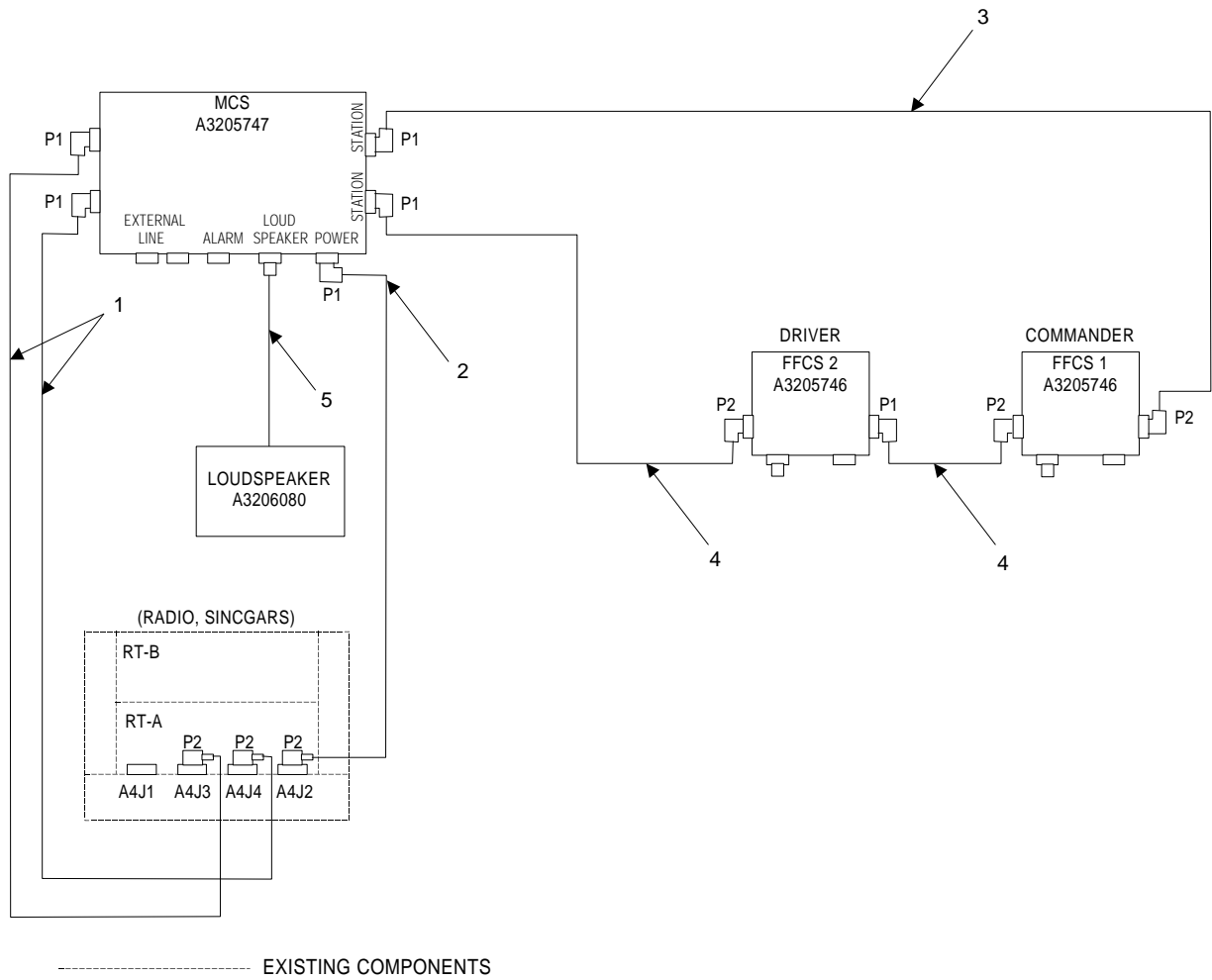

Figure 2-21. HAB Equipment Location Diagram



CABLE PART NUMBERS FOR HAB

- 1. A3206019-6 (RECEIVE/TRANSMIT)
- 2. A3206017-5 (POWER)
- 3. A3206018-2 (HIGHWAY)
- 4. A3206018-11 (HIGHWAY)
- 5. A3206193-6 or -30 (LOUDSPEAKER)

RING SEQUENCE FOR HAB

FROM VIS BOX	CABLE	TO VIS BOX	CABLE
MCS (TOP CONN)	#3 (P1)	FFCS 1	#3 (P2)
FFCS 1	#4 (P2)	FFCS 2	#4 (P1)
FFCS 2	#4 (P2)	MCS (BOTTOM CONN)	#4 (P1)

Figure 2-22. HAB System Configuration Diagram

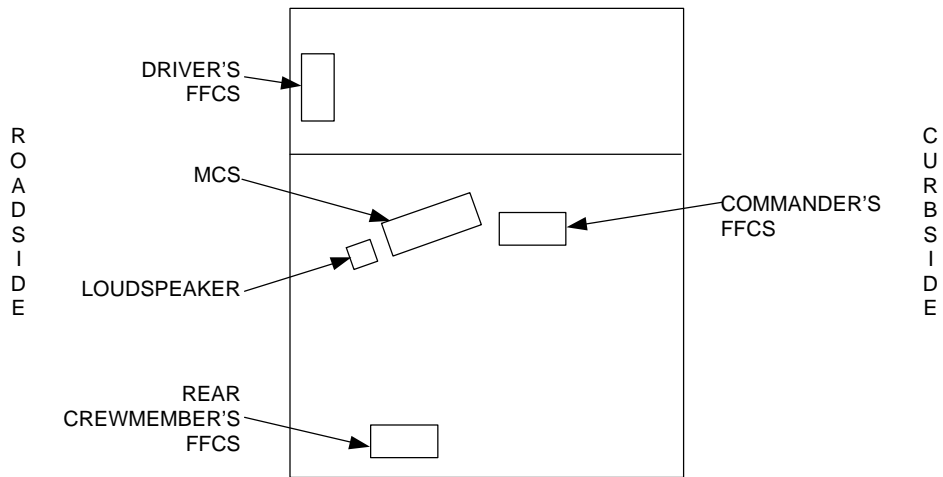
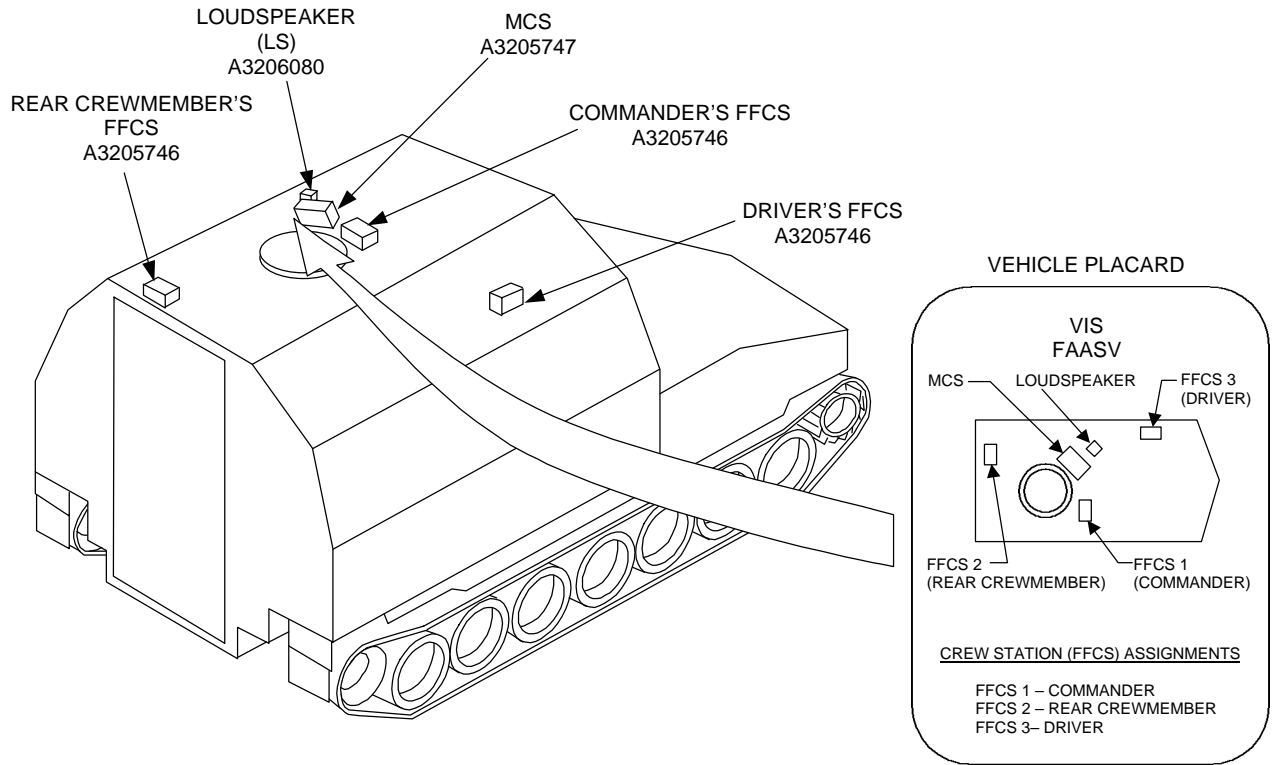
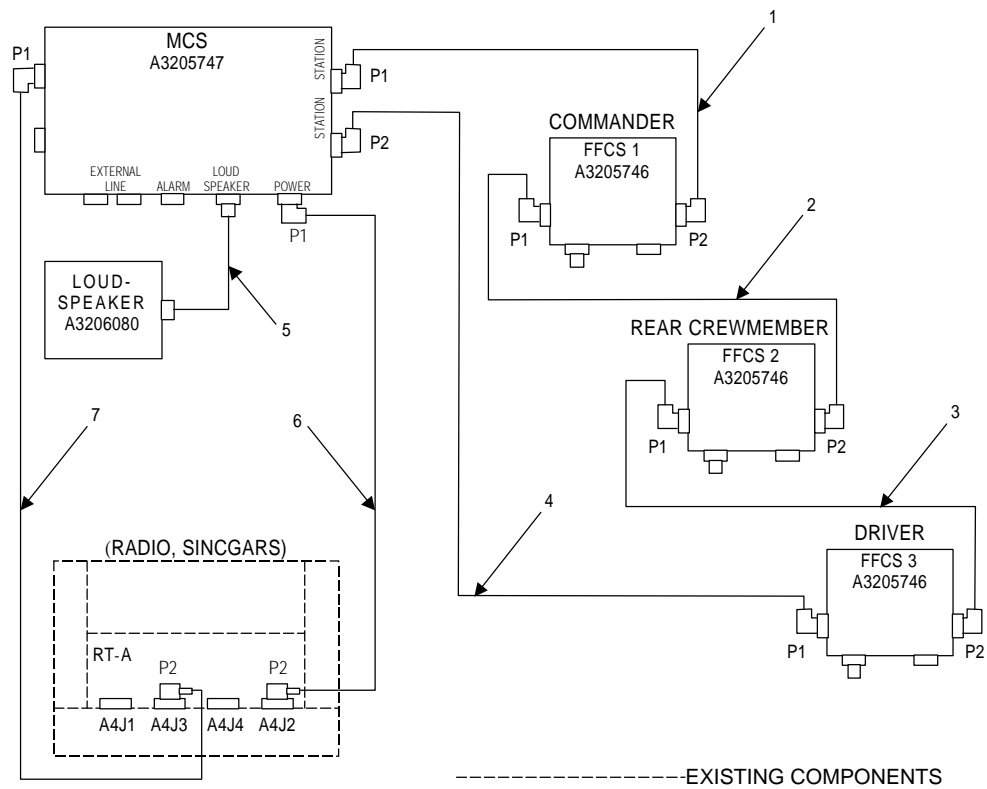

Figure 2-23. M92 FAASV Equipment Location Diagram



CABLE PART NUMBERS FOR M992 FAASV VEHICLE

- 1. A3206018-4 (HIGHWAY)
- 2. A3206018-10 (HIGHWAY)
- 3. A3206018-24 (HIGHWAY)
- 4. A3206018-18 (HIGHWAY)
- 5. A3206193-6 (LOUDSPEAKER)
- 6. A3206017-3 (POWER)
- 7. A3206019-2 (RECEIVE/TRANSMIT)

RING SEQUENCE FOR M992 VEHICLE

FROM VIS BOX	CABLE	TO VIS BOX	CABLE
MCS (TOP CONN)	#1 (P1)	FFCS 1	#1 (P2)
FFCS 1	#2 (P1)	FFCS 2	#2 (P2)
FFCS 2	#3 (P1)	FFCS 3	#3 (P2)
FFCS3	#4 (P1)	MCS (BOT CONN)	#4 (P2)

Figure 2-24. M992 FAASV System Configuration Diagram

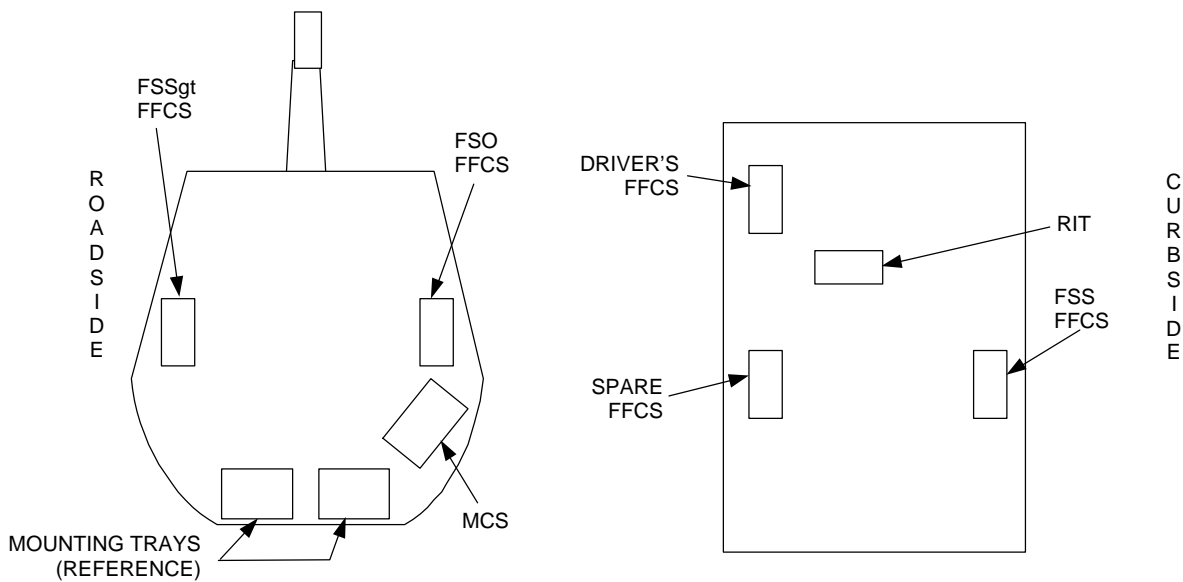
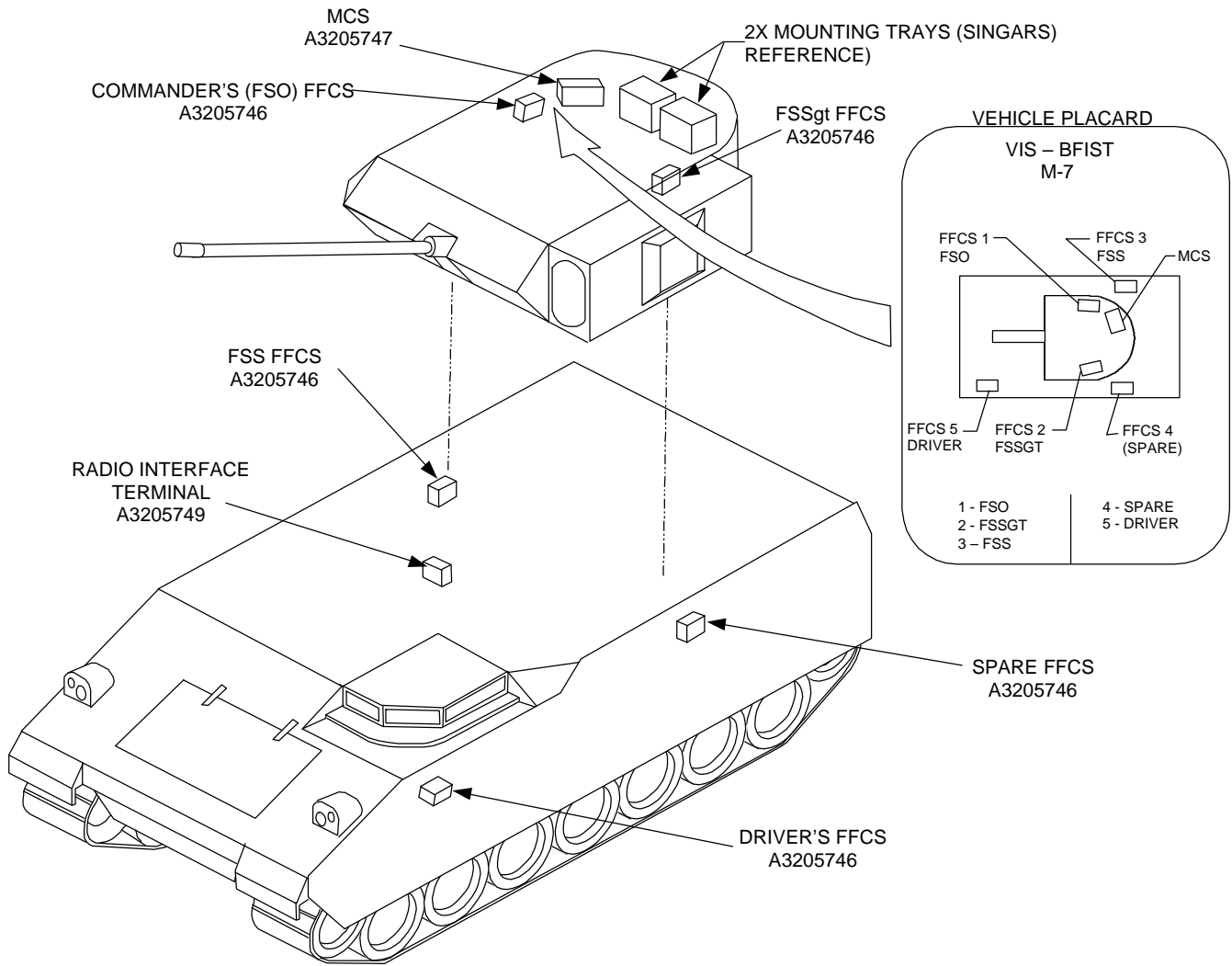
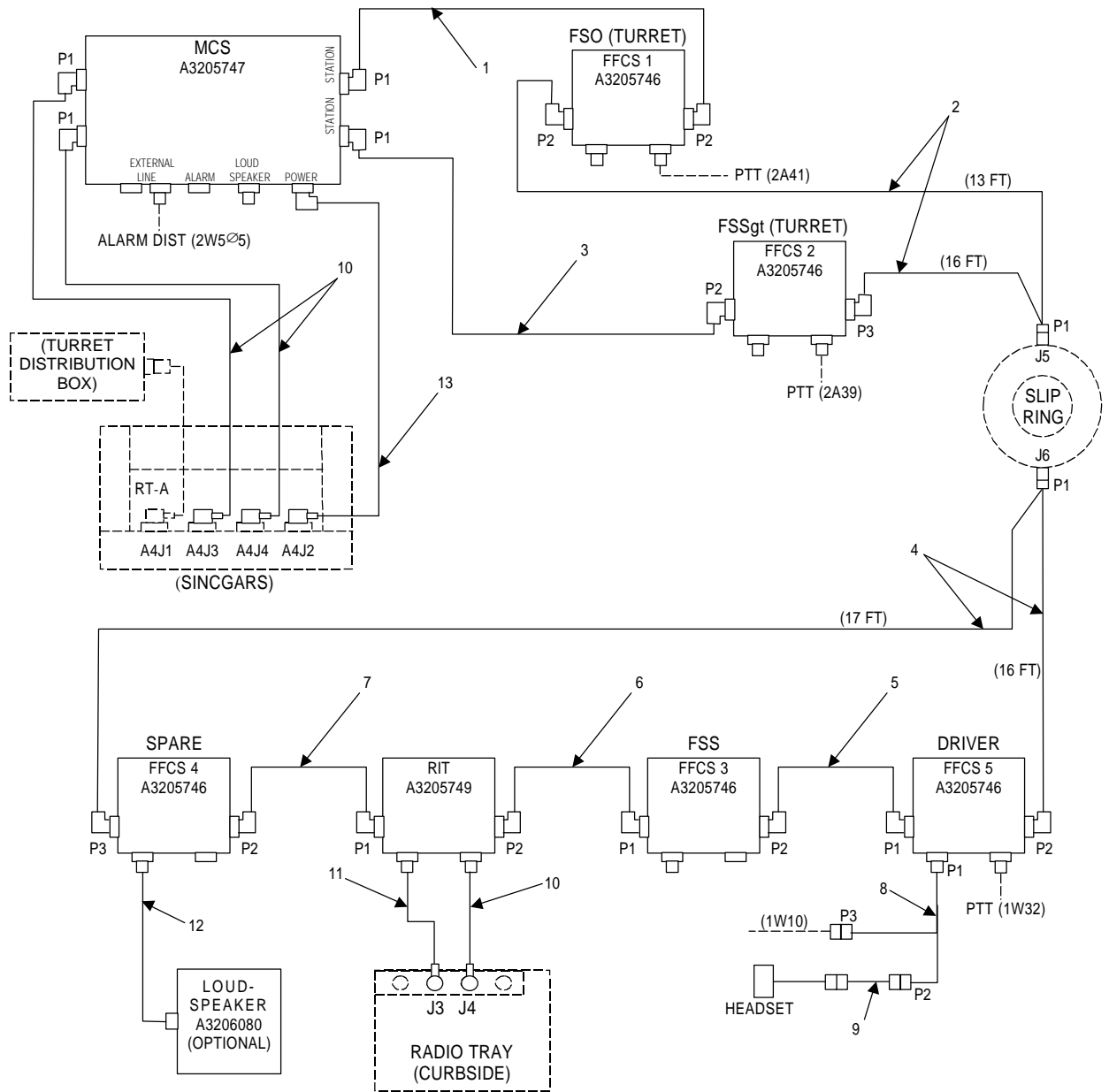

Figure 2-25. M7 BFIST Equipment Location Diagram



CABLE PART NUMBERS FOR M7 BFIST VEHICLE

- 1. A3206018-4 (HIGHWAY)
- 2. A3206023-13-16 (HIGHWAY/VEHICLE)
- 3. A3206018-7 (HIGHWAY)
- 4. A3206257-16-17 (HIGHWAY/VEHICLE)
- 5. A3206018-21 (HIGHWAY)
- 6. A3206018-6 (HIGHWAY)
- 7. A3206018-10 (HIGHWAY)
- 8. A3206116 (ALARM)
- 9. A3206020 (BAILOUT)
- 10. A3206019-6 (RECEIVE/TRANSMIT)
- 11. A3206127-6 (RECEIVE/TRANSMIT)
- 12. A3206193-6 (LOUDSPEAKER)
- 13. A3206017-6 (POWER)

RING SEQUENCE FOR M7 VEHICLE

FROM VIS BOX	CABLE	TO VIS BOX	CABLE
MCS (TOP CONN)	#1 (P1)	FFCS 1	#1 (P2)
FFCS 1	#2 (P2)	SLIP RING	#2 (P1)
SLIP RING	#4 (P1)	FFCS 5	#4 (P2)
FFCS5	#5 (P1)	FFCS 3	#5 (P2)
FFCS 3	#6 (P1)	RIT	#6 (P2)
RIT	#7 (P1)	FFCS 4	#7 (P2)
FFCS 4	#4 (P3)	SLIP RING	#4 (P1)
SLIP RING	#2 (P1)	FFCS 2	#2 (P3)
FFCS 2	#3 (P2)	MCS (BOT CONN)	#3 (P1)

Figure 2-26. M7 BFIST System Configuration Diagram

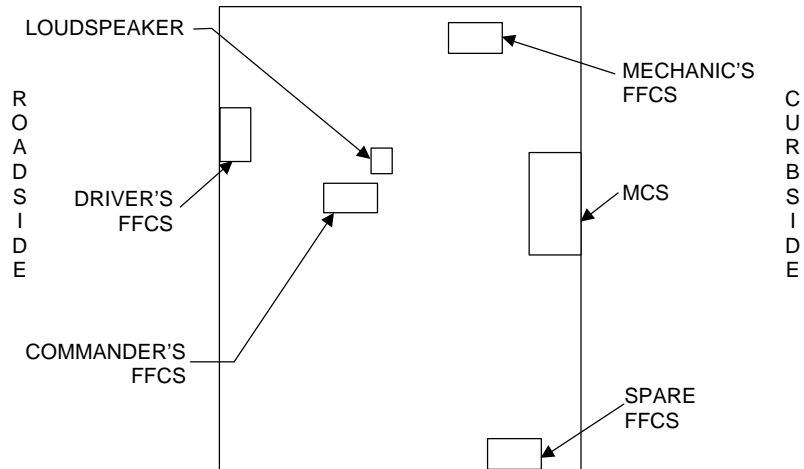
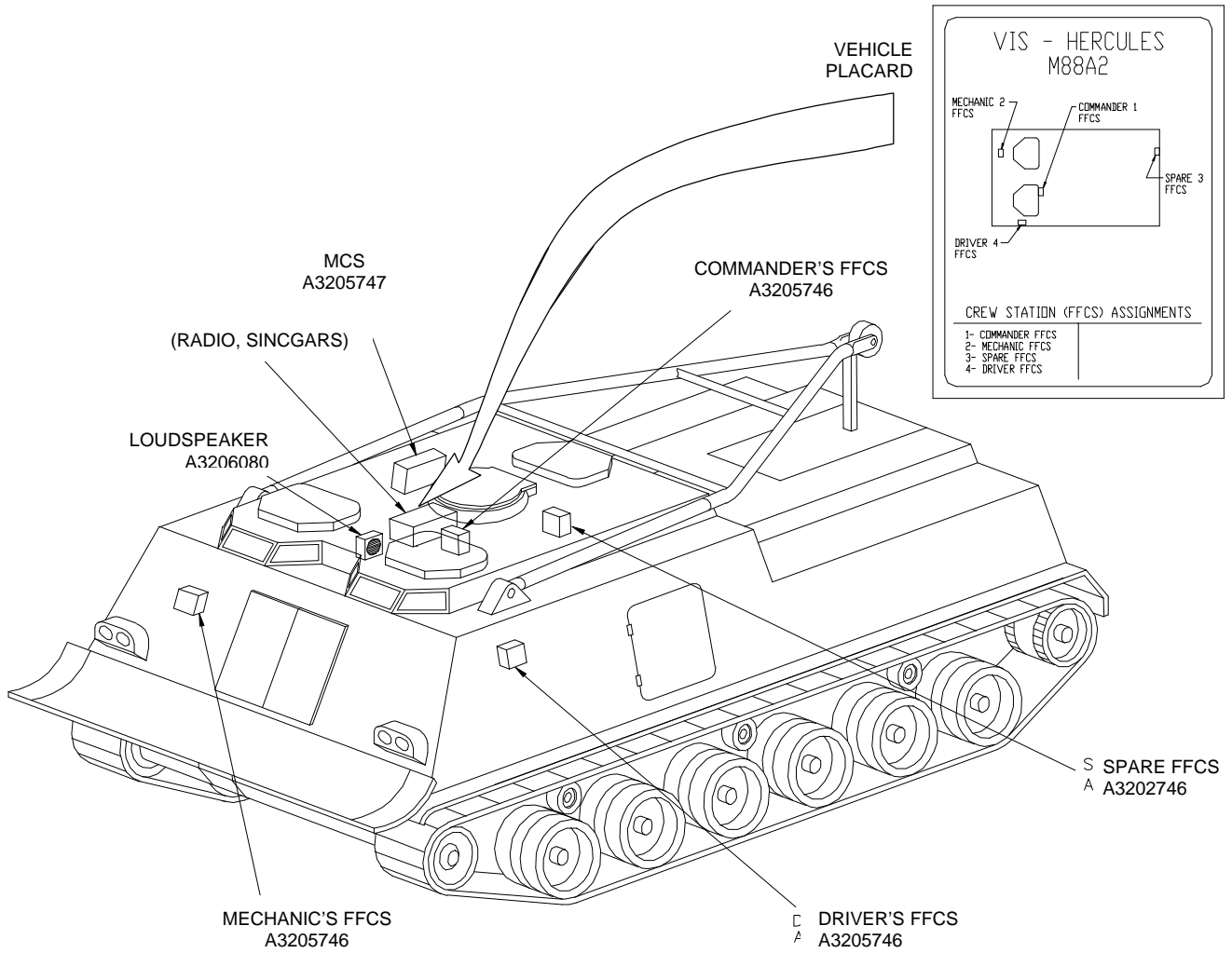
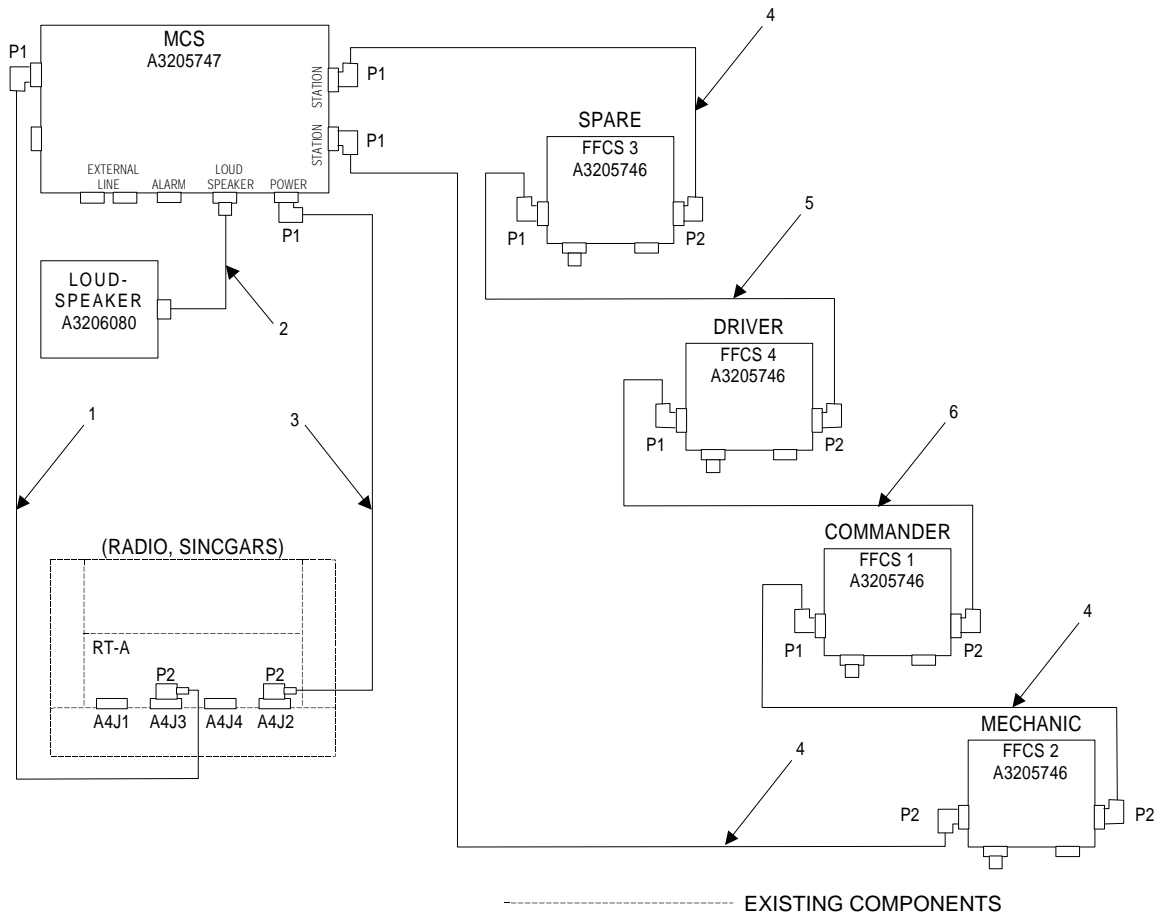

Figure 2-27. M88A2 Recovery Vehicle Equipment Location Diagram



CABLE PART NUMBERS FOR M88A2 RECOVERY VEHICLE

- | | | |
|----|-------------------|--------------------|
| 1. | A3206019-4 | (RECEIVE/TRANSMIT) |
| 2. | A3206193-6 or -30 | (LOUDSPEAKER) |
| 3. | A3206017-4 | (POWER) |
| 4. | A3206018-9 | (HIGHWAY) |
| 5. | A3206018-16 | (HIGHWAY) |
| 6. | A3206018-5 | (HIGHWAY) |

RING SEQUENCE FOR M88A2 VEHICLE

FROM VIS BOX	CABLE	TO VIS BOX	CABLE
MCS (TOP CONN)	#4 (P1)	FFCS 3	#4 (P2)
FFCS 3	#5 (P1)	FFCS 4	#5 (P2)
FFCS 4	#6 (P1)	FFCS 1	#6 (P2)
FFCS 1	#4 (P1)	FFCS 2	#4 (P2)
FFCS 2	#4 (P2)	MCS (BOT CONN)	#4 (P1)

Figure 2-28. M88A2 Recovery Vehicle System Configuration Diagram

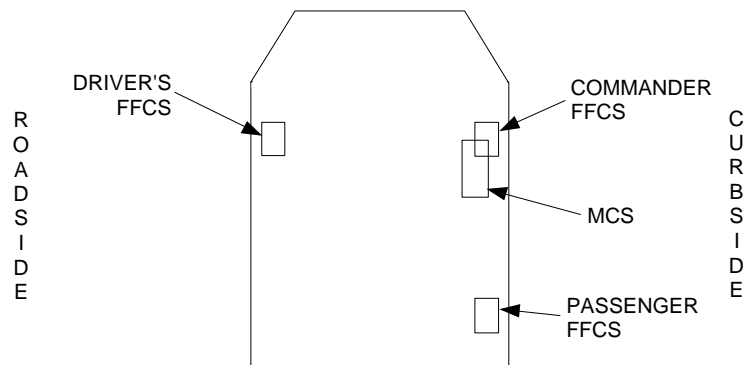
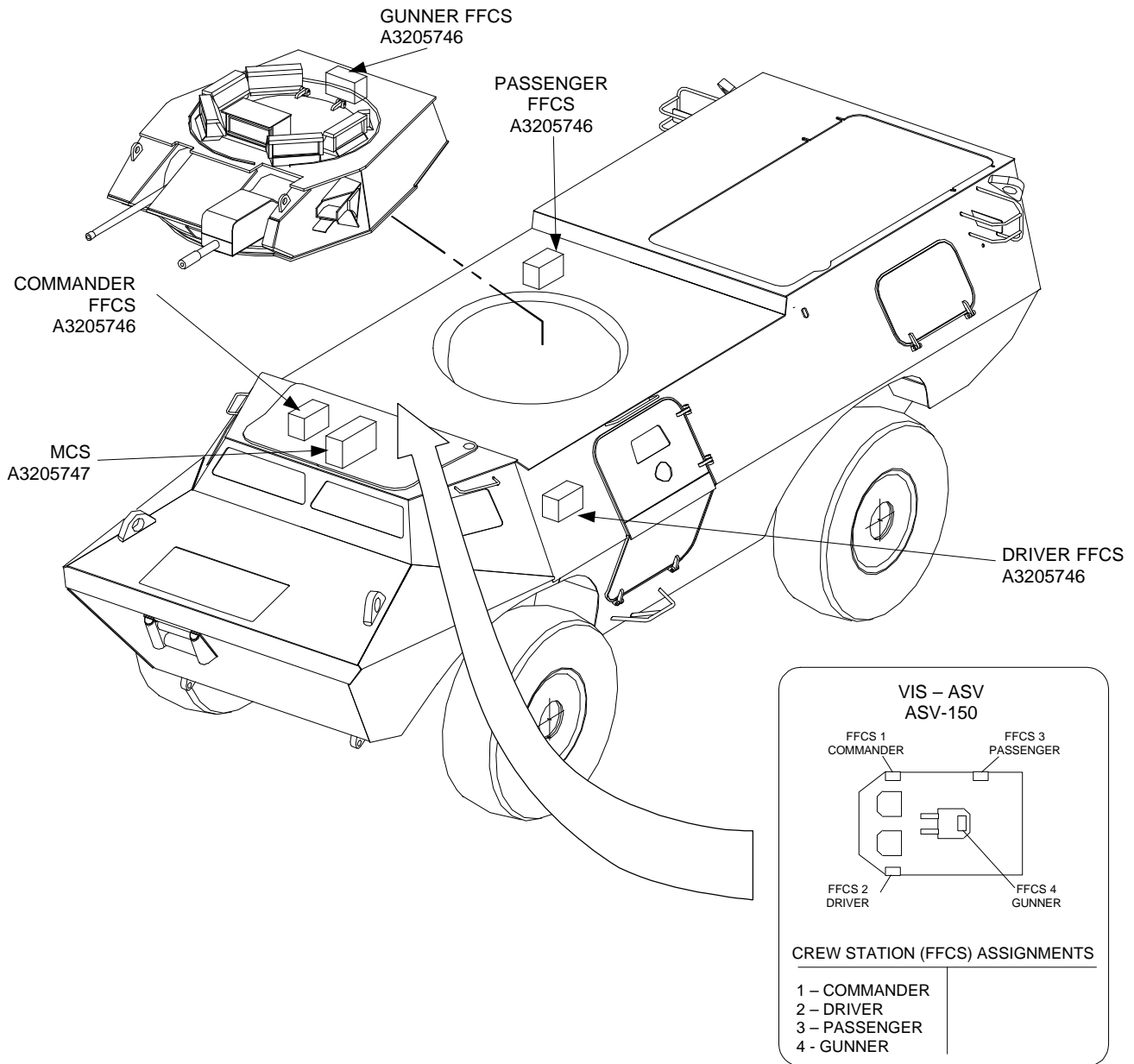
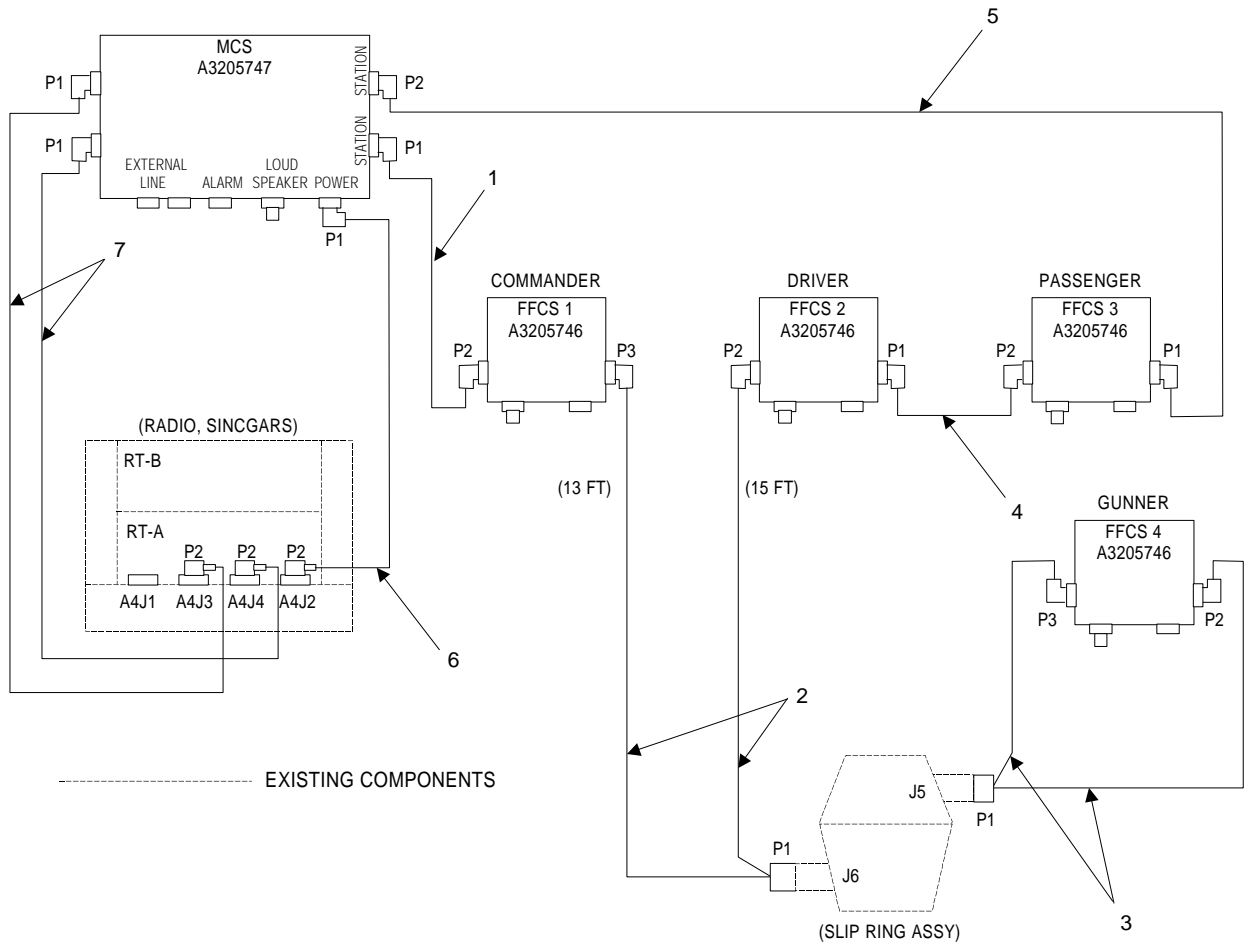

Figure 2-29. ASV Equipment Location Diagram



CABLE PART NUMBERS FOR ASV

- 1. A3206018-2 (HIGHWAY)
- 2. A3207048-13-15 (SLIP RING)
- 3. A3207048-13-13 (SLIP RING)
- 4. A3206018-17 (HIGHWAY)
- 5. A3206018-13 (HIGHWAY)
- 6. A3206017-3 (POWER)
- 7. A3206019-3 (RECEIVE/TRANSMIT)

RING SEQUENCE FOR ASV

FROM VIS BOX	CABLE	TO VIS BOX	CABLE
MCS (TOP CONN)	#5 (P2)	FFCS 3	#5 (P1)
FFCS 3	#4 (P2)	FFCS 2	#4 (P1)
FFCS 2	#2-15 (P2)	Slip Ring Assy	#2-15 (P1)
Slip Ring Assy	#3 (P1)	FFCS 4	#3 (P2)
FFCS 4	#3 (P3)	Slip Ring Assy	#3 (P1)
Slip Ring Assy	#2-13 (P1)	FFCS 1	#2-13 (P3)
FFCS 1	#1 (P2)	MCS (BOTTOM CONN)	#1 (P1)

Figure 2-30. ASV System Configuration Diagram

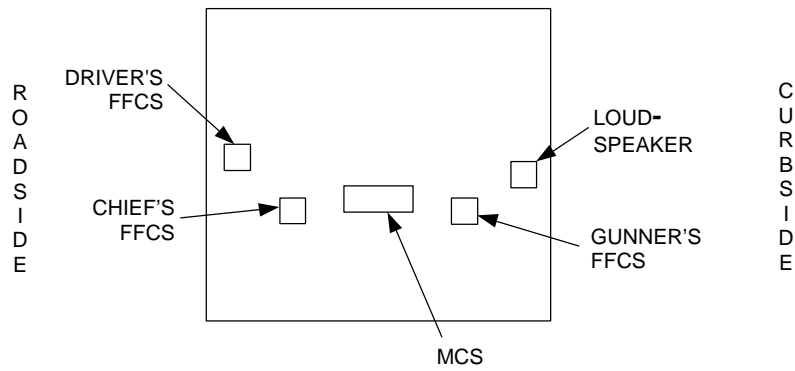
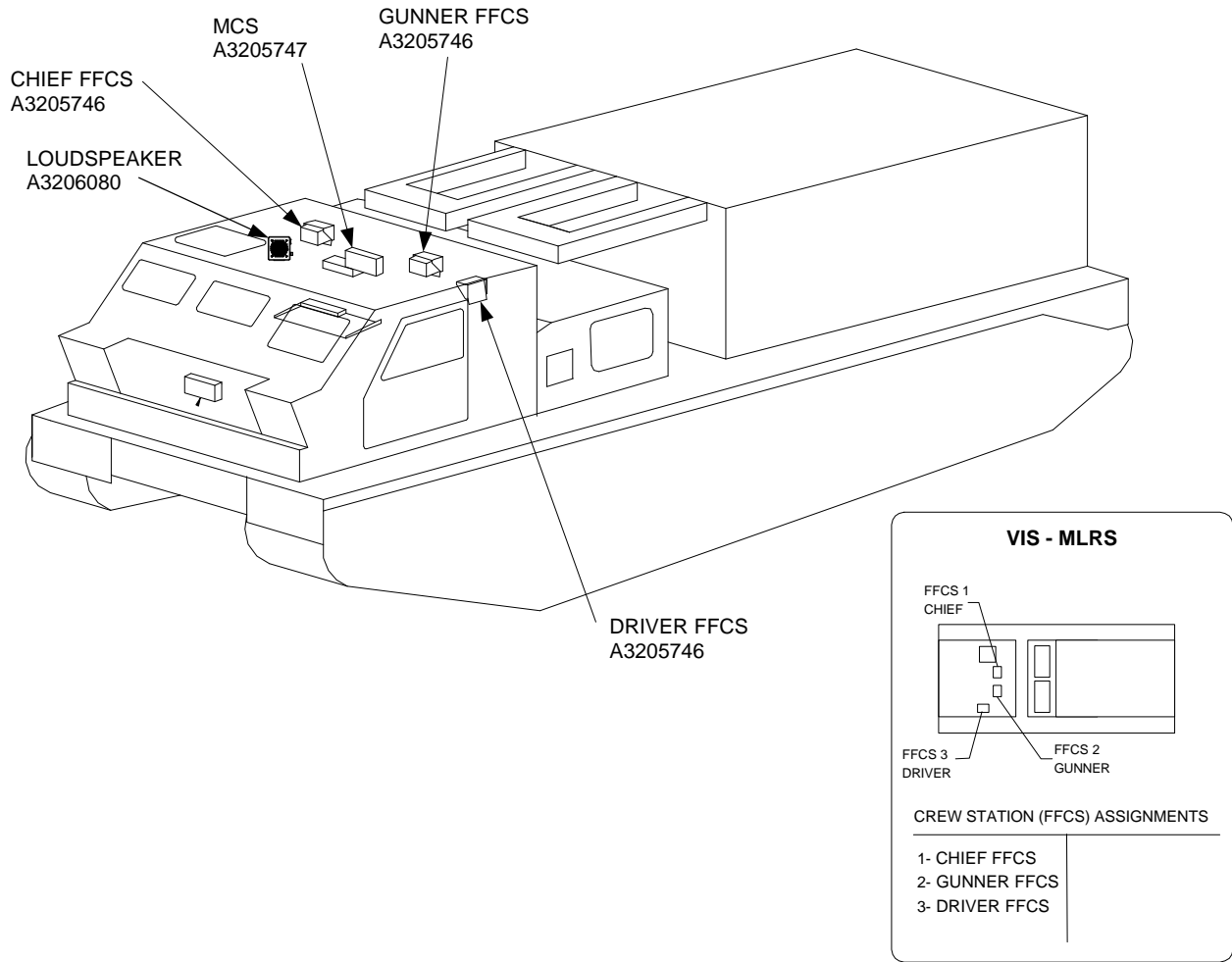
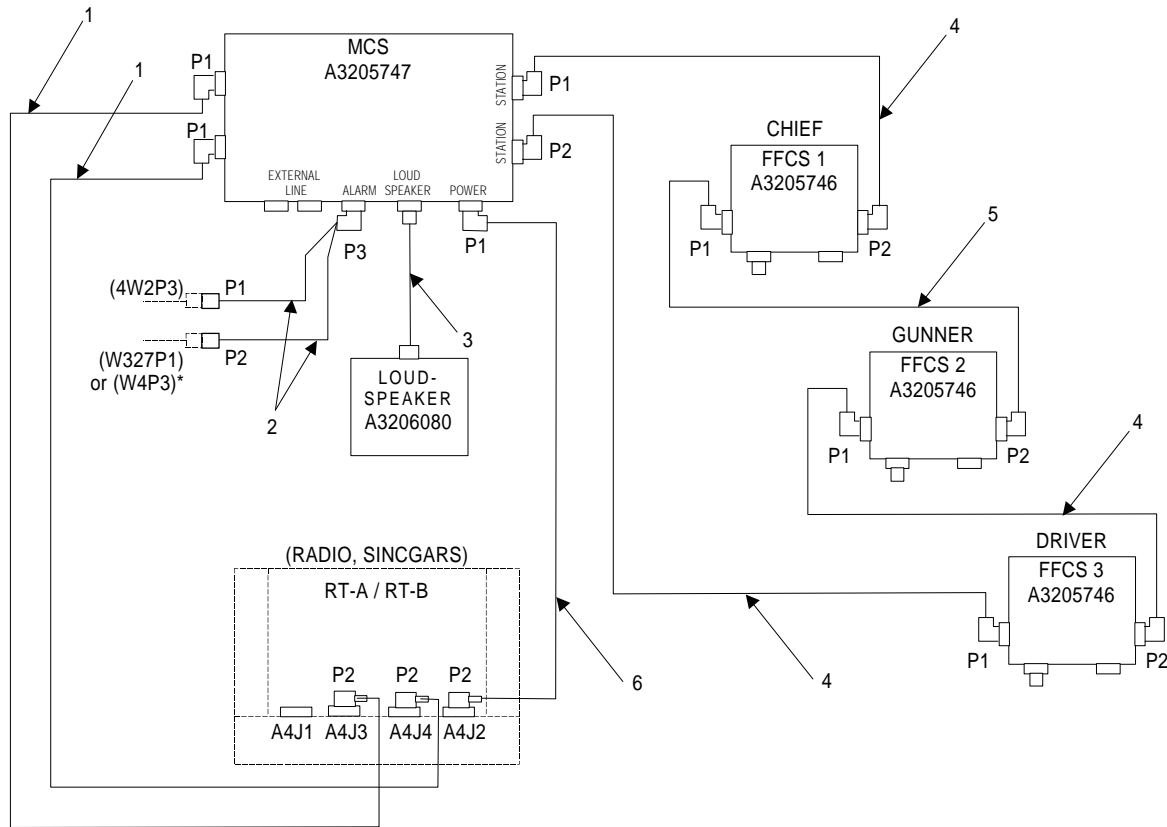

Figure 2-31. MLRS Equipment Location Diagram



* P2 connector of Alarm cable attached to W327P2 in M270A1 vehicles. P2 connector of Alarm cable attached to W4P3 in M270 vehicles.

----- EXISTING COMPONENTS

CABLE PART NUMBERS FOR MLRS

- 1. A3206019-3 (RECEIVE/TRANSMIT)
- 2. A3206618 (CABLE, SPEC PRP)
- 3. A3206193-30 (LOUDSPEAKER)
- 4. A3206018-4 (HIGHWAY)
- 5. A3206018-6 (HIGHWAY)
- 6. A3206017-3 (POWER)

RING SEQUENCE FOR MLRS

FROM VIS BOX	CABLE	TO VIS BOX	CABLE
MCS (TOP CONN)	#4 (P1)	FFCS 1	#4 (P2)
FFCS 1	#5 (P1)	FFCS 2	#5 (P2)
FFCS 2	#4 (P1)	FFCS 3	#4 (P2)
FFCS 3	#4 (P1)	MCS (BOT CONN)	#4 (P2)

Figure 2-32. MLRS System Configuration Diagram

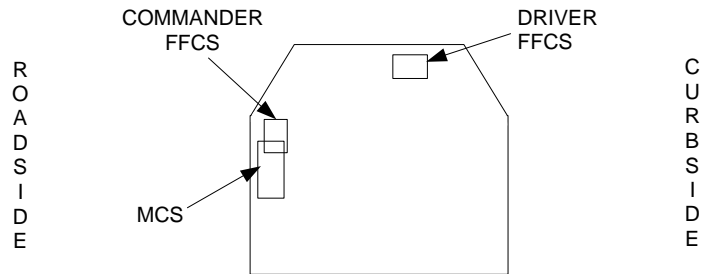
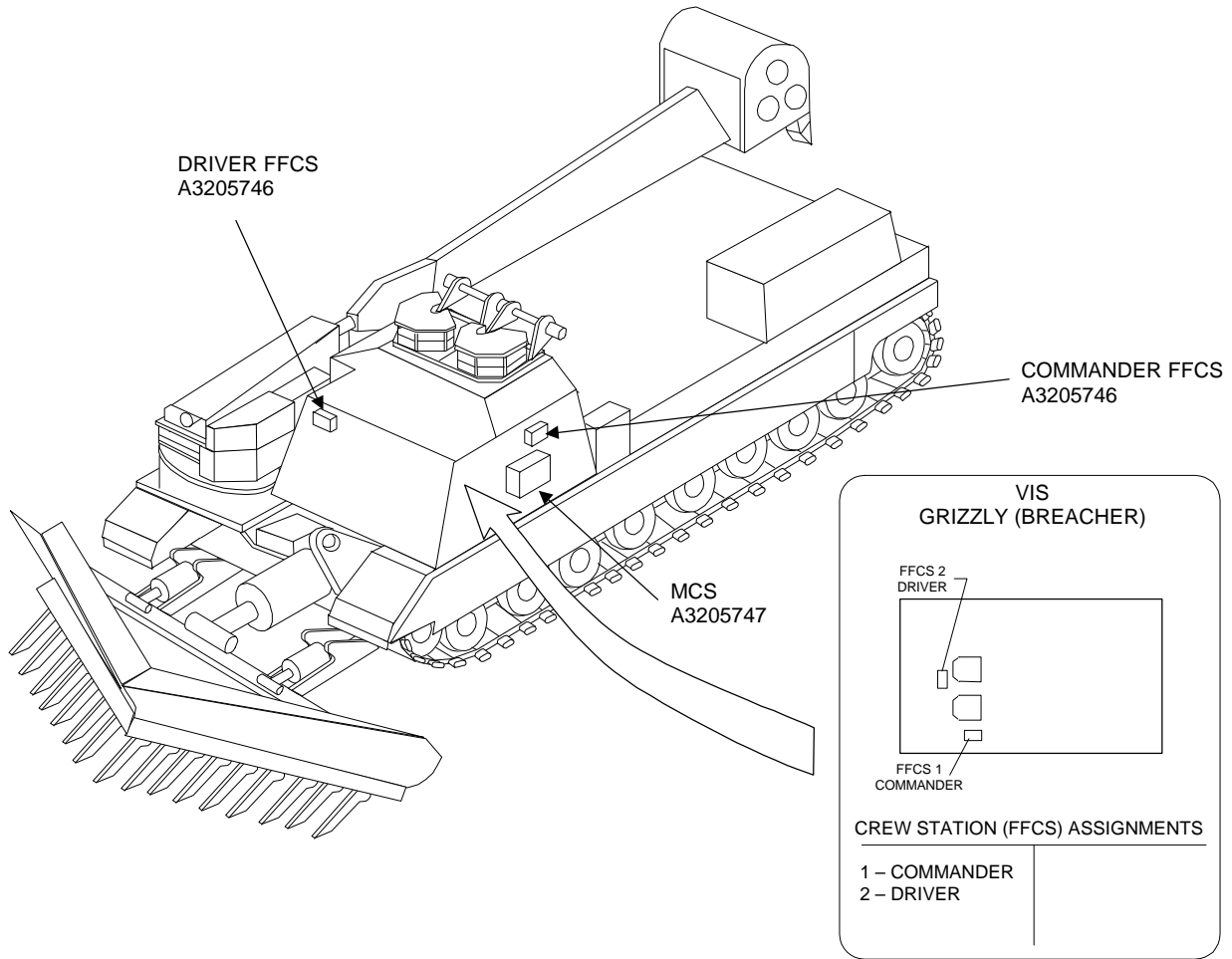
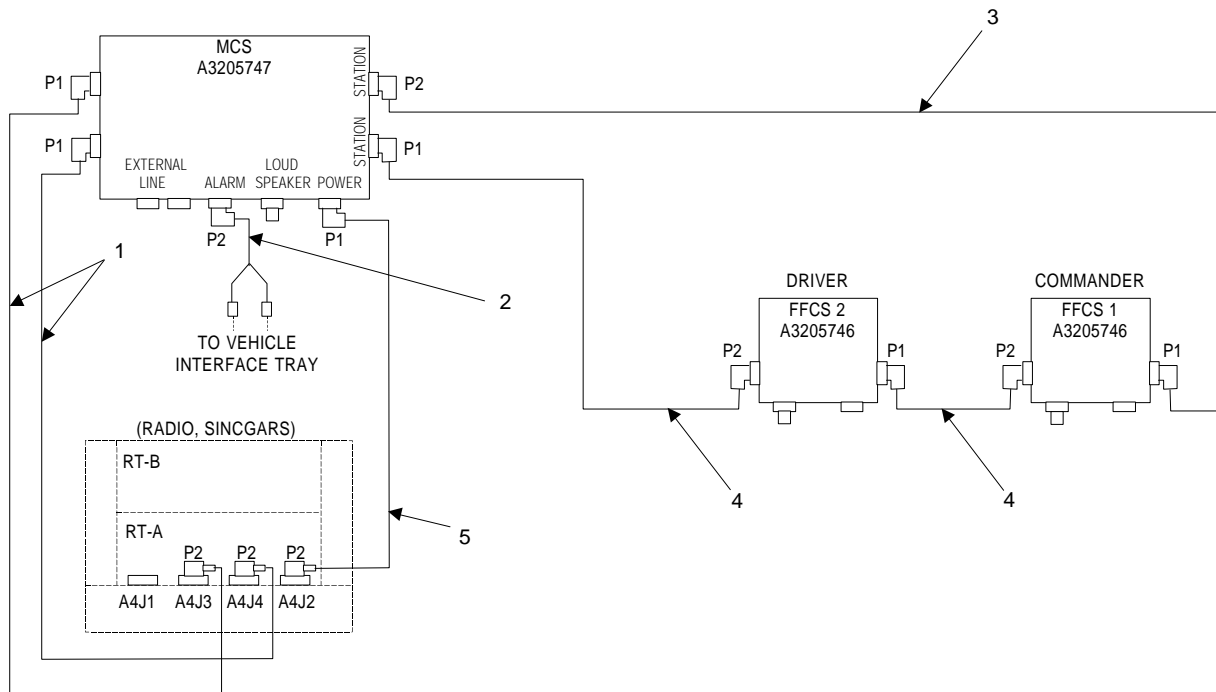

Figure 2-33. BREACHER Equipment Location Diagram



----- EXISTING COMPONENTS

CABLE PART NUMBERS FOR GRIZZLY (BREACHER)

- 1. A3206019-10 (RECEIVE/TRANSMIT)
- 2. A3207046 (SPECIAL PURPOSE)
- 3. A3206018-2 (HIGHWAY)
- 4. A3206018-16 (HIGHWAY)
- 5. A3206017-10 (POWER)

RING SEQUENCE FOR GRIZZLY (BREACHER)

FROM VIS BOX	CABLE	TO VIS BOX	CABLE
MCS (TOP CONN)	#3 (P2)	FFCS 1	#3 (P1)
FFCS 1	#4 (P2)	FFCS 2	#4 (P1)
FFCS 2	#4 (P2)	MCS (BOTTOM CONN)	#4 (P1)

Figure 2-34. BREACHER System Configuration Diagram

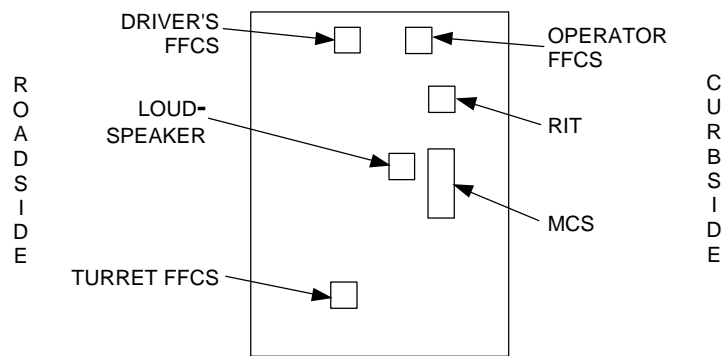
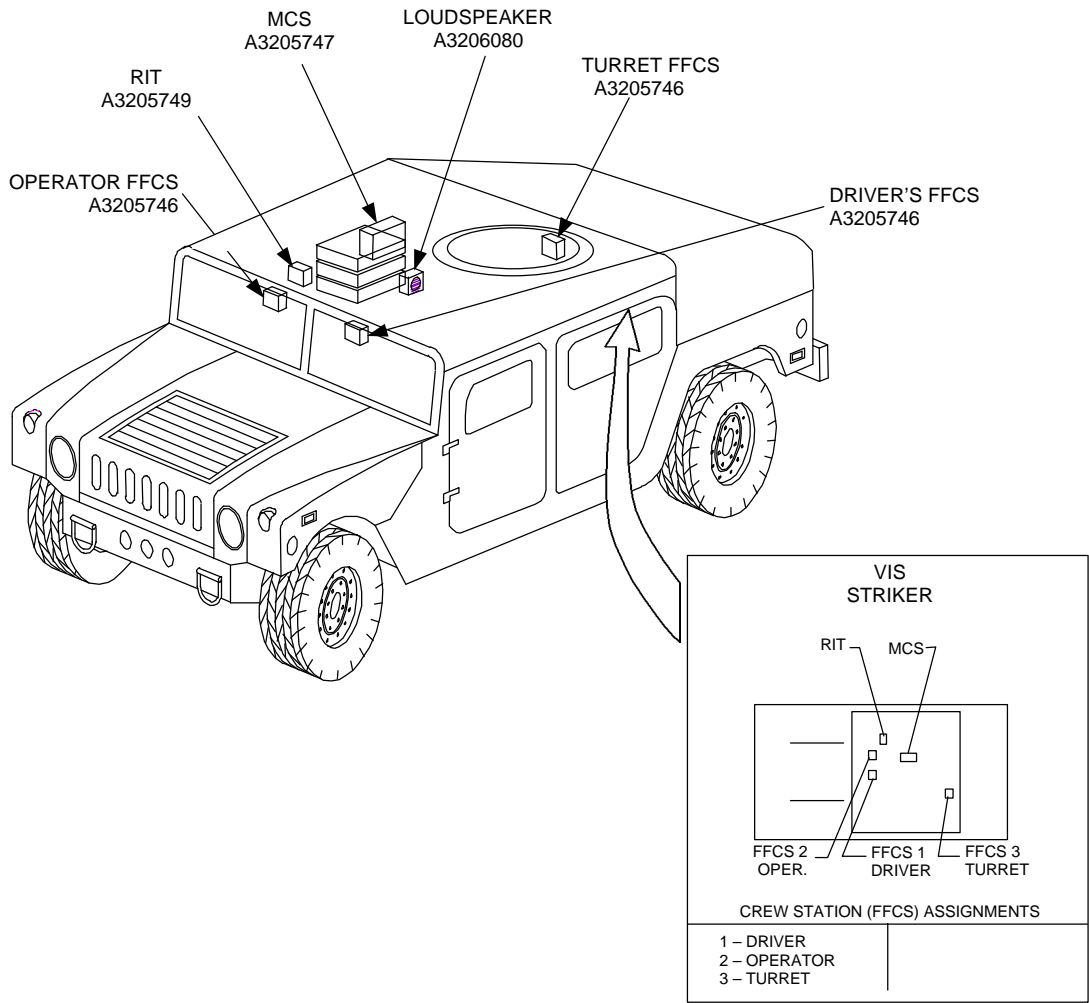
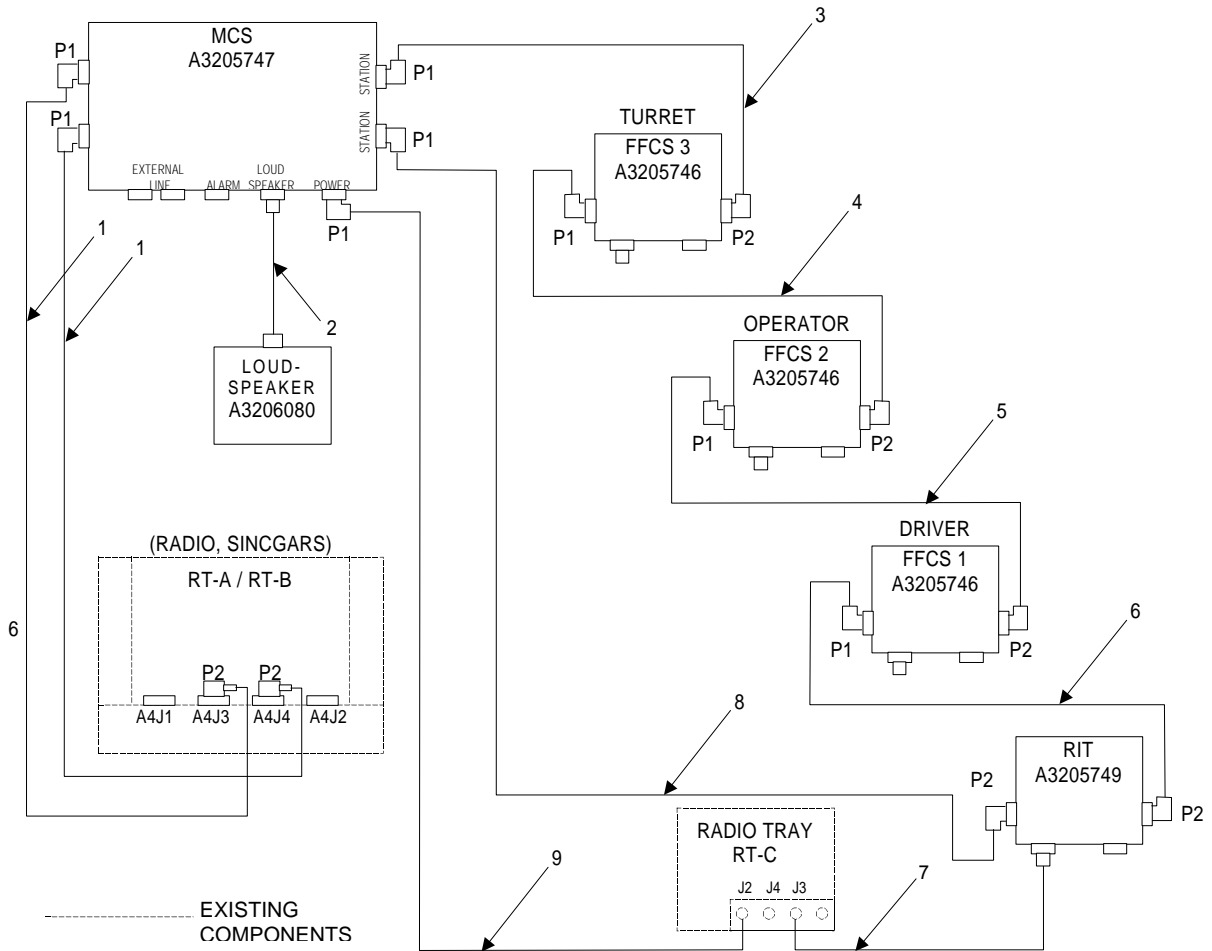

Figure 2-35. STRIKER Equipment Location Diagram



CABLE PART NUMBERS FOR STRIKER

- 1. A3206019-4 (RECEIVE/TRANSMIT)
- 2. A3206193-6 (LOUDSPEAKER)
- 3. A3206018-8 (HIGHWAY)
- 4. A3206018-16 (HIGHWAY)
- 5. A3206018-2 (HIGHWAY)
- 6. A3206018-7 (HIGHWAY)
- 7. A3206019-2 (RECEIVE/TRANSMIT)
- 8. A3206018-4 (HIGHWAY)
- 9. A3206017-5 (POWER)

RING SEQUENCE FOR STRIKER

FROM VIS BOX	CABLE	TO VIS BOX	CABLE
MCS (TOP CONN)	#3 (P1)	FFCS 3	#3 (P2)
FFCS 3	#4 (P1)	FFCS 2	#4 (P2)
FFCS 2	#5 (P1)	FFCS 1	#5 (P2)
FFCS 1	#6 (P1)	RIT	#6(P2)
RIT	#8 (P2)	MCS (BOT CONN)	#8 (P1)

Figure 2-36. STRIKER System Configuration Diagram

SECTION III FFCS AND RIT CREW STATION/RADIO SWITCH SETTING PROCEDURES

2.6. FFCS CREW STATION ADDRESS SWITCH SETTING PROCEDURES (FIG. 2-37.)

Perform the following procedure to change the FFCS Crew Station Address switch setting located on the bottom of the FFCS.

- a. Rotate switch cover screw counterclockwise and remove.
- b. Using a jeweler's screwdriver, rotate the adjustment screw counterclockwise, until stop is reached. This is the setting for Crew Station #1.
- c. Each click of the switch in a clockwise direction changes the address by one position. For example, with the switch in the full ccw position (Crew Station #1), turning the switch two clicks in a clockwise direction will set the FFCS to Crew Station #3.
- d. The address switch has 8 positions. Crew Station settings are numbered 1 through 6. Position 7 on the switch is the same as position 6. Position 8 on the switch is normally used for testing, however, if the MCS is not functioning correctly, e.g., loss of timing signal (sync pulse), but is supplying power to the rest of the system, setting the switch to position 8 will result in the FFCS putting out a timing signal like the MCS.
- e. When the correct Crew Station address has been set replace switch cover screw and hand tighten.

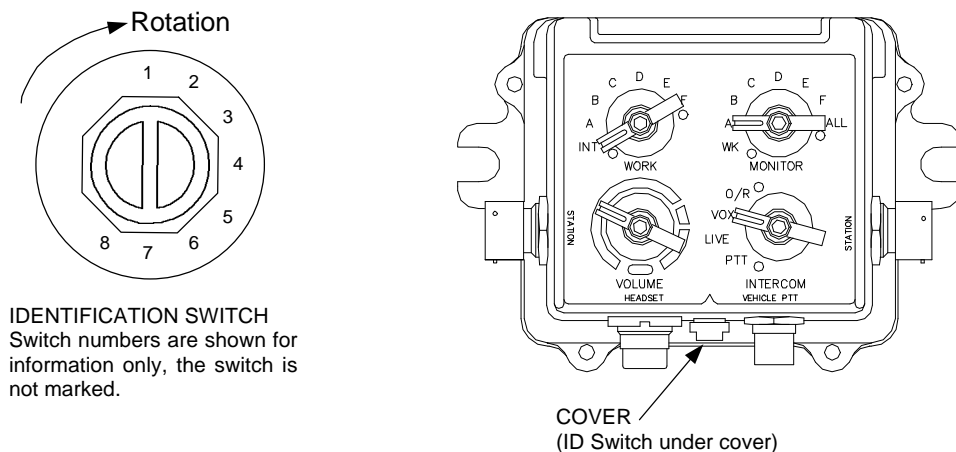

Figure 2-37. FFCS Crew Station Address Switch

2.7. RIT RADIO SELECTION SWITCH SETTING PROCEDURES (FIG. 2-38.)

Perform the following procedures to set the Radio Selection Switch on RIT.

NOTE

The following procedures can only be performed when the RIT is dismantled.

- a. Remove the switch protective cover from rear plate of RIT using a spanner wrench, and rotating counterclockwise.
- b. Using a jeweler's screwdriver turn switch counterclockwise to stop, this sets the RIT to Radio's C/D.
- c. Turning the switch clockwise one position sets the RIT to center position. This position is used for testing, however, if the MCS is not functioning correctly, e.g., loss of timing signal (sync pulse), but is supplying power to the rest of the system, setting the switch to this position will result in the RIT putting out a timing signal like the MCS.
- d. Turning the switch clockwise one more position sets the RIT to Radio E/F.
- e. When the correct Radio setting position for the RIT has been made, replace switch protective cover using spanner wrench and tighten.

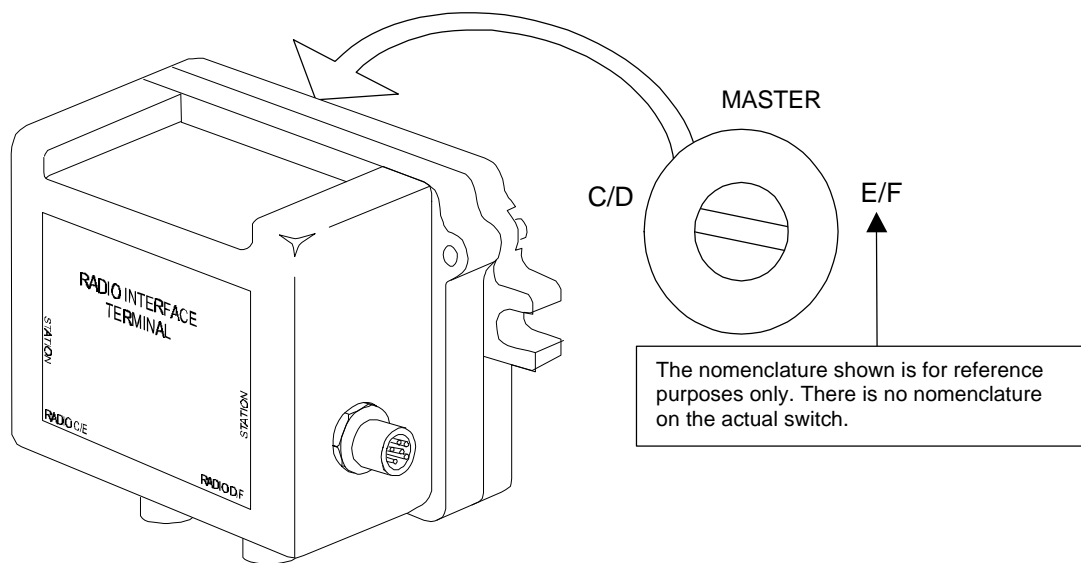

Figure 2-38. RIT Radio Selection Switch

SECTION IV SYSTEM TROUBLESHOOTING WITH NO ERROR SHOWN ON ALPHANUMERIC DISPLAY

CAUTION

BE SURE TO REMOVE POWER FROM THE MCS BEFORE DISCONNECTING OR REMOVING AND REPLACING COMPONENTS AND/OR CABLES.

2.8. TROUBLESHOOTING WITH NO ERROR MESSAGE DISPLAY

- a. General
The procedures in step b below troubleshoot faulty equipment in VIS not indicated on the MCS alphanumeric display. They apply whether trouble is in radio or intercom communication. If an error message is displayed, refer to Section V. See Table 2-2 for the troubleshooting flowchart(s) to correct the fault.
- b. Troubleshooting the system
Perform the following steps in sequence, to ensure accurate troubleshooting of the equipment: System Troubleshooting Chart, Table 2-2, lists symptoms of faults in priority order. Start with the lowest test number on Table 2-2 that resembles the current fault. If a test number is skipped, it is assumed that symptom has not occurred.

NOTE

Reference to “substitution of a VIS box with a known good one” in the troubleshooting flowcharts refers to properly configured (Section III) and operationally verified replacement equipment.

Table 2-2. System Troubleshooting Chart

Test Number	Symptom	Probable Causes	Corrective Measures
1	Vehicle master circuit breaker trips.	a. Defective MCS. b. Defective power cable assembly. c. Defective vehicle wiring.	See figure 2-39.
2	MCS alphanumeric display does not light when SYSTEM switch is in position other than OFF.	a. Power is turned off. b. Defective power cable assembly. c. System power fault. d. Defective MCS.	See figure 2-40.
3	MCS System Power Fault LED illuminates.	a. Defective MCS. b. Defective highway cable assembly. c. Defective FFCS/RIT/MOS.	See figure 2-41.

Table 2-2. System Troubleshooting Chart (continued)

Test Number	Symptom	Probable Causes	Corrective Measures
4	MCS ANR Power Fault LED illuminates.	a. Defective MCS. b. Defective highway cable assembly. c. Defective headset. d. Defective FFCS/MOS headset.	See figure 2-42.
5	MCS alphanumeric display does not change when SYSTEM switch is moved between positions P1, P2, P3, LS, or ALL.	Defective MCS.	Replace defective MCS.
6	MCS alphanumeric display shows incorrect or illegal characters.	Defective MCS.	Replace defective MCS.
7	Programming positions P1, P2, and P3 have changed without operator changing.	Defective MCS.	Replace defective MCS.
8	Radio can be keyed from an FFCS when MCS SYSTEM switch is in LISTENING SILENCE mode.	a. Defective RIT. b. Defective MCS.	See figure 2-43.
9	No radio communication (transmitting and/or receiving) at more than 1 FFCS but communication over intercom is still possible.	a. Defective radio. b. Defective radio cable assembly. c. Defective RIT. d. Defective MCS. e. Defective headset.	See figure 2-44.
10	Radio does not key from a specific FFCS but communication over intercom is still possible.	a. Defective bailout cable. b. Defective headset. c. Defective FFCS.	See figure 2-45.
11	Unable to communicate (transmitting and/or receiving) on intercom and radio at 2 or more crewstations.	Defective MCS.	Replace defective MCS.
12	Unable to communicate (transmitting and/or receiving) on intercom and radio from any 1 MOS or FFCS.	a. Defective bailout cable. b. Defective headset. c. Defective FFCS/MOS.	See figure 2-46.
13	Intercom continuously keyed.	a. Defective bailout cable. b. Defective headset. c. Defective vehicle PTT cable. d. Defective FFCS.	See figure 2-47.

Table 2-2. System Troubleshooting Chart (continued)

Test Number	Symptom	Probable Causes	Corrective Measures
14	FFCS operates incorrectly based on WORK, MONITOR, VOLUME, and/or INTERCOM switch settings.	Defective FFCS	Replace defective FFCS.
15	Field Lines not heard on intercom.	a. Field wire cable not properly connected. b. Defective field wire. c. Defective MCS.	See figure 2-48.
16	Intercom not heard at remote end of field lines when LINES switch is ON.	Defective MCS.	Replace defective MCS.
17	Vehicle alarms not heard on intercom.	a. Defective alarm generation equipment. b. Defective alarm cable. c. Defective MCS.	See figure 2-49.
18	No loudspeaker monitoring when LOUDSPEAKER switch ON MCS is set to INT or RADIO.	a. Defective loudspeaker cable. b. Defective loudspeaker. c. Defective MCS.	See figure 2-50.
19	Loudspeaker output heard when LOUDSPEAKER switch on the MCS is set to OFF.	Defective MCS.	Replace defective MCS.
20	Problem in headset.	a. Defective earcup assemblies. b. Defective microphone assembly.	See figure 2-51.

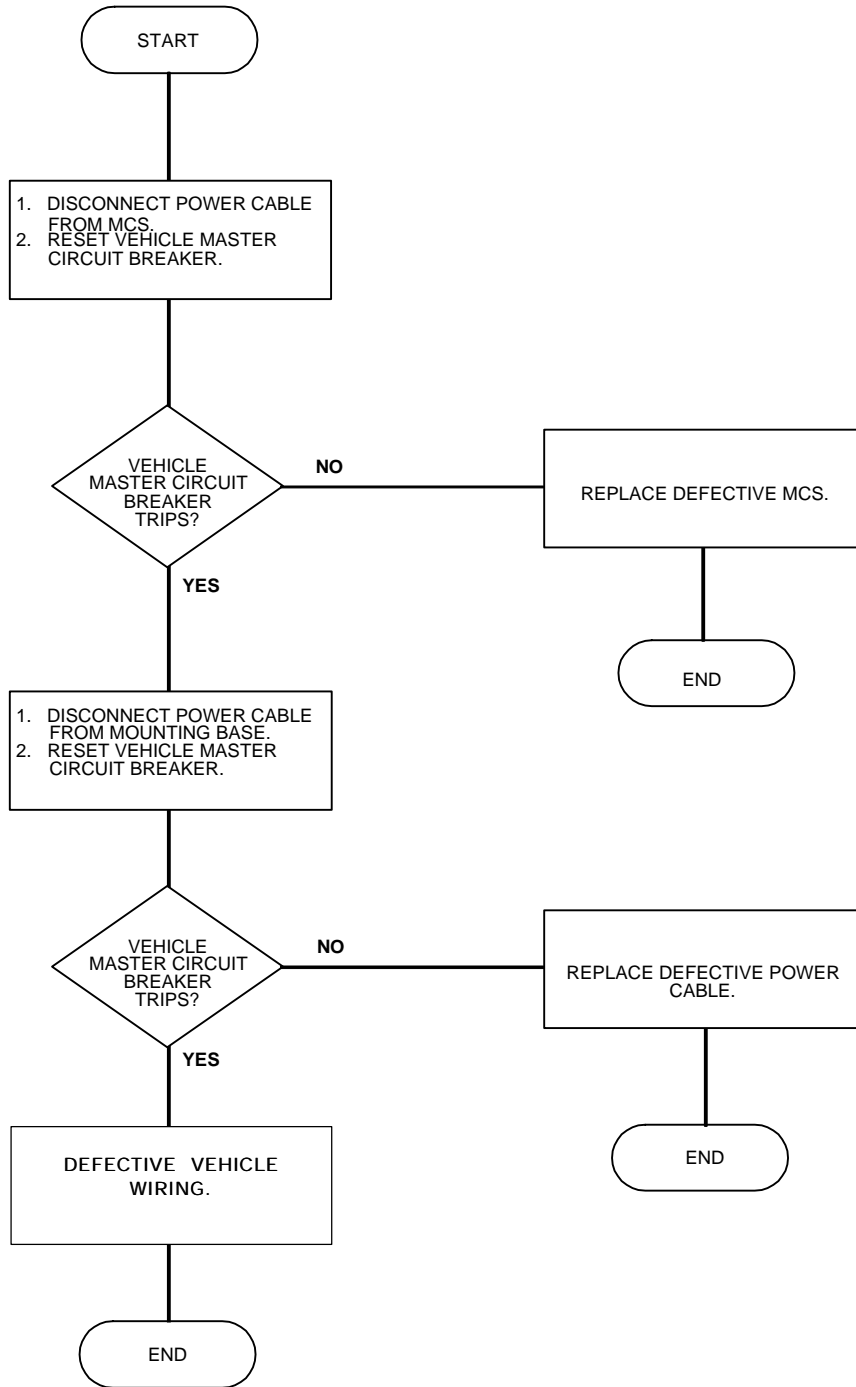

Figure 2-39. Tripped vehicle master circuit breaker Flowchart

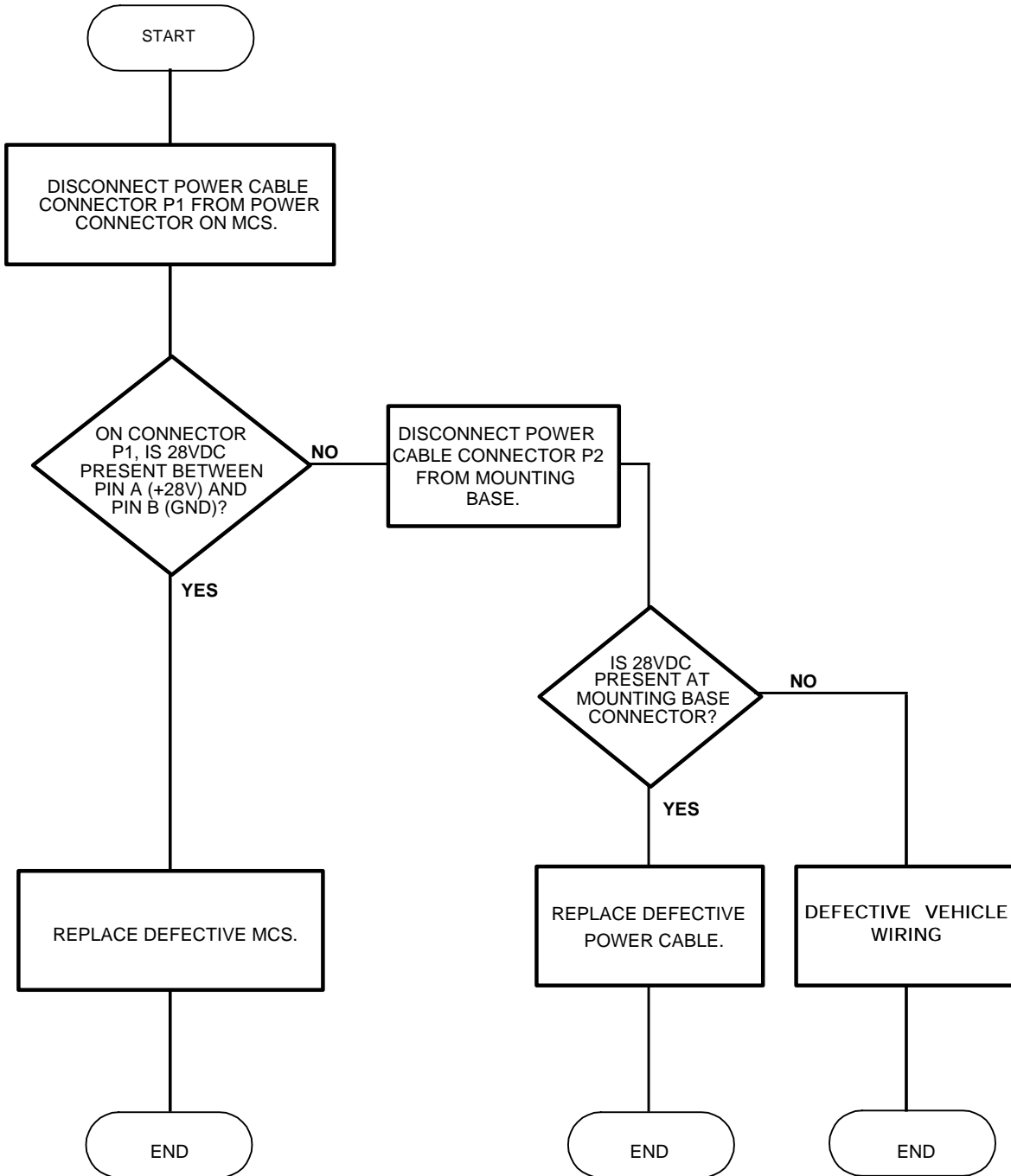

Figure 2-40. MCS alphanumeric display Flowchart

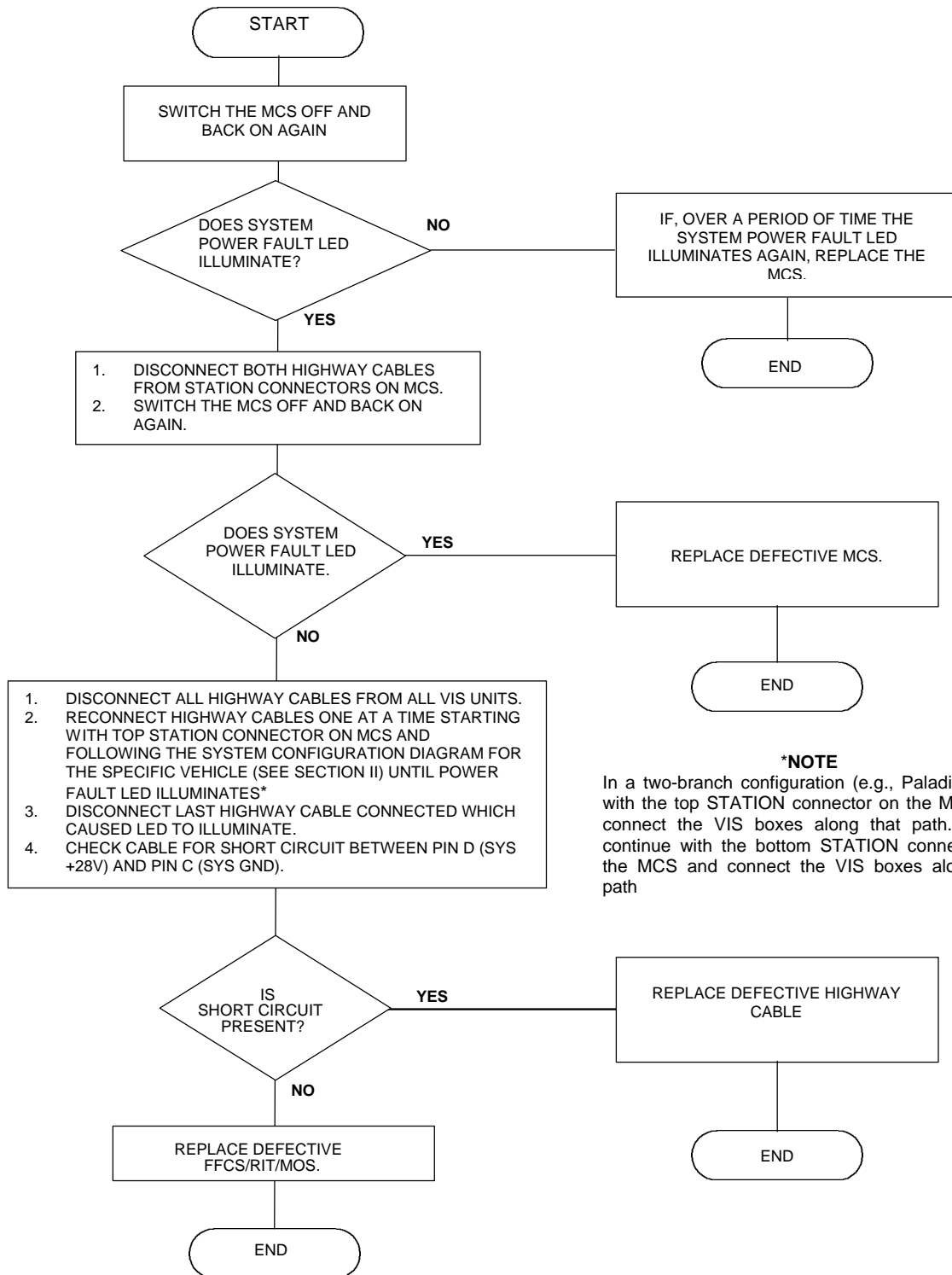

Figure 2-41. System power fault LED Flowchart

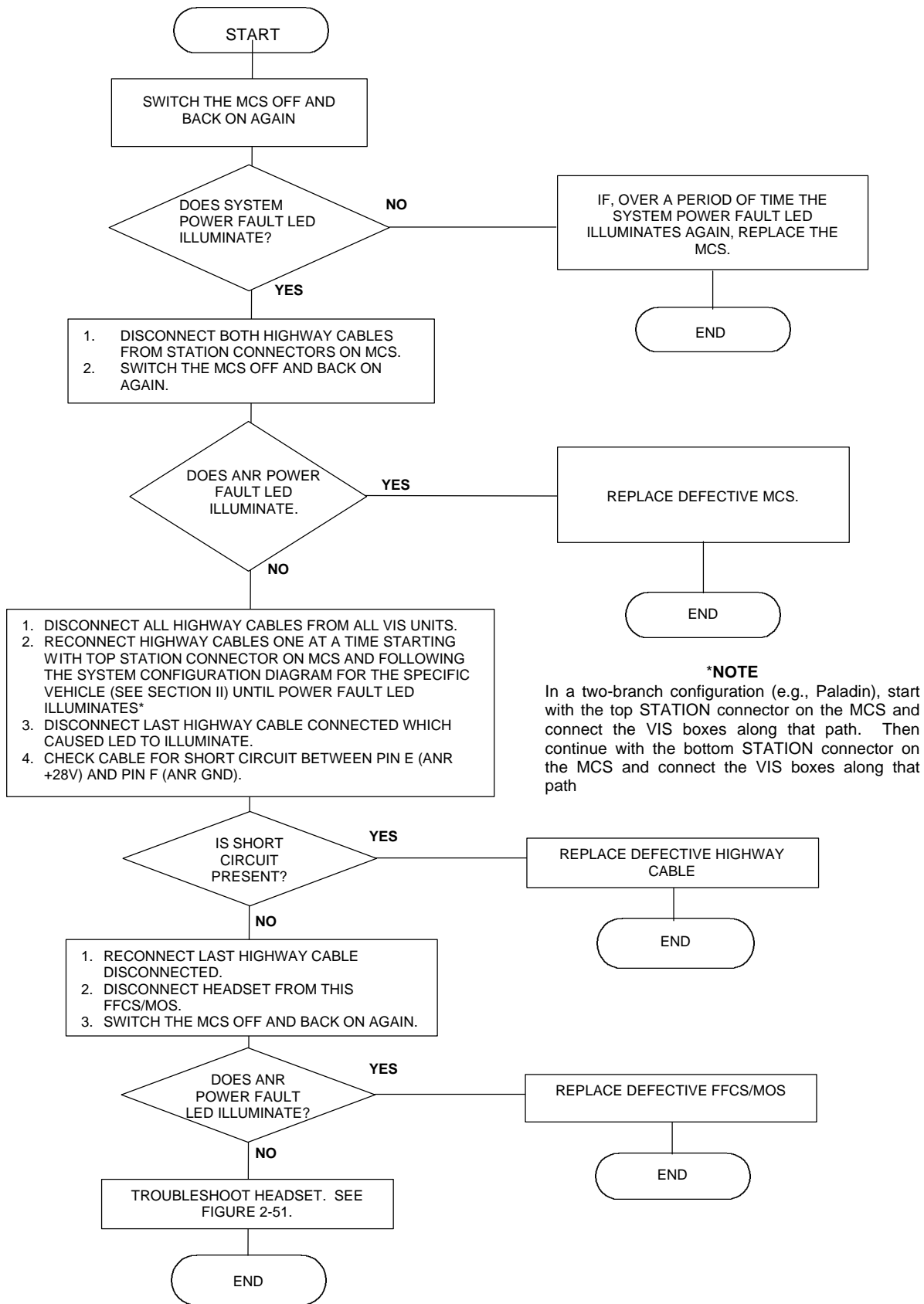

Figure 2-42. ANR power fault LED Flowchart

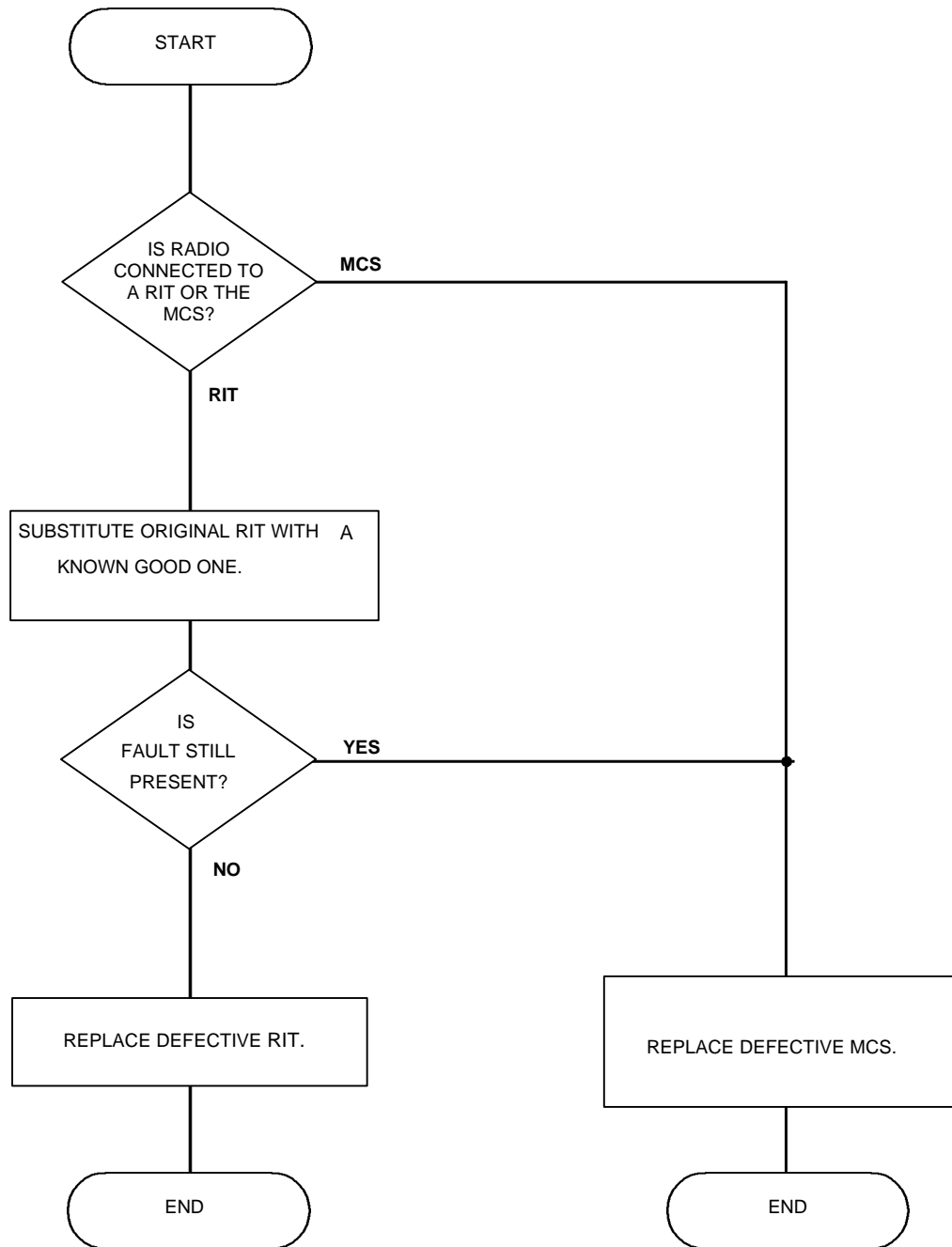

Figure 2-43. Radio can be keyed from an FFCS when MCS SYSTEM switch is in LS mode
Flowchart

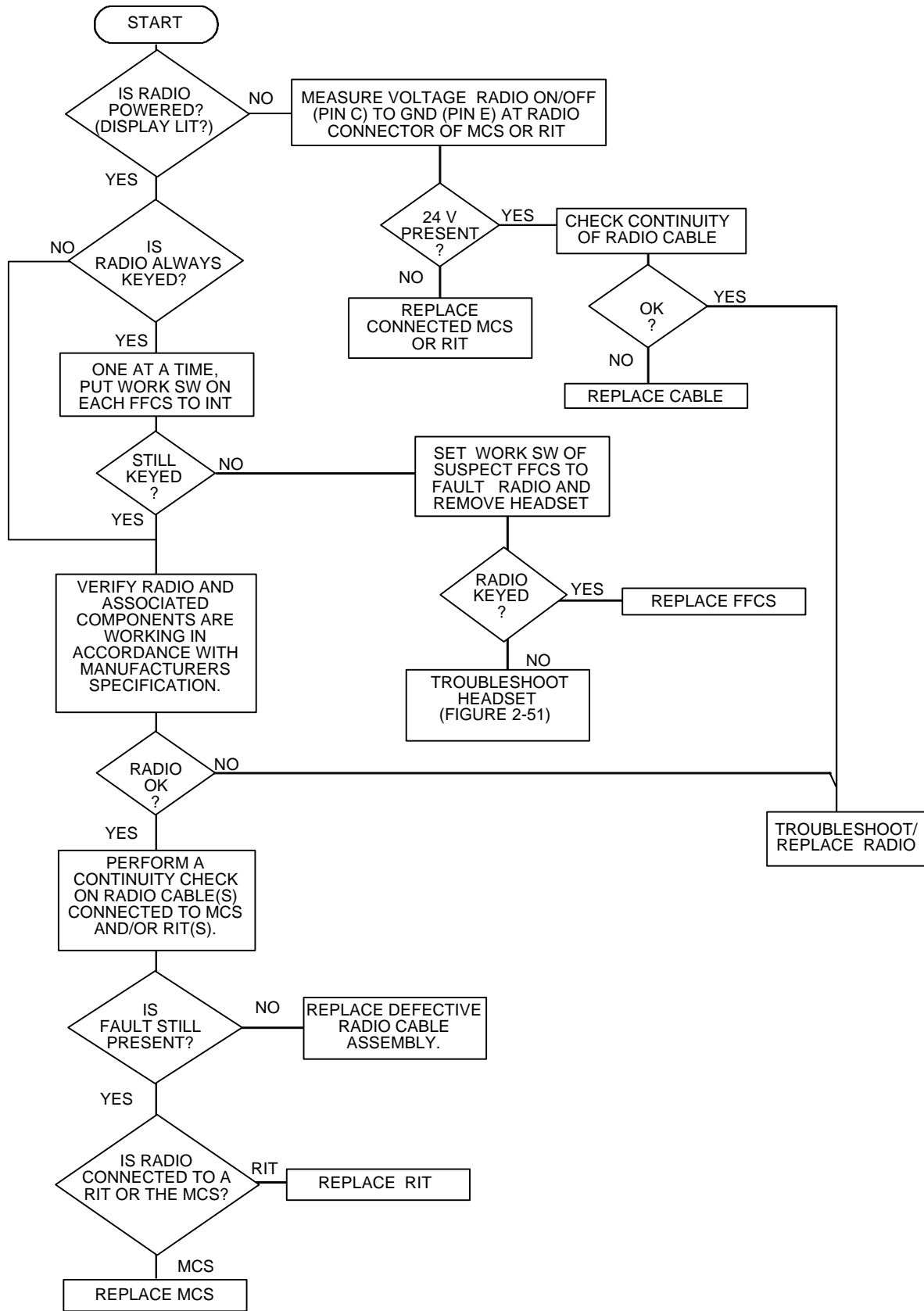

Figure 2-44. No communication capability on a radio at more than 1 FFCS but communication over intercom is still possible Flowchart

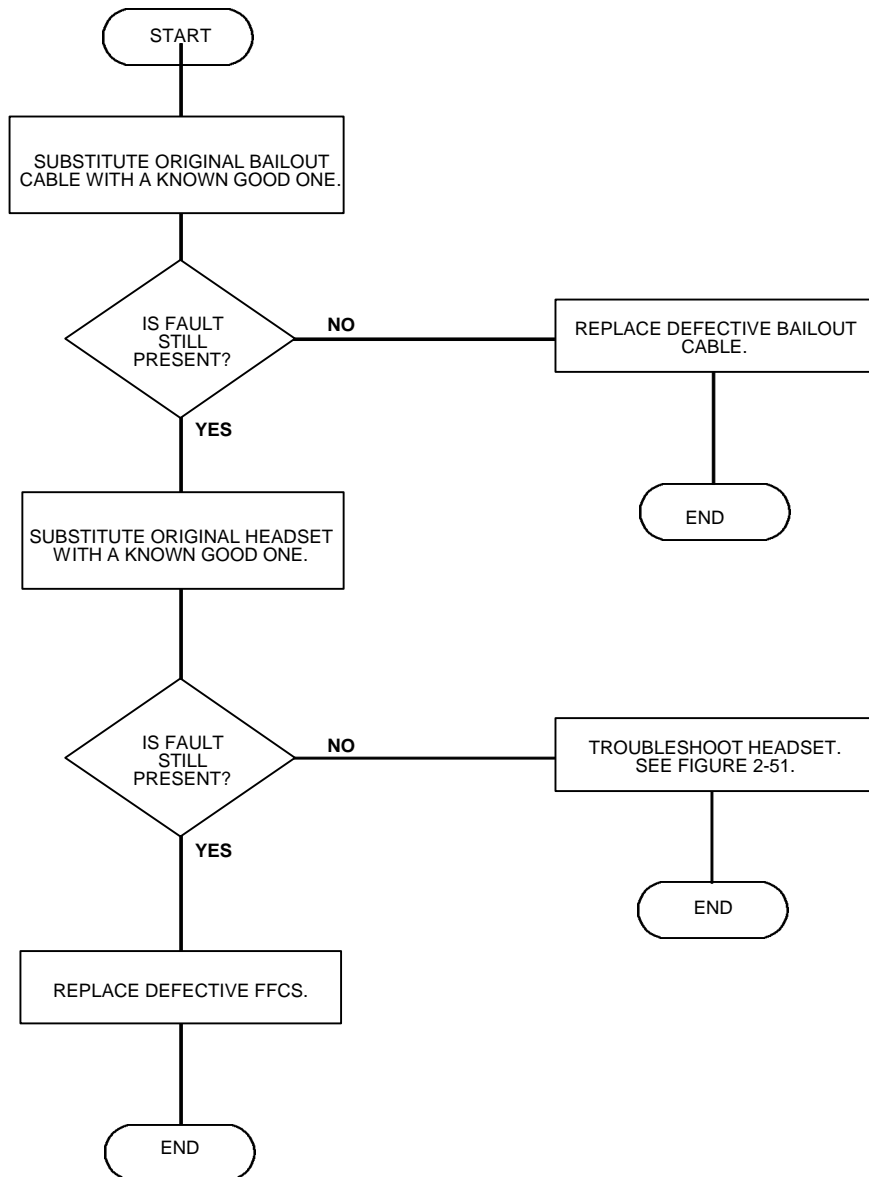

Figure 2-45. Radio does not key from a specific FFCS, but communication over intercom is still possible Flowchart

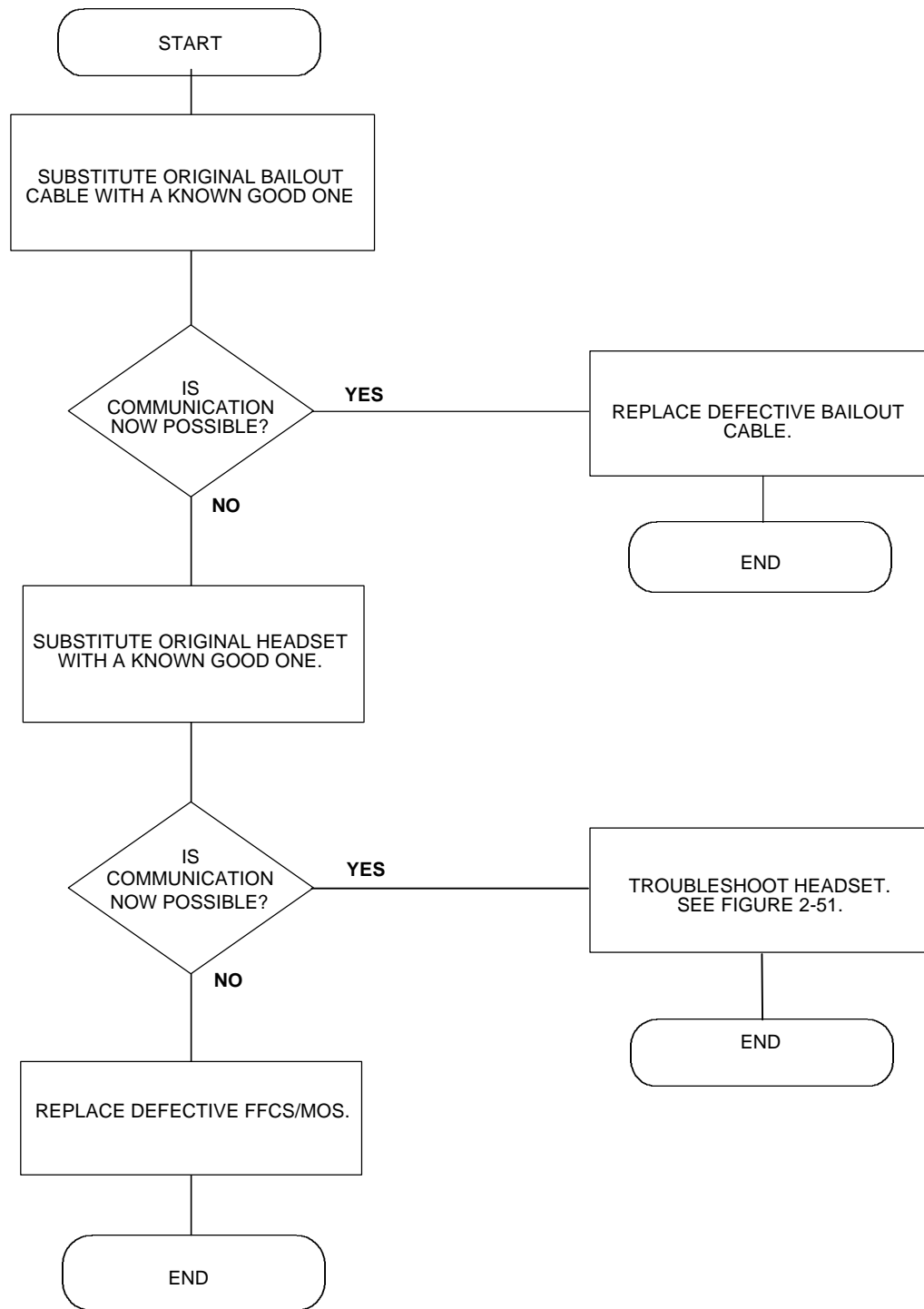

Figure 2-46. Unable to communicate on intercom and radio from any 1 MOS or FFCS Flowchart

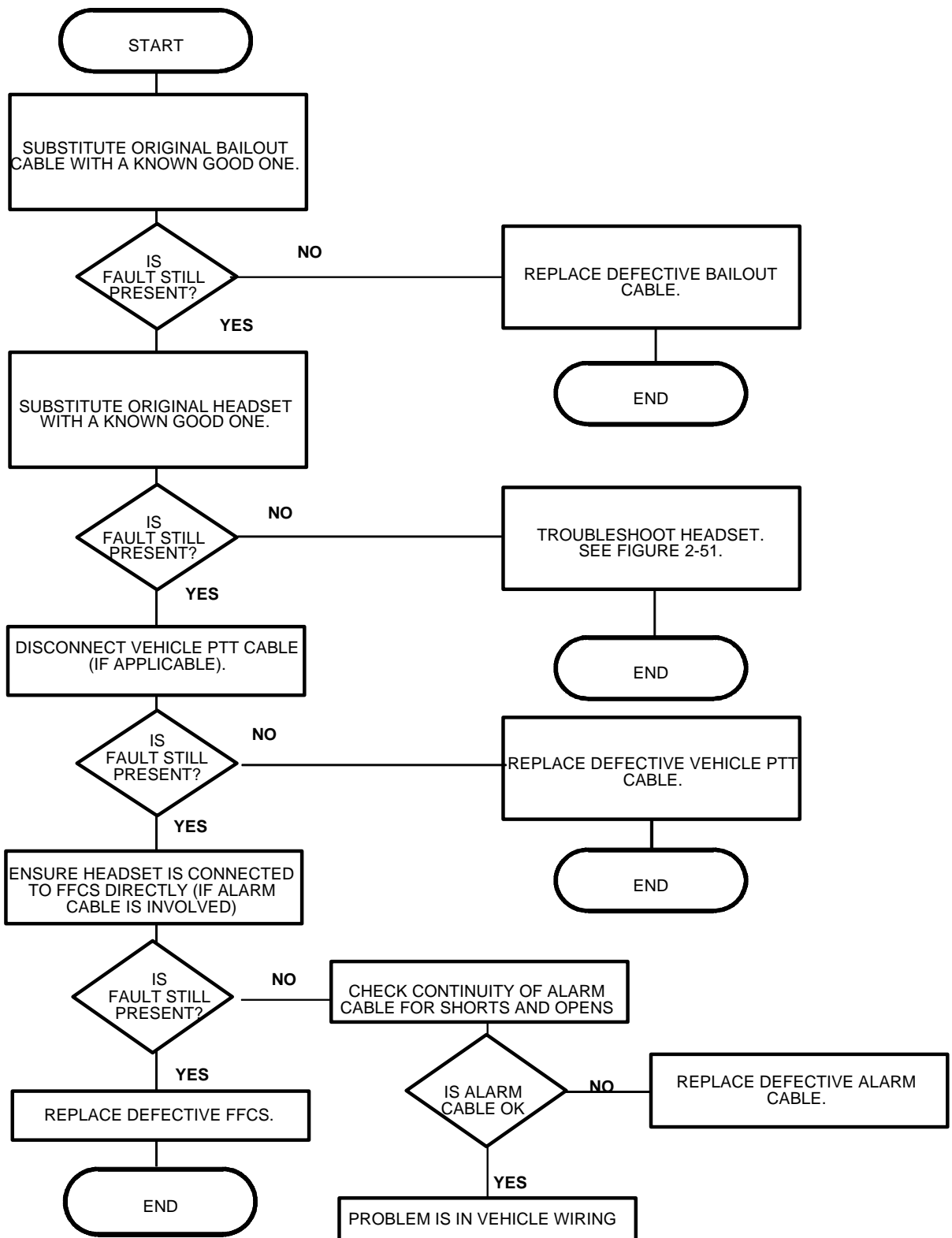

Figure 2-47. Intercom always keyed Flowchart

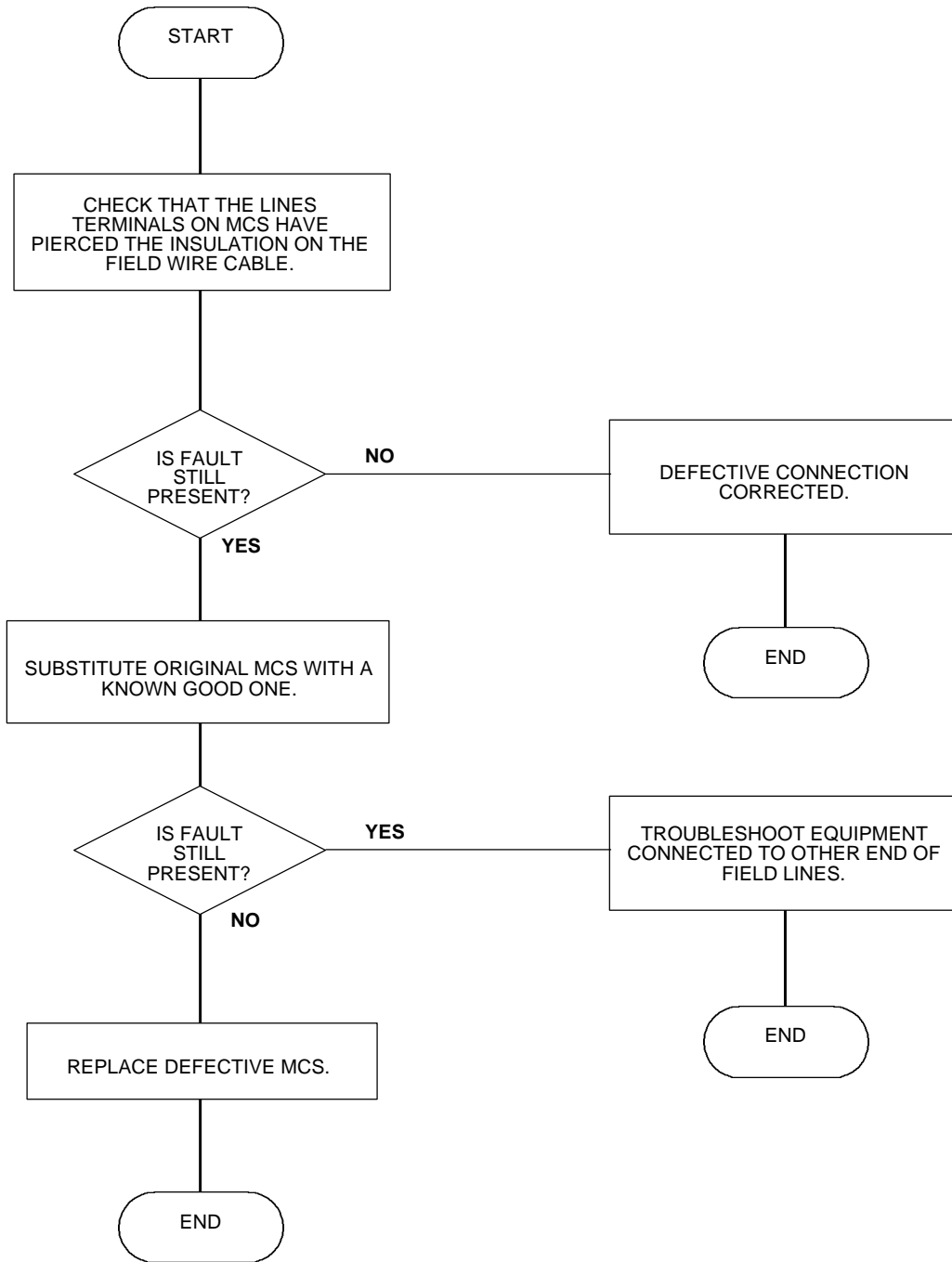

Figure 2-48. Field lines not heard on intercom Flowchart

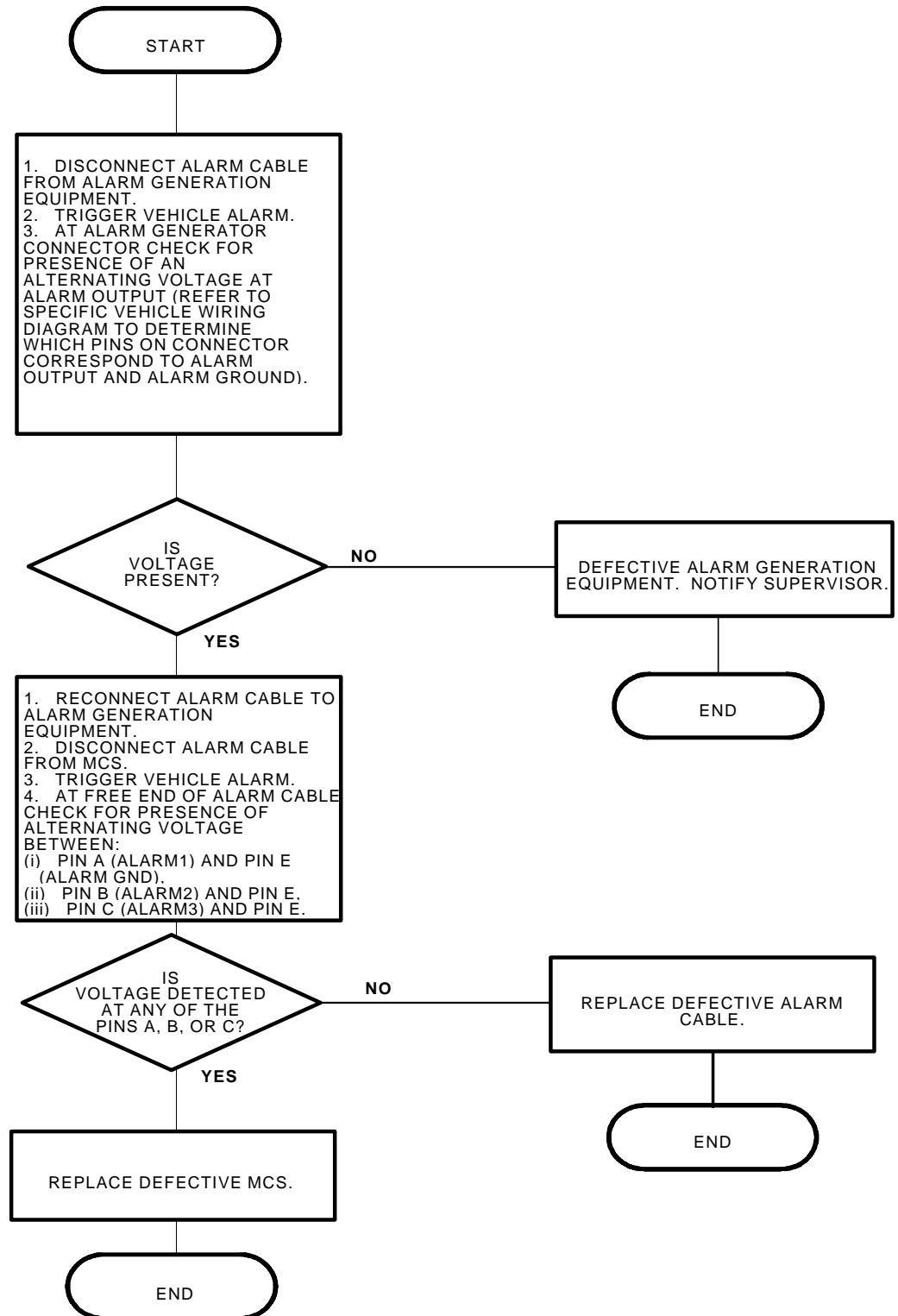

Figure 2-49. Vehicle alarms not heard on intercom Flowchart

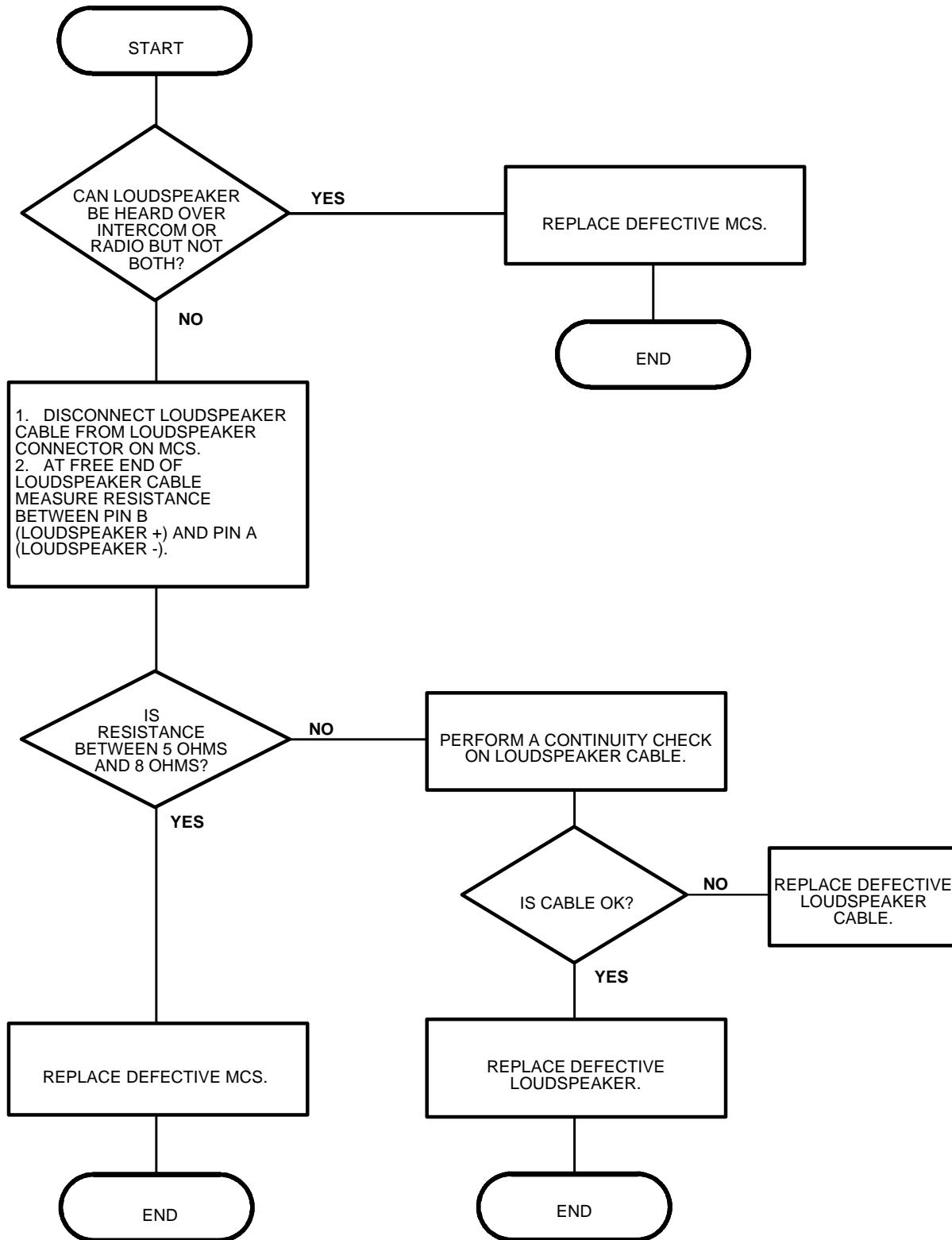

Figure 2-50. No loudspeaker monitoring when LOUDSPEAKER switch is set to INT or RADIO Flowchart

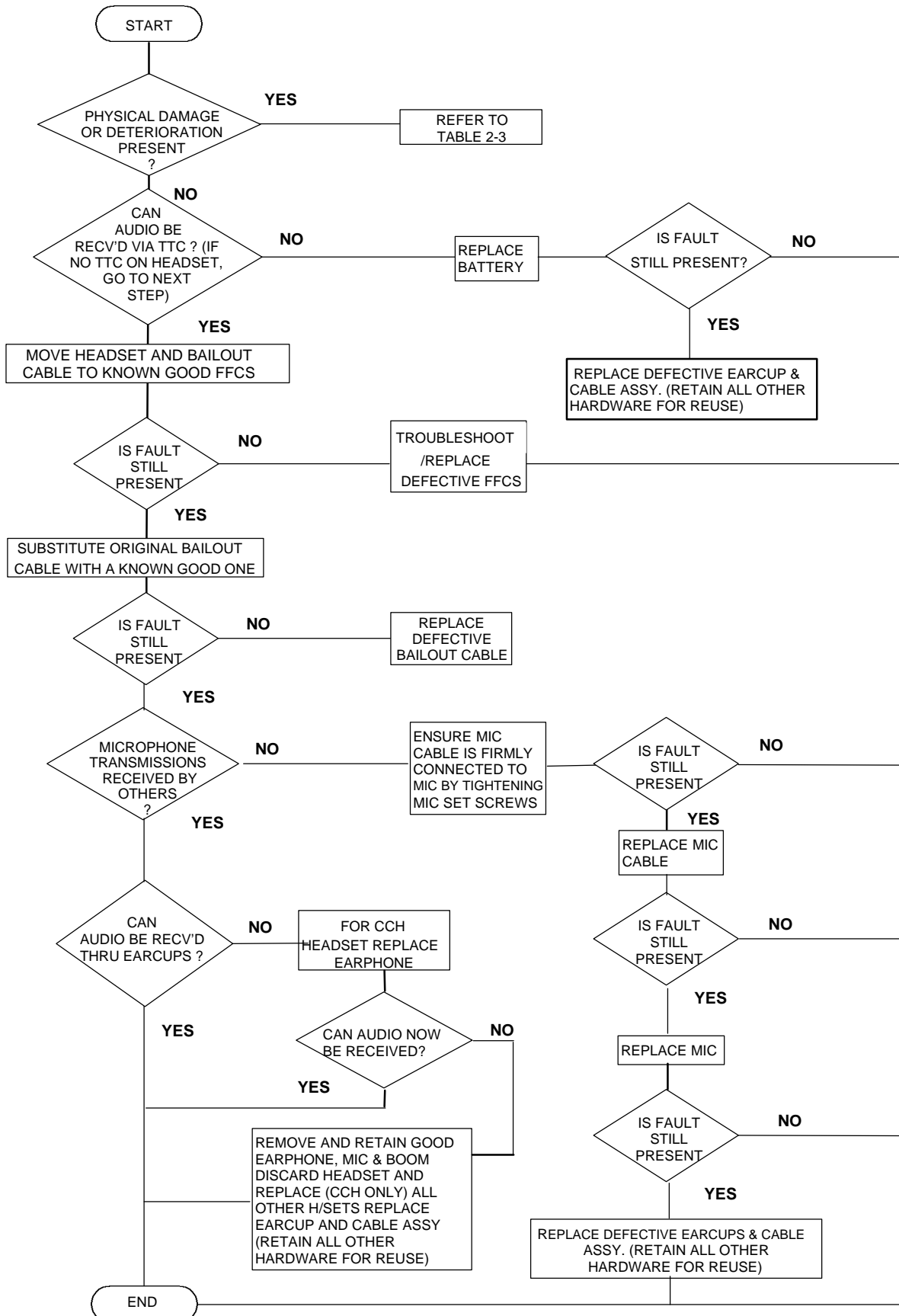

Figure 2-51. Headset fault Flowchart

Table 2-3. Headset Inspection

Component	Condition	Corrective Measures
1. Earcup Assembly	Check for cracks and other visible damage to the housing.	Replace earcup assembly. Refer to applicable headset removal and replacement procedure in Chapter 3.
2. Ear Seals	Check for visible cuts. Check that uniform pressure does not cause bottoming against earcup.	Replace ear cushions. Refer to applicable headset removal and replacement procedure in Chapter 3.
3. Foam or Cloth Within Earseals	Check for tears, powdery, or brittle condition, excessively dirty.	Refer to applicable headset removal and replacement procedure in Chapter 3.
4. Cables	Check for cuts, kinks, or frayed area on cable.	Refer to applicable headset removal and replacement procedure in Chapter 3.
5. Connectors	Check for dents or other physical damage; Corrosion buildup.	Refer to applicable headset removal and replacement procedure in Chapter 3.
6. Battery Compartment	Check for leakage, dents, corrosion buildup or other physical damage.	Refer to applicable battery removal and replacement procedure in Chapter 3.
7. Liner Inserts	Check for tears, powdery, or brittle condition, excessively dirty.	Refer to applicable liner insert removal and replacement procedure in Chapter 3.
8. Microphone, Boom, and Cable Assembly	Check for visible damage to microphone assembly (including piece parts) or connector(s).	Refer to applicable microphone, boom, and cable assembly removal and replacement procedure in Chapter 3.

SECTION V SYSTEM TROUBLESHOOTING WITH ERROR SHOWN ON ALPHANUMERIC DISPLAY

CAUTION

BE SURE TO REMOVE POWER FROM THE MCS BEFORE REMOVING OR REPLACING COMPONENTS AND/OR CABLES.

2.9. TROUBLESHOOTING WITH ALPHANUMERIC ERROR DISPLAY

a. General

The procedures in step b below troubleshoot faulty equipment in VIS with an error message (s) displayed on the MCS alphanumeric display. They apply whether trouble is in radio or intercom communication. For vehicles in a ring configuration, refer to Table 2-4. For vehicles in a two-branch configuration, refer to Table 2-5.

NOTE

Ensure that Para. 2.3. "Equipment Inspections/Checks/Guidelines" has been followed prior to beginning any troubleshooting procedures using Tables 2-4 or 2-5.

b. Troubleshooting the system

Perform the following steps in sequence to ensure accurate troubleshooting of the equipment.

1. Determine whether the vehicle has a ring or two-branch configuration.
2. Go to appropriate Table, 2-4 or 2-5.
3. Examine the "MCS Alphanumeric Display" column to find the error message that matches the one on the MCS display, while at the same time examine the "Error Description" column to correctly identify the corresponding problem.
4. Perform the action required as stated in the corresponding "Corrective Measures" column.

NOTE

Reference to "substitution of a VIS box with a known good one" in the troubleshooting flowcharts refers to properly configured (Section III) and operationally verified replacement equipment.

Table 2-4. MCS Alphanumeric Error Messages, Ring Configuration

MCS ALPHANUMERIC DISPLAY	ERROR DESCRIPTION	CORRECTIVE MEASURE
"err2"	MCS cannot store radio access data in program memory.	<ol style="list-style-type: none"> 1. Recycle power on MCS. 2. If message still appears, replace defective MCS.
Any one of the following: "A u" through "F u" or Any one of the following pairs "Au/Bu", "Cu/Du", or "Eu/Fu"	MCS not receiving acknowledgment of signal from MCS radio channels A and/or B or from RITs for radio channels C, and D, or E, and F.	<ol style="list-style-type: none"> 1. Recycle power on MCS. 2. If "C u", "D u", "E u", "F u", "Cu, Du", or "Eu, Fu" is displayed, replace defective RIT. 3. If "A u", "B u", or "Au, Bu" is displayed, replace defective MCS.
Single "X u" or "X u Y c" Where X is the numbered address setting of the FFCS and Y is either the numbered address setting of another FFCS or the alphabetic designation of a radio interface.	MCS not receiving acknowledgment of signal from FFCS "X".	<ol style="list-style-type: none"> 1. Recycle power on MCS. 2. If message "Xu" appears, replace defective FFCS "X".
"X c" Where X is the numbered address setting of the FFCS	MCS previously displayed "X u" from FFCS "X" which now acknowledges the MCS signal.	<ol style="list-style-type: none"> 1. Recycle power on MCS. 2. If fault message appears, replace defective FFCS "X".
"r u"	Ring is unconnected.	<ol style="list-style-type: none"> 1. Recycle power on MCS. 2. If message still appears, perform ring unconnected flowchart, figure 2-52.
"X u" and "r u" Where X is the numbered address setting of the FFCS	MCS not receiving acknowledgment of signal from FFCS "X" and ring is unconnected.	<ol style="list-style-type: none"> 1. Recycle power on MCS. 2. If message still appears, replace defective FFCS "X".
Multiple "X u" messages and "ru" Where X is the numbered address setting of the FFCSs and/or radio channel letters	MCS not receiving acknowledgment signals from FFCSs "X" and/or RITs, and ring is unconnected.	<ol style="list-style-type: none"> 1. Recycle power on MCS. 2. If message still appears, replace defective MCS.
Multiple "X u" messages Where X is the numbered address setting of the FFCSs and/or radio channel letters	MCS not receiving acknowledgment signals from FFCSs "X" and/or RITs.	<ol style="list-style-type: none"> 1. Recycle power on MCS. 2. If message still appears, perform multiple unconnected FFCSs/RITs flowchart, figure 2-53.

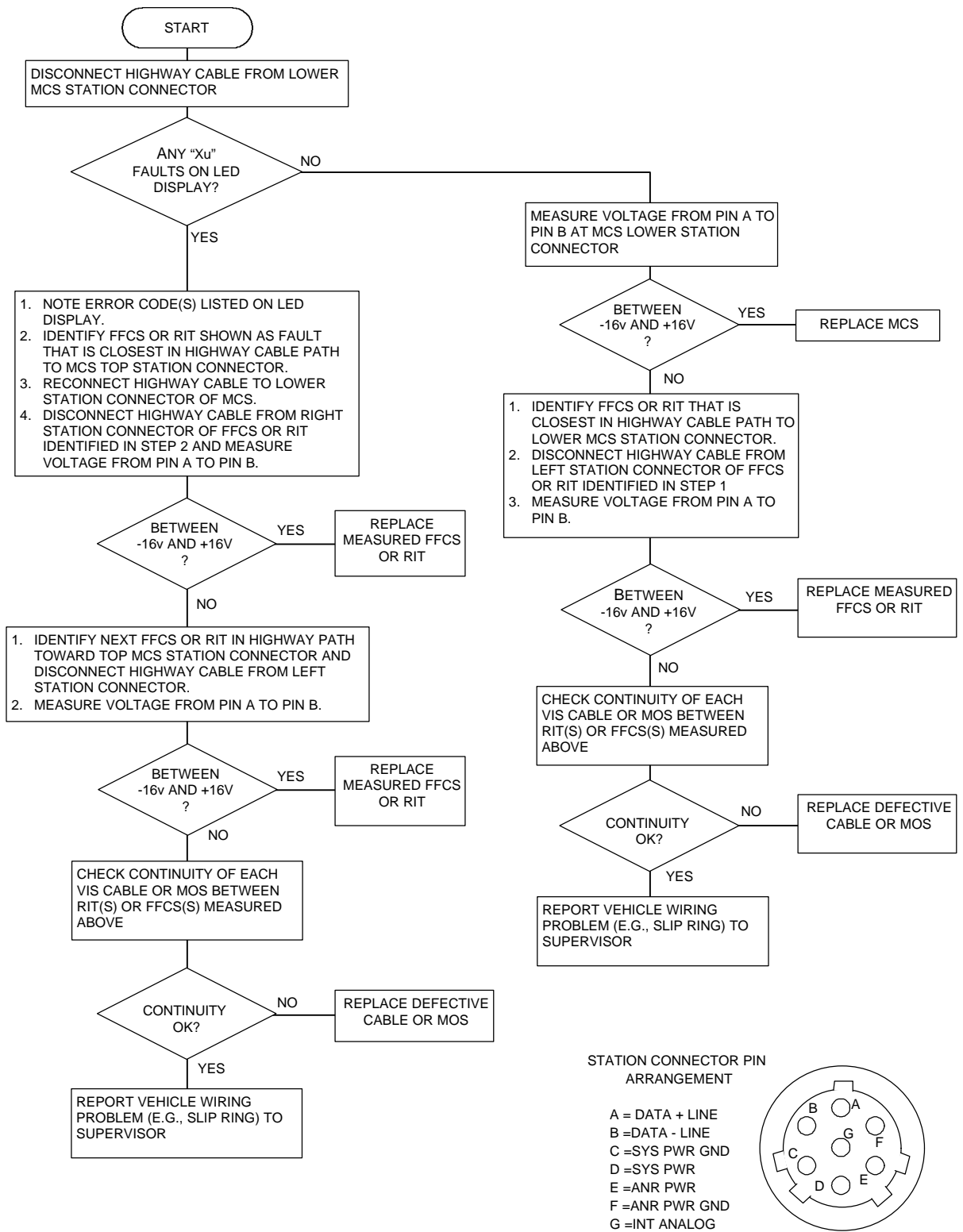

STATION CONNECTOR PIN ARRANGEMENT

- A = DATA + LINE
- B = DATA - LINE
- C = SYS PWR GND
- D = SYS PWR
- E = ANR PWR
- F = ANR PWR GND
- G = INT ANALOG

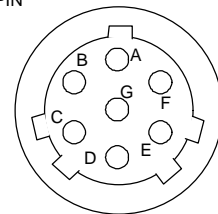

Figure 2-52. Ring Unconnected Flowchart

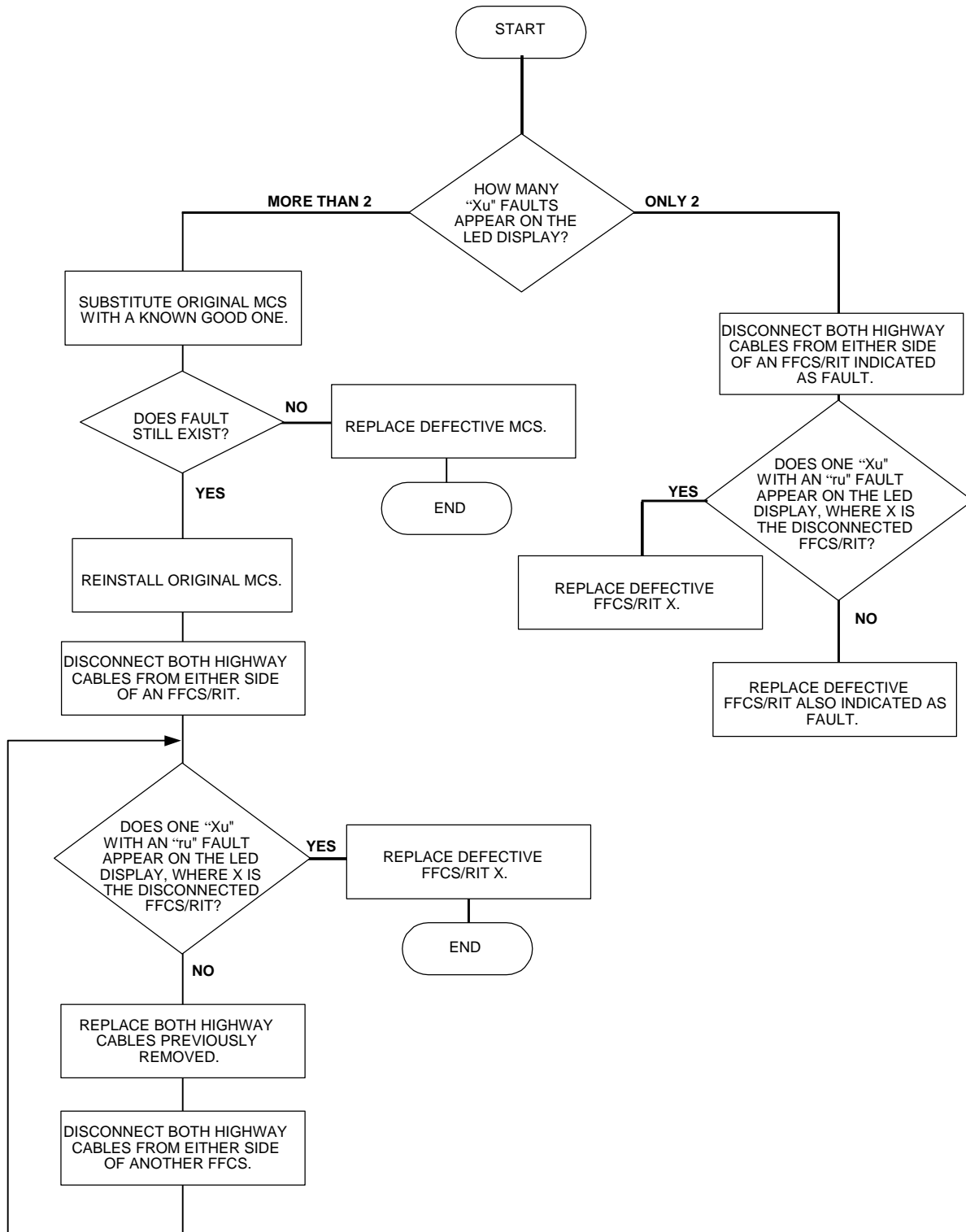

Figure 2-53. Multiple Unconnected FFCSs/RITs Flowchart

Table 2-5. MCS Alphanumeric Error Messages, Two-Branch Configuration

MCS ALPHANUMERIC DISPLAY	ERROR DESCRIPTION	CORRECTIVE MEASURE
"err2"	MCS cannot store radio access data in program memory.	<ol style="list-style-type: none"> 1. Recycle power on MCS. 2. If message still appears, replace defective MCS.
<p>One of the following: "A u", "B u" or "Au, Bu"</p>	MCS not receiving acknowledgment of signal from MCS radio channels A and/or B.	<ol style="list-style-type: none"> 1. Recycle power on MCS. 2. If fault message appears, replace defective MCS.
<p>"X u" Where X is the alphabetic designation of a single radio channel of a RIT interfacing two radios</p>	MCS not receiving acknowledgment from single channel in RIT	<ol style="list-style-type: none"> 1. Recycle power on MCS. 2. If fault message appears, replace defective RIT.
<p>Single "X u", "C u, D u", or "E u, F u" or One of Above Plus "Yc" Where X is the numbered address setting of the FFCS and Y is either the numbered address setting of another FFCS or the alphabetic designation of a radio interface.</p>	MCS not receiving acknowledgment of signal from FFCS "X" or indicated RIT.	<ol style="list-style-type: none"> 1. Recycle power on MCS. 2. If error message appears, refer to Figure 2-54.
<p>"X c" Where X is the numbered address setting of the FFCS</p>	MCS previously displayed "X u" from FFCS "X" which now acknowledges the MCS signal.	<ol style="list-style-type: none"> 1. Recycle power on MCS. 2. If fault message appears, replace defective FFCS "X".
<p>Multiple "X u" messages Where X is the numbered address setting of the FFCSs and/or radio channel letters</p>	MCS not receiving acknowledgment signals from FFCSs "X" and/or RITs.	<ol style="list-style-type: none"> 1. Recycle power on MCS. 2. If message still appears, perform multiple unconnected FFCSs/RITs flowchart, figure 2-55.

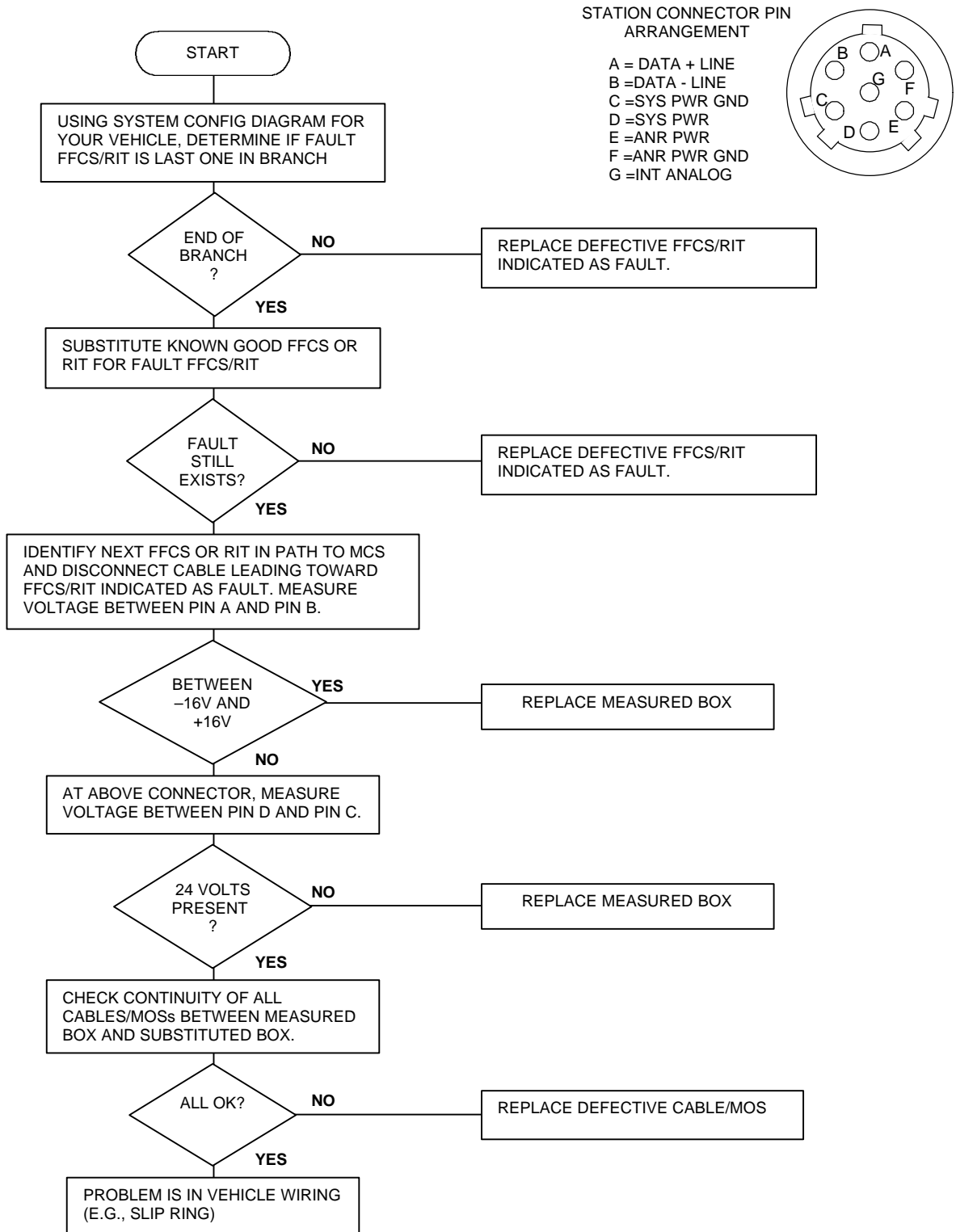

Figure 2-54. SINGLE “Xu” or Both-RIT-Channels Message For Two-Branch Configuration Flowchart

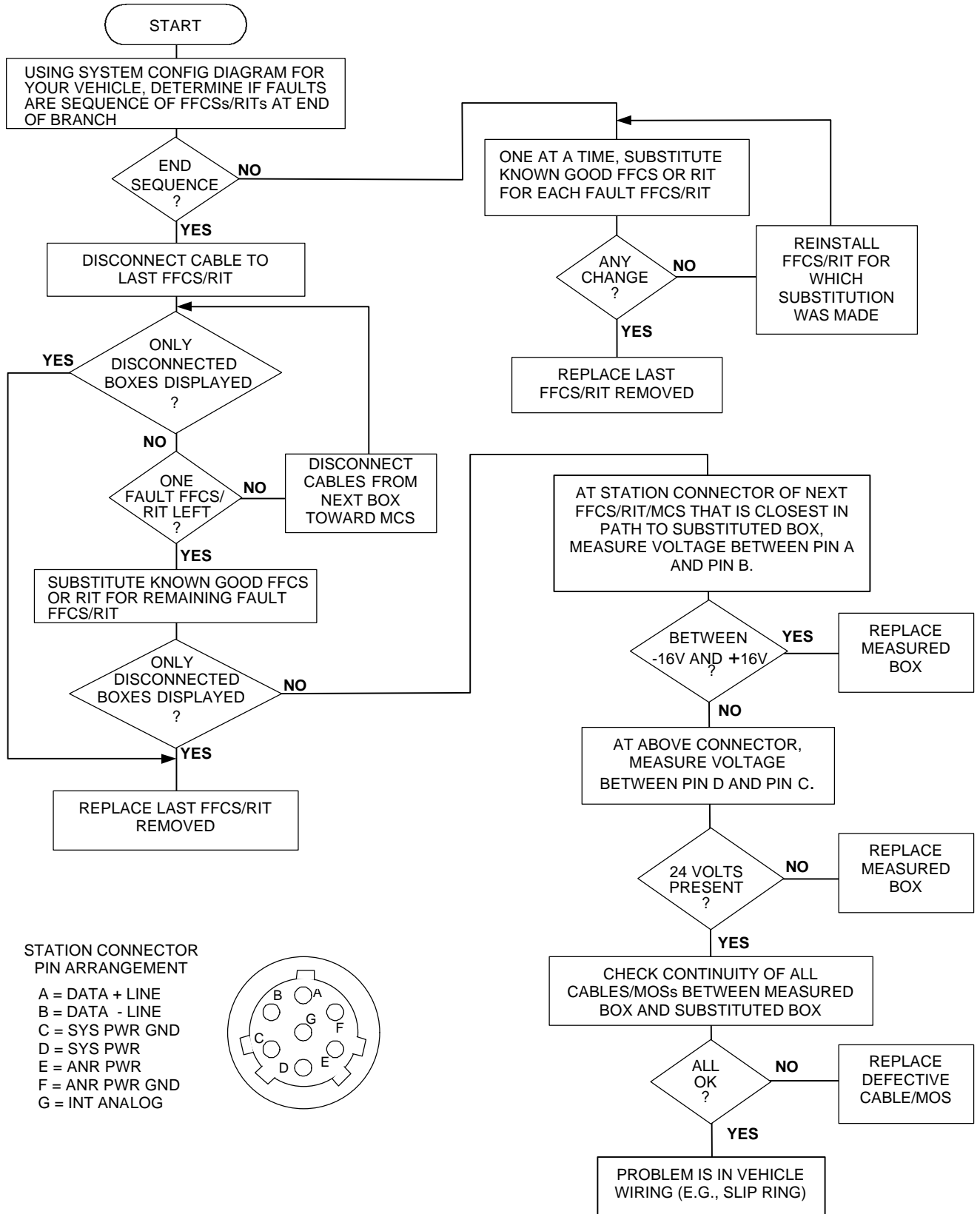

Figure 2-55. Multiple “Xu” Messages for Two-Branch Configuration Flowchart

SECTION VI TROUBLESHOOTING OF CABLE ASSEMBLIES

2.10. TROUBLESHOOTING OF CABLE ASSEMBLIES

When a Cable Assembly is identified in Section(s) IV or V of this Chapter as the failure item, refer to the Vehicle System Configuration Figures in Section II of this Chapter to identify the correct number of the cable. Identify the Part number and refer to Appendix H (Cable Assemblies, Pin Identification, Common Names and Signal Names) for the internal wiring and pin configuration of the cable.

Use a Multimeter set on "Continuity" or "Ohms" to perform a pin to pin check of the cable assembly using the internal wiring schematic and pin identification in Appendix H.

If the cable is found defective, refer to Chapter 3 for the Removal and Replacement Procedures.

CHAPTER 3 UNIT MAINTENANCE INSTRUCTIONS

SECTION I	General Information.....	3-1
SECTION II	LRU Removal and Replacement Procedures.....	3-1
SECTION III	Headset(s) Components Removal and Replacement Procedures	3-12
SECTION IV	Cable Removal and Replacement	3-30
SECTION V	LRU Knob(s) Removal and Replacement Procedures.....	3-31
SECTION VI	Preparation for Storage or Shipment	3-33

SECTION I GENERAL INFORMATION

3.1. SCOPE

This chapter covers removal and replacement procedures for three major groups of AN/VIC-3(V) or VIS (Vehicular Intercommunication Set) equipment: the Line Replaceable Units (LRU) (MCS, FFCS, RIT, MOS, LOUDSPEAKER), the Headset Components and the VIS Cabling (Highway, Power, Alarm, etc.). Additionally, Removal and Replacement Procedures for the Knobs on the LRU's are also covered.

SECTION II LRU REMOVAL AND REPLACEMENT PROCEDURES

CAUTION

REMOVE POWER FROM THE MCS BEFORE REMOVING OR REPLACING COMPONENTS/CABLES. FAILURE TO DO SO MAY RESULT IN DAMAGE TO COMPONENTS.

NOTE

Verify the crewstation(s) setting (1,2,3,4,5,6) for the FFCS and/or radio settings for the RIT(C/E, D/F) being removed so that the replacement FFCS/RIT can be correctly set. For instructions on setting the FFCS/RIT refer to the appropriate paragraph in Chapter 2.

The LRU's (MCS, FFCS, RIT, MOS) are mounted on studs or plates utilizing varying sequences of grounding straps and/or washers (lock and flat), and secured with either nuts or bolts. Paragraph 3.7 at the end of this section lists tables and figures showing the mounting sequences associated with the various LRU's. Refer to paragraph(s) 3.2 through 3.6 for removal and replacement procedures and instructions for the appropriate LRU. It should be noted that although some of the mounting sequences for LRUs for various vehicles look identical the actual parts might differ. Refer to the Repair Parts and Special Tools List (RPSTL) in Appendix C for proper identification of the correct part.

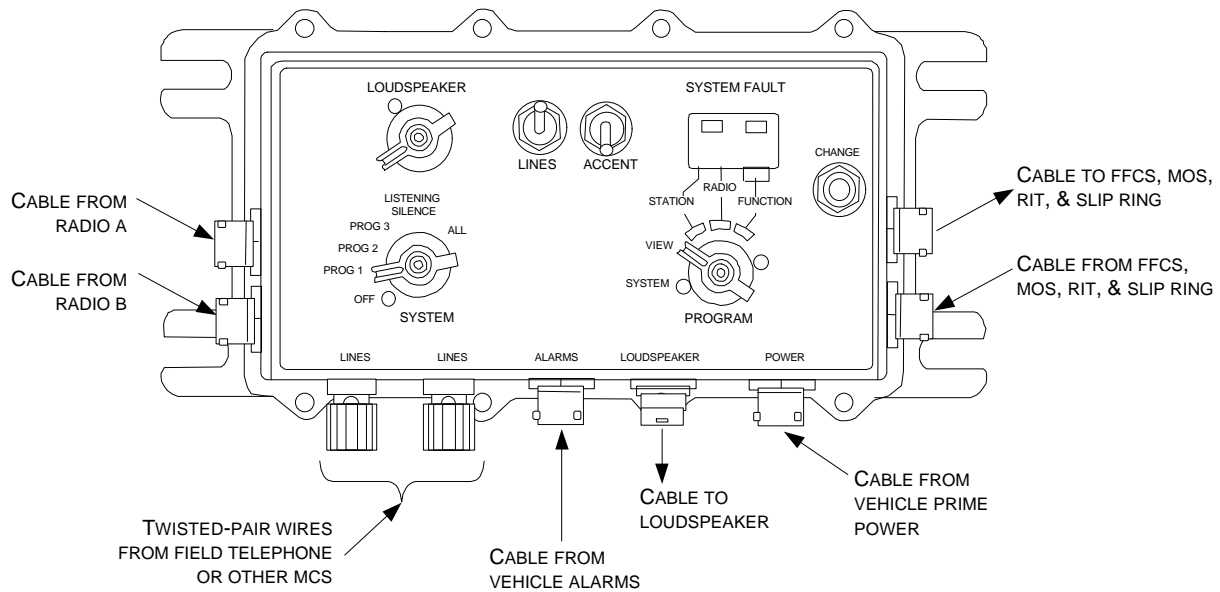

Figure 3-1. Master Control Station (MCS)

NOTE

Removal and replacement of the LRU's require the use of various size socket wrenches and open-end wrenches.

3.2. MCS REMOVAL AND REPLACEMENT (Fig. 3-1)

a. MCS Removal

1. Disconnect and tag the following cables from the MCS: ALARM, LOUDSPEAKER, POWER, RADIO (A/B), HIGHWAY (connected to the STATION connectors), and twisted-pair wires (connected to the binding posts). In some vehicles removal of the RADIO cables may require removing the MCS from the mounting bracket first due to clearance problems.
2. Refer to Table 3-1 and it's corresponding figure at the end of this section and remove mounting hardware securing the MCS.
3. Remove MCS.

b. MCS Replacement

1. Place MCS in position on studs or plate to be mounted.
2. Refer to Table 3-1 and it's corresponding figure at the end of this section for the proper mounting sequence and secure MCS.
3. Reconnect the following cables to the MCS: ALARM, LOUDSPEAKER, POWER, RADIO (A/B), HIGHWAY (connected to the STATION connectors), and twisted-pair wires (connected to the binding posts). In some vehicles connecting the RADIO cables to the MCS prior to mounting on the bracket may be required due to clearance problems.

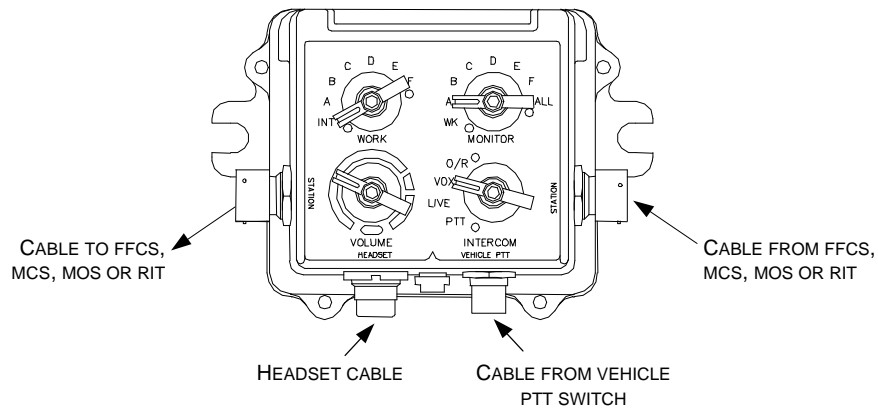

Figure 3-2. Full Function Crew Station (FFCS)

3.3. FFCS REMOVAL AND REPLACEMENT (Fig. 3-2)

- a. FFCS Removal
 1. Disconnect and tag the following cables from the FFCS: HEADSET, VEHICLE PTT SWITCH (if used) and HIGHWAY (connected to the STATION connectors).
 2. Refer to Table 3-2 and it's corresponding figure at the end of this section and remove mounting hardware securing the FFCS
 3. Remove FFCS and verify crewstation setting.

- b. FFCS Replacement
 1. Place correctly set FFCS in position on studs or plate to be mounted.
 2. Refer to Table 3-2 and it's corresponding figure at the end of this section for the proper mounting sequence and secure FFCS.
 3. Reconnect the following cables to the FFCS: HEADSET, VEHICLE PTT SWITCH (if used), and HIGHWAY (connected to the STATION connectors).

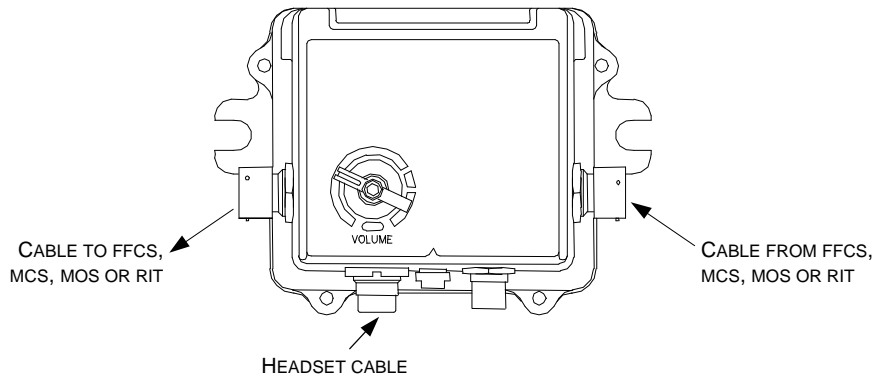

Figure 3-3. Monitor Only (Crew) Station (MOS)

3.4. MOS REMOVAL AND REPLACEMENT (Fig. 3-3)

a. MOS Removal

1. Disconnect and tag the following cables from the MOS: HEADSET and HIGHWAY (connected to the STATION connectors).
2. Refer to Table 3-3 and it's corresponding figure at the end of this section and remove mounting hardware securing the MOS.
3. Remove MOS.

b. MOS Replacement

1. Place MOS in position on studs or plate to be mounted.
2. Refer to Table 3-3 and it's corresponding figure at the end of this section for the proper mounting sequence and secure MOS.
3. Reconnect the following cables to the MOS: HEADSET and HIGHWAY (connected to the STATION connectors).

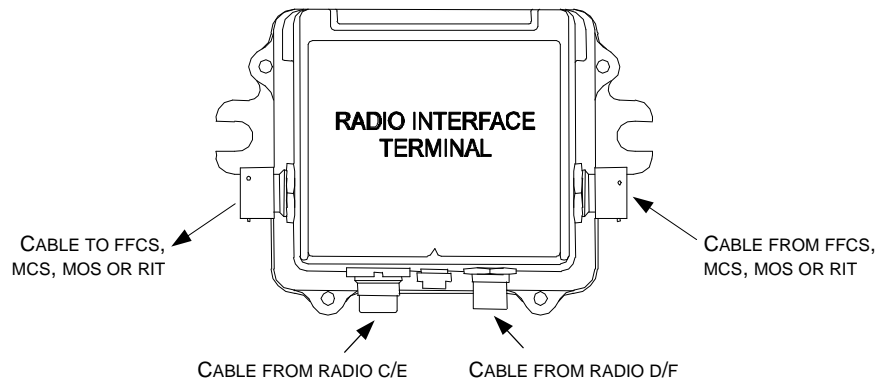

Figure 3-4. Radio Interface Terminal (RIT)

3.5. RIT REMOVAL AND REPLACEMENT (Fig. 3-4)

- a. RIT Removal
 1. Disconnect and tag the following cables from the RIT: RADIO(S) C/E and/or D/F and HIGHWAY (connected to the STATION connectors).
 2. Refer to Table 3-4 and it's corresponding figure at the end of this section and remove mounting hardware securing the RIT.
 3. Remove RIT and verify radio setting.
- b. RIT Replacement
 1. Place correctly set RIT in position on studs or plate to be mounted.
 2. Refer to Table 3-4 and it's corresponding figure at the end of this section for the proper mounting sequence and secure RIT.
 3. Reconnect the following cables to the RIT: RADIO(s) C/E and/or D/F and HIGHWAY (connected to the STATION connectors).

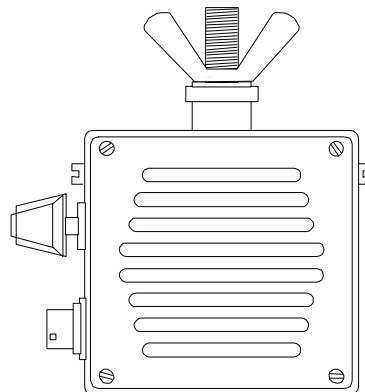

Figure 3-5. Loudspeaker (LS)

3.6. LOUDSPEAKER REMOVAL AND REPLACEMENT (Fig. 3-5)

Some vehicles have loudspeakers mounted on brackets while other vehicles stow the loudspeaker until needed. If a loudspeaker is mounted on a bracket loosening the wing nut allows the loudspeaker to be easily removed and replaced.

3.7. LINE REPLACEABLE UNITS (LRUs) MOUNTING SEQUENCES

The following steps describe the procedures for using the Tables and their corresponding Figures in identifying the correct mounting sequences of the various LRUs.

- a. Identify which LRU (MCS, FFCS, MOS, RIT) is being removed and replaced and refer to one of the following tables:
 - Table 3-1 MCS Mounting Hardware (Fig. 3-6)
 - Table 3-2 FFCS Mounting Hardware (Fig. 3-7)
 - Table 3-3 MOS Mounting Hardware (Fig. 3-8)
 - Table 3-4 RIT Mounting Hardware (Fig. 3-9)
- b. Find the “VEHICLE” column of the appropriate Table and identify the vehicle you are in.
- c. Find the “CREW STATION”/“ITEM” (FFCS, MOS, RIT) column of the appropriate Table and identify the LRU that is being removed and replaced for the selected vehicle.
- d. Find the “MOUNTING SEQUENCE” column of the appropriate Table and identify the mounting sequence that corresponds to the LRU being removed and replaced.
- e. Find the Figure that corresponds with the selected Table and match the mounting sequence selected from the Table with the mounting sequence in the Figure.

NOTE

The Mounting Hardware Sequence Figures (Figure 3-6, 3-7, 3-8, 3-9), show the ground strap for sequencing purposes only. For the correct location of the ground strap (left, right, top or bottom of the LRU) refer to the appropriate vehicle TB (Table 1-1).

Table 3-1. MCS Mounting Hardware (Figure 3-6)

VEHICLE	MOUNTING SEQUENCE
M1A1 ABRAMS, M1A2 ABRAMS	#6
M2A2 BRADLEY, M3A2 BRADLEY	#4
M577 COMMAND POST	#8
M109A6 PALADIN	#5
M1068 SICPS TRACKED	#8
S-787 SICPS RIGID WALL	#1
M2A2 ODS BRADLEY, M3A2 ODS BRADLEY	#4
HAB	#2
M992 FAASV	#9
M7 BFIST	#7
M88A2 RECOVERY VEHICLE	#10
ASV	#11
MLRS	#12
GRIZZLY (BREACHER)	#3
STRIKER	#12

Table 3-2. FFCS Mounting Hardware (Figure 3-7)

VEHICLE	CREW STATION	MOUNTING SEQUENCE
M1A1 ABRAMS, M1A2 ABRAMS	COMMANDER, GUNNER, LOADER	#9
	DRIVER	#2
M2A2 BRADLEY	ALL	#11
M3A2 BRADLEY	ALL	#11
M577 COMMAND POST	ALL	#13
M109A6 PALADIN	CHIEF OF SECTION, CANNONEER, GUNNER, AUXILIARY	#3
	DRIVER, EXTERNAL	#7
M1068 SICPS TRACKED	COMMANDER, OPERATOR #1	#13
	DRIVER, OPERATOR #2	#2
S-787 SICPS RIGID WALL	DRIVER, PASSENGER, OPERATOR #1	#4
	OPERATOR #2	#12
M2A2 ODS BRADLEY	COMMANDER, GUNNER, MACHINE GUNNER, DRIVER	#11
	DRIVER	#19
	DRAGON GUNNER, FIRE TEAM LEADER	#3
M3A2 ODS BRADLEY	ALL	#11
HAB	ALL	#5
M992 FAASV	ALL	#12
M7 BFIST	ALL	#14
M88A2 RECOVERY VEHICLE	ALL	#15
ASV	COMMANDER, DRIVER	#17
	GUNNER	#10
	PASSENGER	#6
MLRS	ALL	#18
GRIZZLY (BREACHER)	COMMANDER	#8
	DRIVER	#1
STRIKER	ALL	#16

Table 3-3. MOS Mounting Hardware (Figure 3-8)

VEHICLE	CREW STATION	MOUNTING SEQUENCE
M2A2 BRADLEY	TURRET (BASKET) SOLDIER	#2
	CURBSIDE, ROADSIDE SOLDIERS	#1
M2A2 ODS BRADLEY	RIFLEMAN #1	#1
	RIFLEMAN #2, GRENADIERS #1 and # 2	#2

Table 3-4. RIT Mounting Hardware (Figure 3-9)

VEHICLE	ITEM	MOUNTING SEQUENCE
M577 COMMAND POST	RIT	#2
M1068 SICPS TRACKED	RIT #1, RIT #2	#6
S-787 SICPS RIGID WALL	RIT #1	#1
	RIT #2	#5
M7 BFIST	RIT	#3
STRIKER	RIT	#4

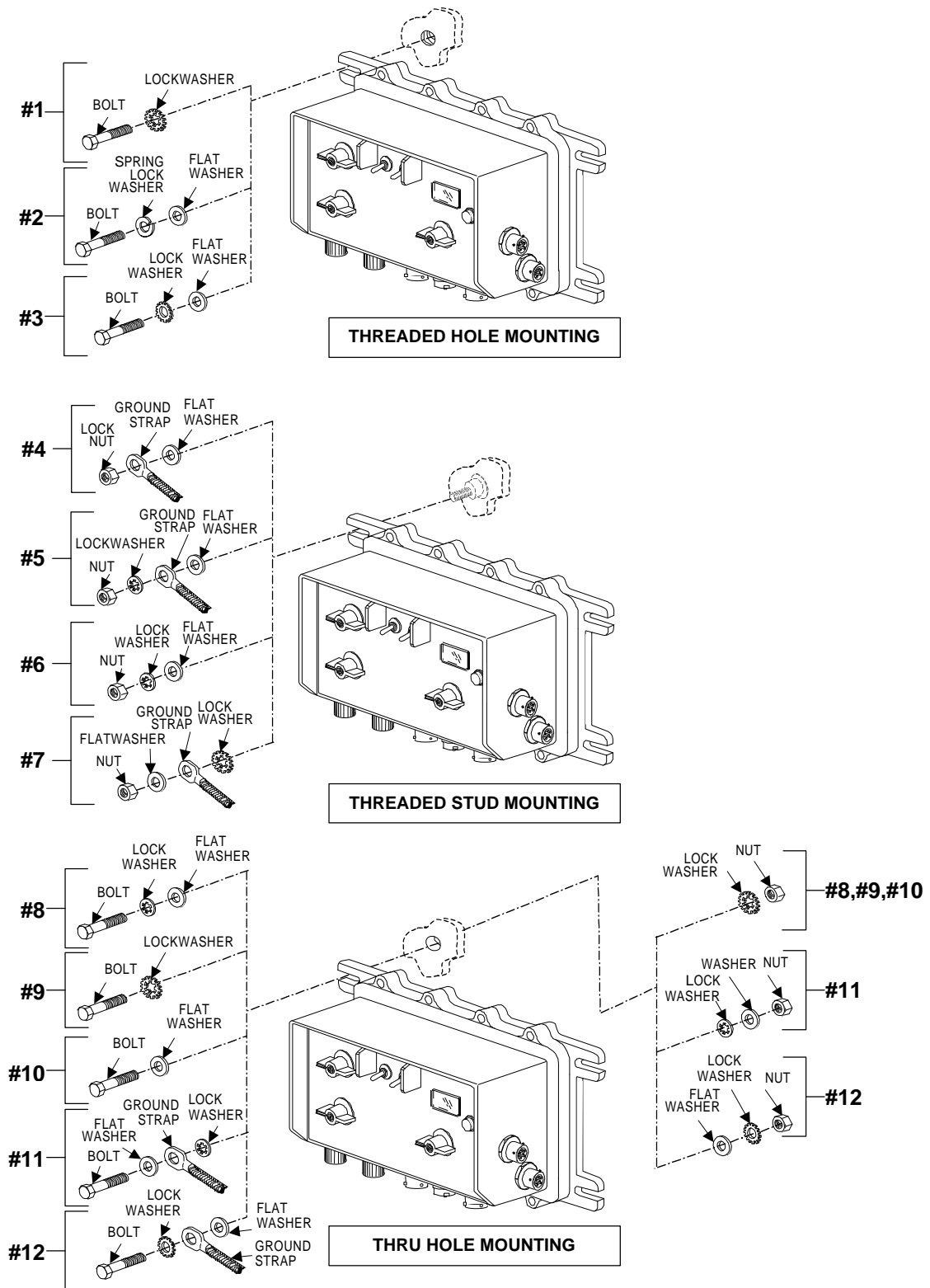

Figure 3-6. MCS Mounting Hardware Sequences

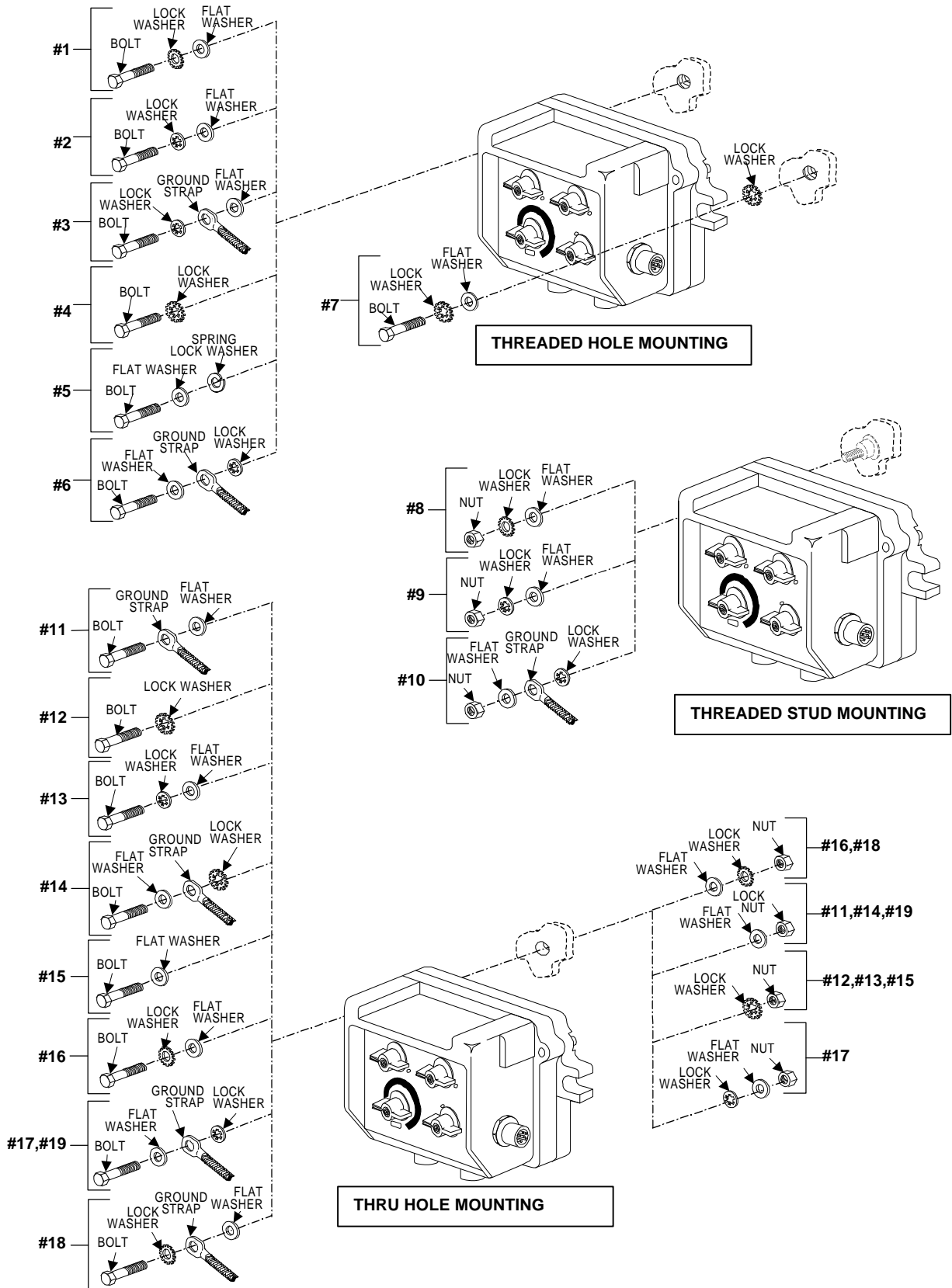

Figure 3-7. FFCS Mounting Hardware Sequences

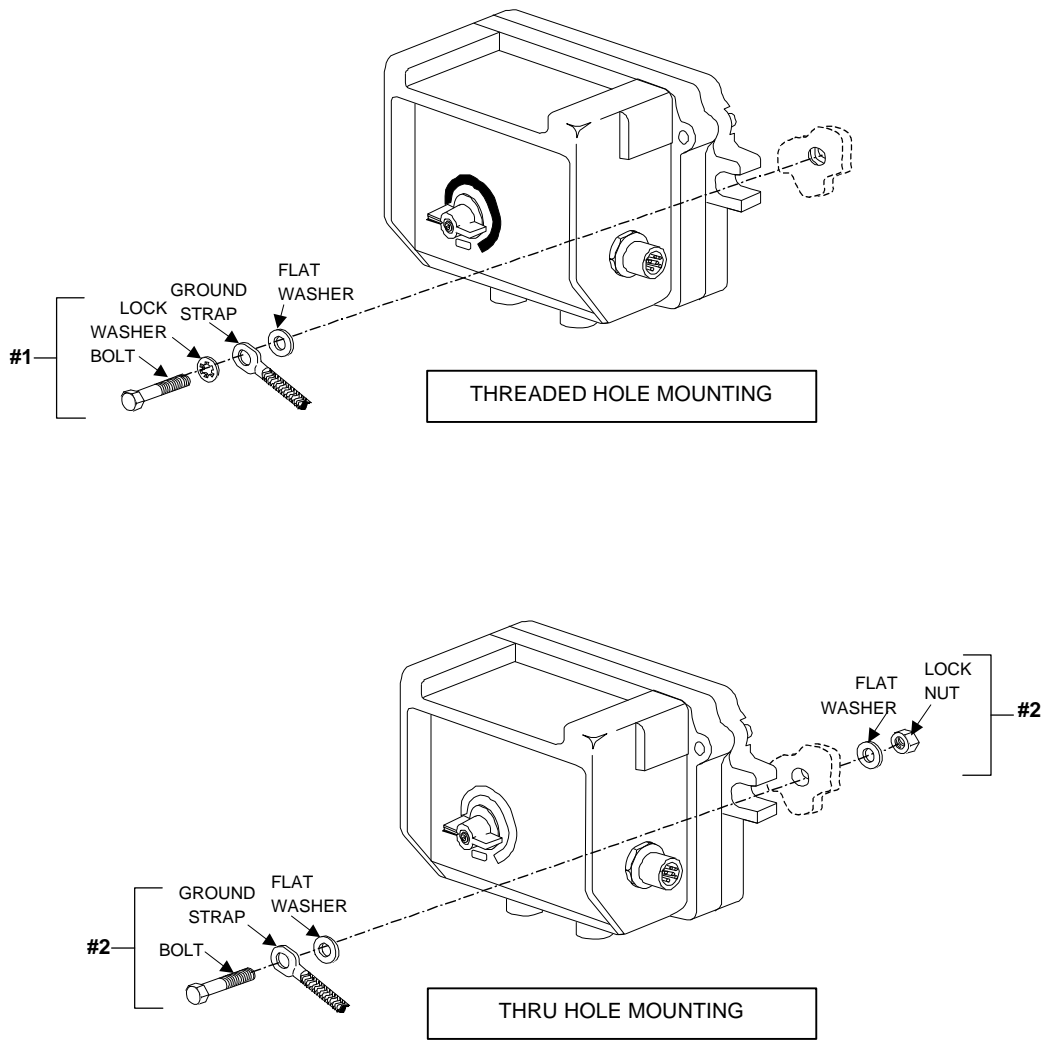

Figure 3-8. MOS Mounting Hardware Sequences

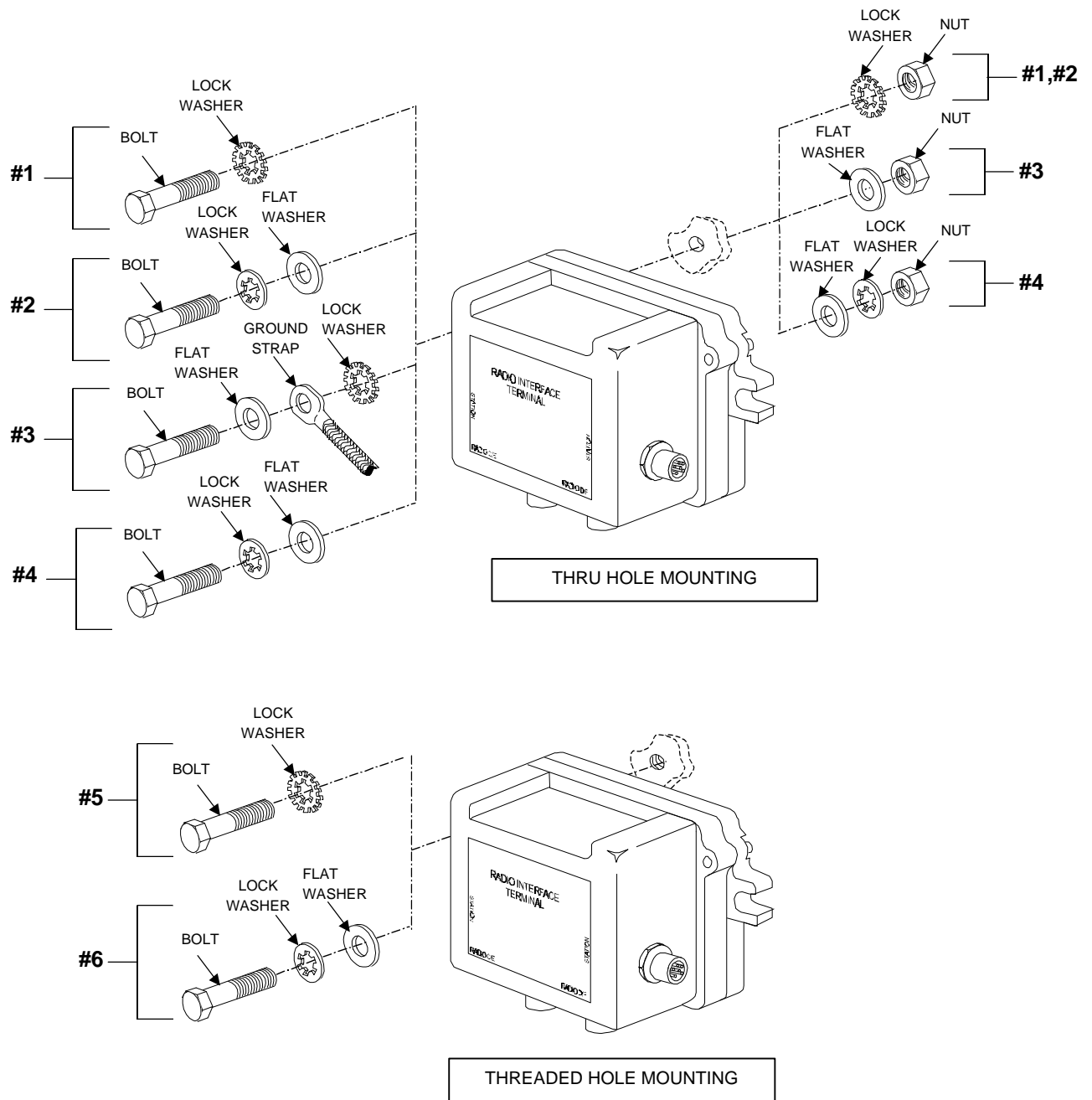

Figure 3-9. RIT Mounting Hardware Sequences

SECTION III HEADSET(S) COMPONENTS REMOVAL AND REPLACEMENT PROCEDURES

3.8. COMBAT VEHICLE CREWMAN (CVC) HEADSET COMPONENTS REMOVAL AND REPLACEMENT PROCEDURES

There are two designs of CVC headset (See Figure 3-10). The newer design, commonly referred to as "Product Improved" CVC (PICVC), has a one-piece microphone, boom, and cable assembly which is interchangeable with the earlier design CVC. Additionally, the PICVC has talk thru circuit (TTC) capability powered by either a rechargeable or AA alkaline battery located in a compartment situated on the left earcup. The new PICVC utilizes two liners (large, medium) instead of the three liners (large, medium, small) used the previous model CVC. All the liners are interchangeable with regards to the earcups and cable assembly fitting into them. The pads installed in the PICVC liner have been improved and can be removed and replaced. These pads, which come in large and medium kit sizes, are interchangeable with the pads in the earlier design CVC liner. The set of large pads is installed in both large liners. The set of medium pads is installed in both medium liners as well as the CVC small liner.

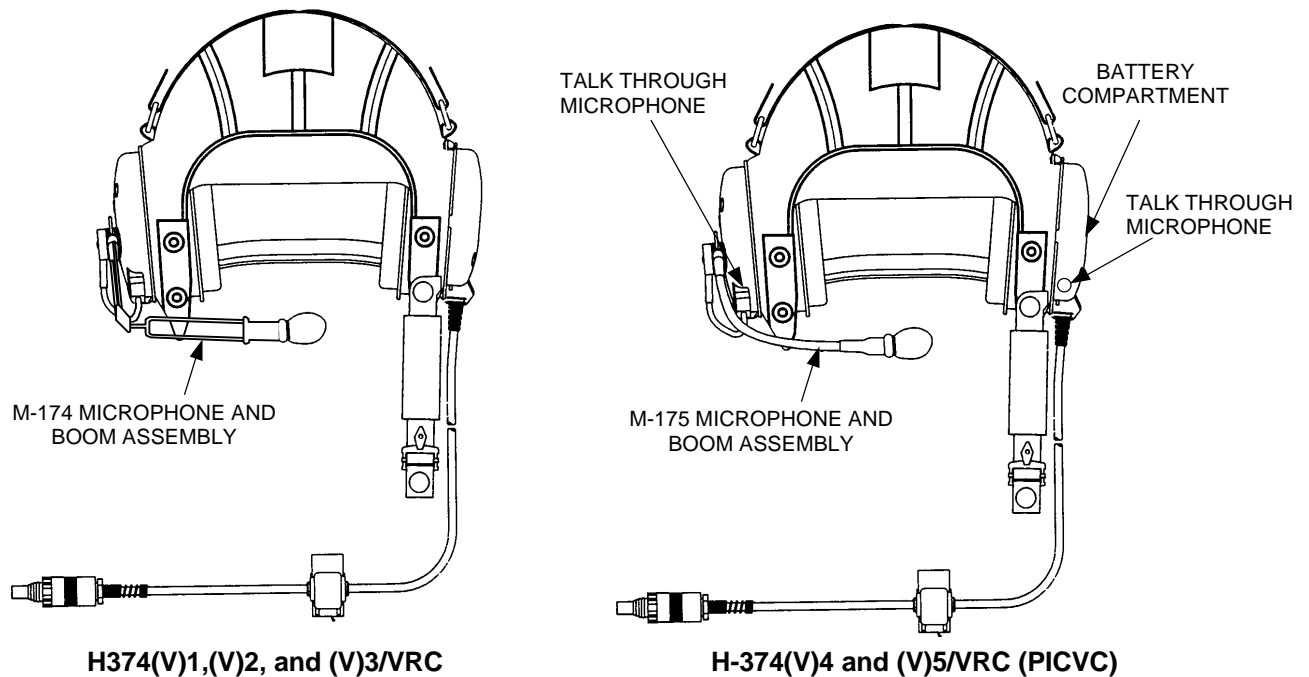

Figure 3-10. CVC Headset

NOTE

Unless otherwise specified, the following removal and replacement procedures are identical for both designs of the CVC Headset.

3.8.1. Liner and Earcup Assembly Removal and Replacement (Fig. 3-11)

Figure 3-11. Liner and Earcups Assembly.

a. Removal

1. Firmly grasp an earcup (2) in one hand with thumb on the outer shell and fingers on earcushion (3).
2. With other hand grasp liner (1) above the earcup (2) with thumb on the outside and fingers on the inside of liner (1).
3. Firmly peel liner (1) up and outward from earcup (2) while at the same time use the thumb placed on outer shell to push earcup (2), and any attachments through liner (1) opening until free.
4. Repeat steps 1 through 3 above for other earcup.
5. Undo Velcro strap securing earcup cable to liner (1) and separate earcups and cable assembly from liner (1).

NOTE

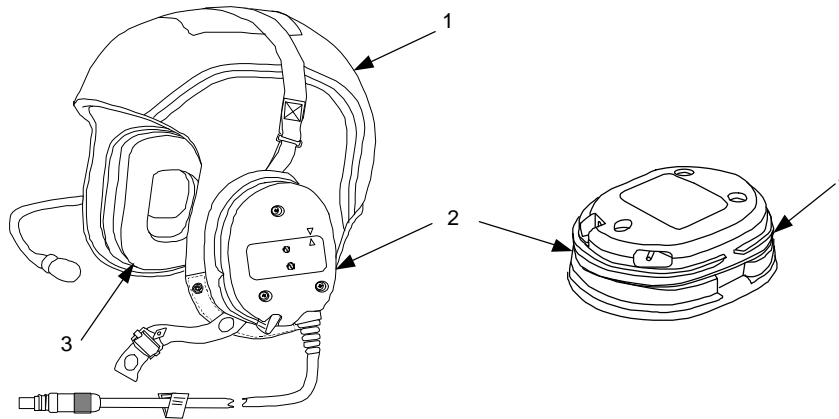
The side of the earcup(s) containing the cord assembly connection(s) should be pointed towards the rear of the liner when placing the earcups into the liner opening.

b. Replacement

1. From the inside of the liner place earcup (2), with any attachments, part way through opening in the liner (1).
2. Start at the top of liner opening and insert liner ribbing into channel (4) on earcup (2) and hold in place.
3. While holding in place, start working liner ribbing into earcup channel (4) all around until fully seated.
4. Repeat steps 1-3 for other earcup.
5. Place earcup cable in Velcro at bottom rear of liner (1) and secure.

3.8.2. Earcushion, O-Ring and Front Foam Assembly Removal and Replacement (Fig. 3-12)

CAUTION

DO NOT ATTEMPT TO REMOVE THE EARCUSHION BY PULLING ON THE SOFT EARSEAL MATERIAL.

CAUTION

THE CVC HEADSET CONTAINS A CIRCUIT CARD ASSEMBLY SENSITIVE TO DAMAGE BY ELECTROSTATIC DISCHARGE (ESD).

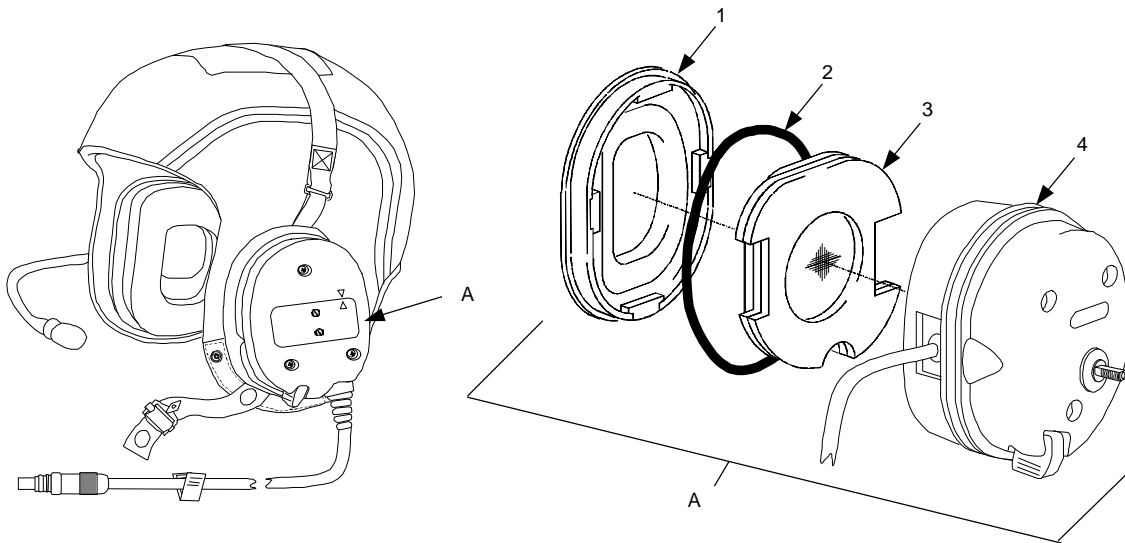

Figure 3-12. Earcushion and Front Foam Assembly

a. Removal

1. Grasp earcushion assembly with installed o-ring (1 and 2) lengthwise with thumb and fingers hooked under earcushion assembly lip.
2. Peel earcushion assembly (1) from earcup (4) by tilting one end until free of earcup.
3. Remove front foam assembly (3) from earcup.

b. Replacement

1. Insert front foam assembly (3) into earcup (4).
2. Install o-ring (2) into groove on earcushion assembly (1).
3. Align earcushion assembly (1) on earcup (4).
4. Press earcushion assembly (1) firmly until secured in place.

3.8.3. Windscreen and O-Ring Removal and Replacement (M-175/VRC, Fig. 3-13)

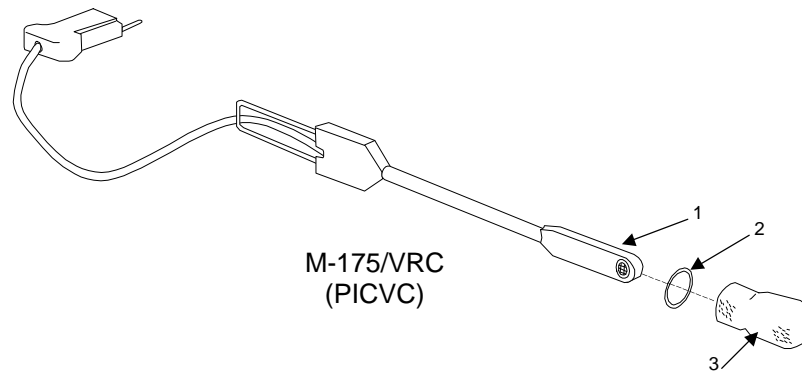

Figure 3-13. Microphone, Boom, and Cable Assembly

a. Removal

1. Grasp O-ring (2) between thumb and forefinger and slide O-ring (2) and windscreen (3) off microphone (1).
2. Separate O-ring (2) from windscreen (3).

CAUTION

WHEN PLACING WINDSCREEN/O-RING ON MICROPHONE BE CAREFUL NOT TO TEAR WINDSCREEN.

b. Replacement

1. Compress closed end of windscreen (3) and place inside O-ring (2) until O-ring (2) is midway on windscreen (3).
2. Slide O-ring (2)/windscreen (3) onto microphone (1) and adjust O-ring (2) until windscreen (3) is secured.

3.8.4. Boom Assembly/Mounting Hardware Removal and Replacement (Fig. 3-14)

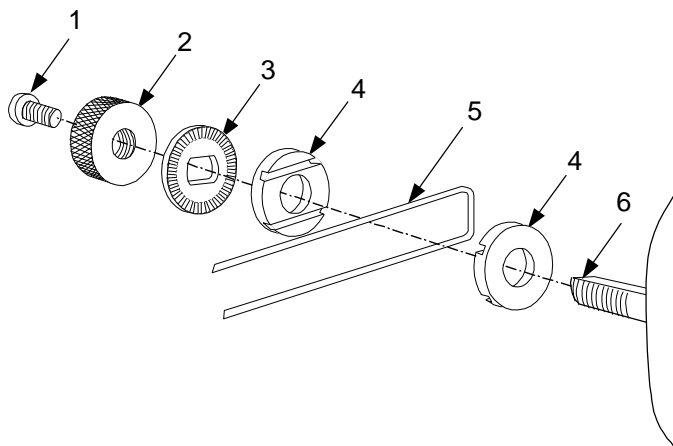

Figure 3-14. Boom Assembly and Mounting Hardware

a. Removal

1. Using a cross-tipped screwdriver remove screw (1) securing mounting hardware to headset.
2. Unscrew knurled thumbnut (2).
3. Remove boom clamp (3), boom guides (4), and boom assembly (5) by sliding off mounting post (6)

b. Replacement

1. Align boom assembly (5) arms into slots between the two boom guides (4) and hold in place.
2. Place, boom guides (4) with boom assembly (5) on the mounting post (6) and hold in place.
3. Place boom clamp (3) on mounting post (6) so that the serrated edge is flush against the boom guide (4) and hold in place.
4. Place knurled thumb nut (2) on mounting post (6) and turn clockwise and tighten until secure.
5. Using a cross tipped screwdriver place screw (1) in end of mounting post (6) and tighten until secured.

3.8.5 Helmet Liner Insert Removal and Replacement Procedures (Fig. 3-15)

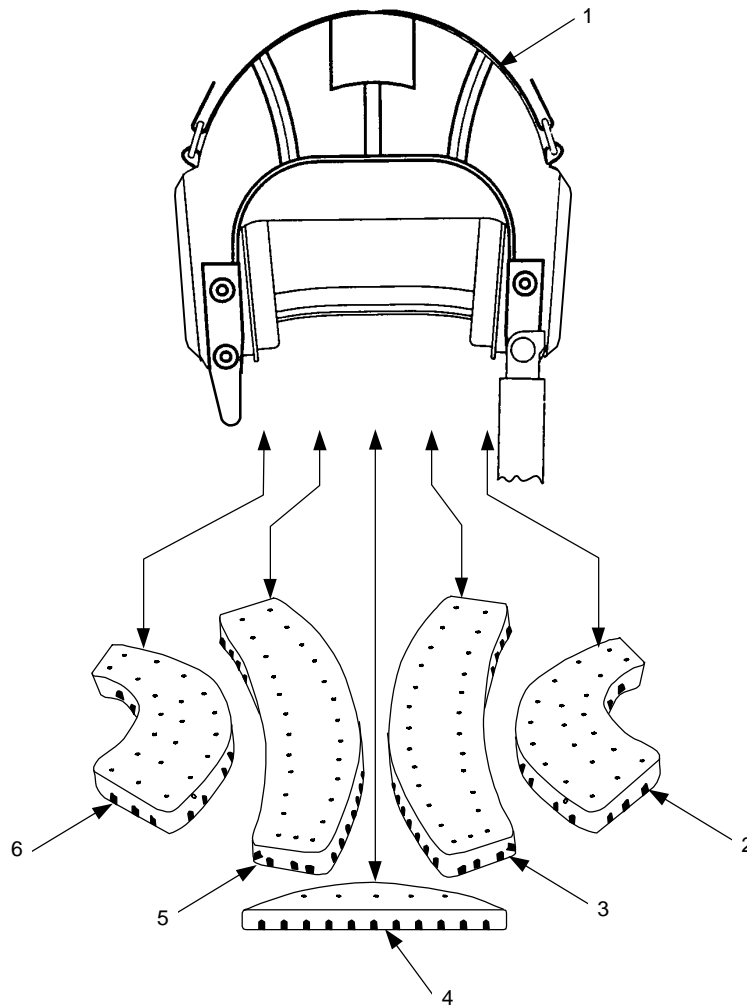

Figure 3-15. Helmet Liner Inserts

a. Removal

1. Locate insert(s) (2 through 6) to be removed. Grasp liner (1) in one hand and place fingers beneath the insert at the opening provided in the liner pouch. Carefully free one end of the insert (2 through 6) from the liner pouch.
2. Reverse liner (1) in hand and grasp the insert (2 through 6). Carefully free other end from the liner pouch.

b. Replacement

1. Grasp liner (1) in one hand. Carefully feed one end of insert (2 through 6) into liner pouch opening until end is fully installed.
2. Reverse liner (1) in hand and feed the other end of insert (2 through 6) into liner pouch opening until insert is fully installed.
3. Smooth out any wrinkles or bumps in the liner until insert is fully secured.

3.8.6 Switch Cover Removal and Replacement Procedures (Fig. 3-16)

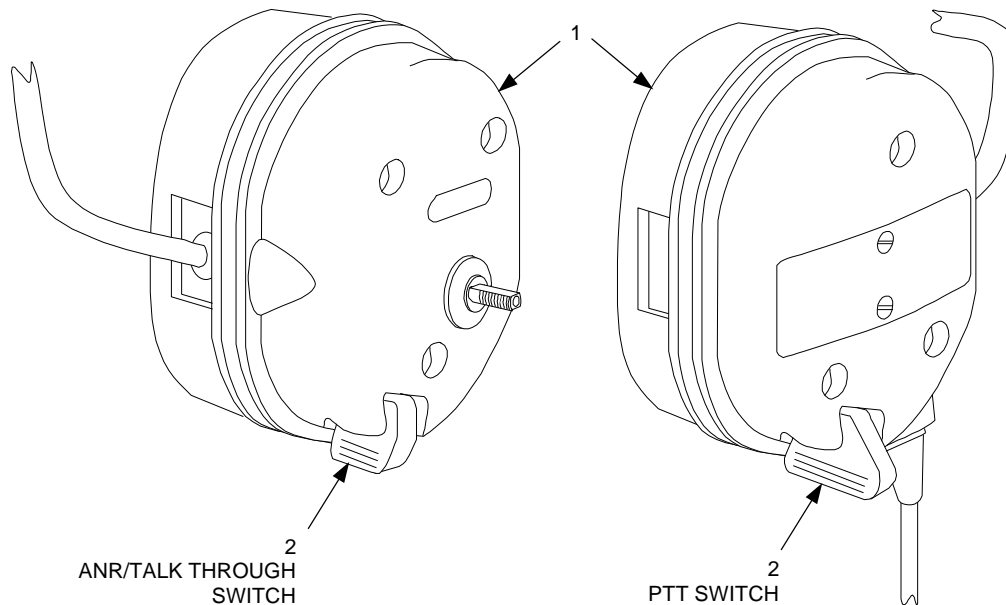

Figure 3- 16. Switch Cover(s)

a. Removal

1. Hold earcup and cable assembly (1) in one hand and grasp switch cover (2) firmly with other hand.
2. Pull switch cover (2) firmly, until cover is free of toggle switch assembly.

b. Replacement

1. Position switch cover (2) on toggle switch assembly.
2. Apply pressure on switch cover (2) until it snaps into place on toggle switch assembly.

3.8.7 Battery and Battery Cover Removal and Replacement Procedure (PICVC Headset only) (Fig. 3-17)

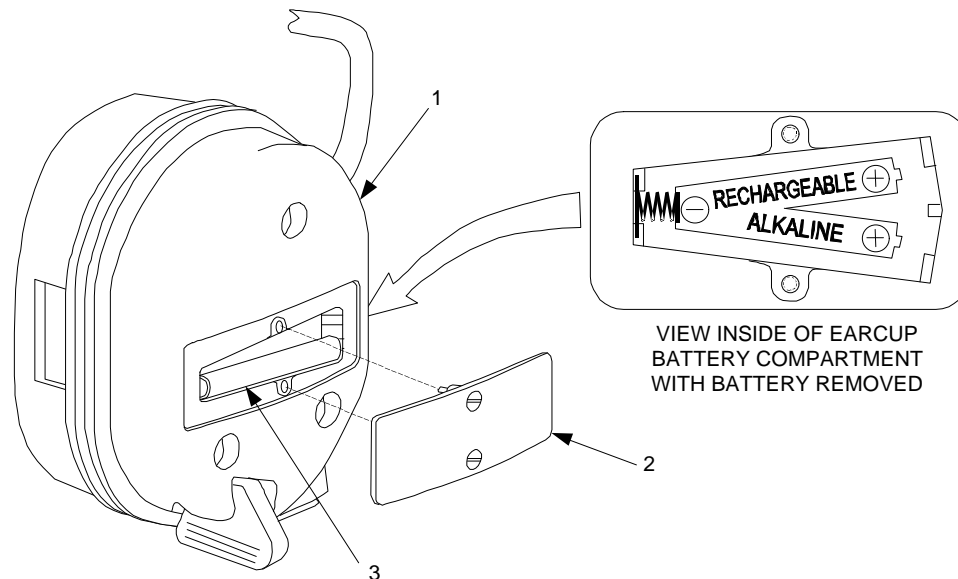

Figure 3-17. Battery and Battery Cover

a. Removal

1. Using a flat tipped screwdriver, loosen the captive screws securing the battery cover (2) to the earcup (1) and remove the battery cover.
2. Grasp battery (3) and remove from battery compartment.

b. Replacement

WARNING

WHEN INSTALLING REPLACEMENT BATTERY IN THE CVC HELMET BATTERY COMPARTMENT, DO NOT PLACE ALKALINE AA BATTERY IN THE RECHARGEABLE SLOT. PLACE THE ALKALINE AA BATTERY IN THE ALKALINE SLOT ONLY. ALKALINE BATTERIES MAY EXPLODE OR LEAK IF RECHARGED OR CONNECTED IMPROPERLY.

1. Examine battery to determine whether it is a rechargeable or alkaline type and locate proper slot identified in the earcup battery compartment.
2. Insert the rechargeable battery in the "rechargeable" slot, or the alkaline battery in the "alkaline" slot, as shown in the earcup battery compartment.
3. Position the battery cover (2) on the earcup (1) battery compartment. Using a flat tipped screwdriver, tighten captive screws until battery cover is secure.

3.9. ACAPS (PNR TYPE B) AND CAPS (PNR/ANR TYPE(S) I AND II) HEADSET(S) COMPONENTS REMOVAL AND REPLACEMENT PROCEDURES

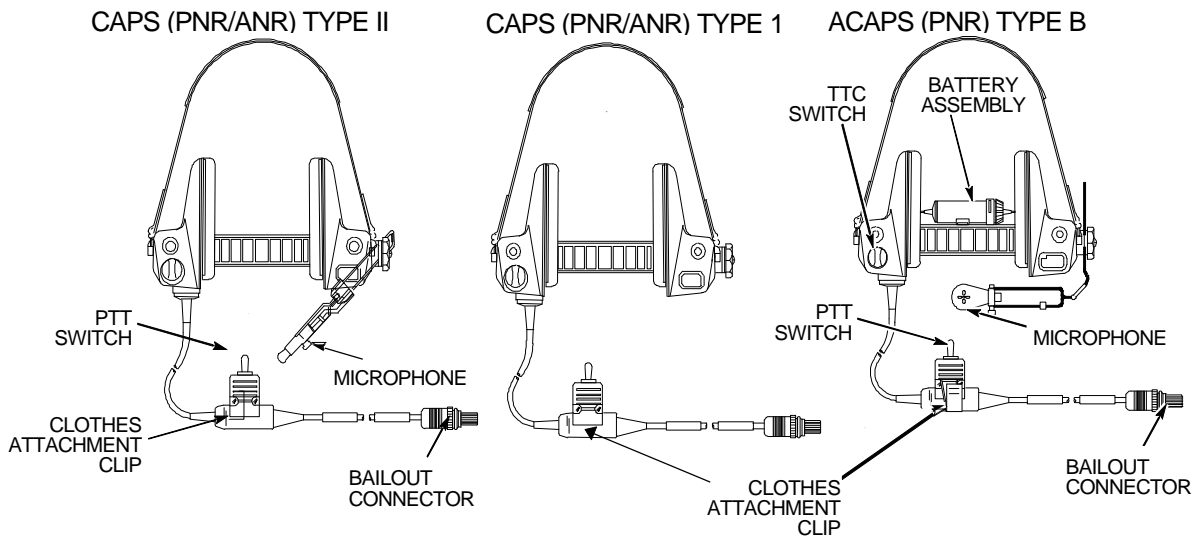

Figure 3-18. CAPS and ACAPS Headsets Major Components

NOTE

The following Removal and Replacement Procedures pertain to the CAP Type I and Type II and ACAPS Type B headsets, unless a specific headset is identified.

3.9.1. Earcushion, Damp Cover, and Foam Damper Removal and Replacement (Fig. 3-19)

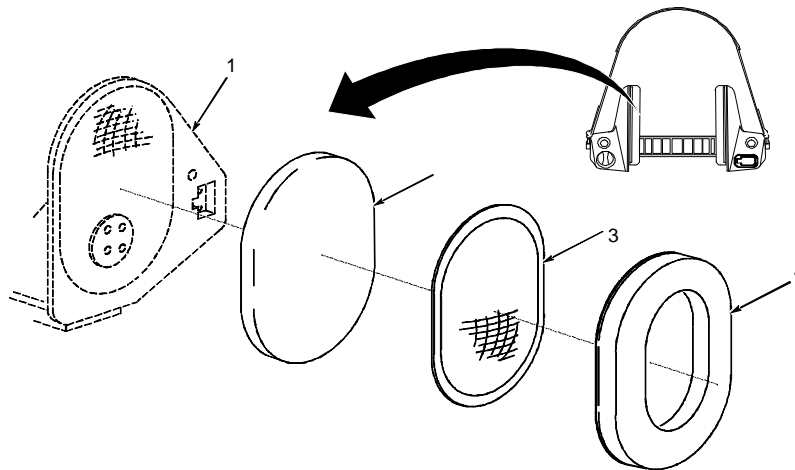

Figure 3-19. Earcushion, Damp Cover and Foam Damper

a. Removal

NOTE

For ease in removing the earcushion, insert fingers between the foam damper and earcushion on the side of the earcup where the spring assembly is attached.

1. Remove earcushion (4) from earcup assembly (1) by inserting fingers inside earcup between damp cover (3) and earcushion (4) and firmly pulling out.
2. Remove damp cover (3) and foam damper (2) after earcushion (4) is removed.

b. Replacement

1. Align foam damper (2) and damp cover (3) and place on earcup assembly (1).
2. While holding foam damper (2) and damp cover (3) in place, align and set earcushion (4) on earcup assembly (1) and snap in place.

3.9.2. Overhelmet Strap Assembly Removal and Replacement (Fig. 3-20)

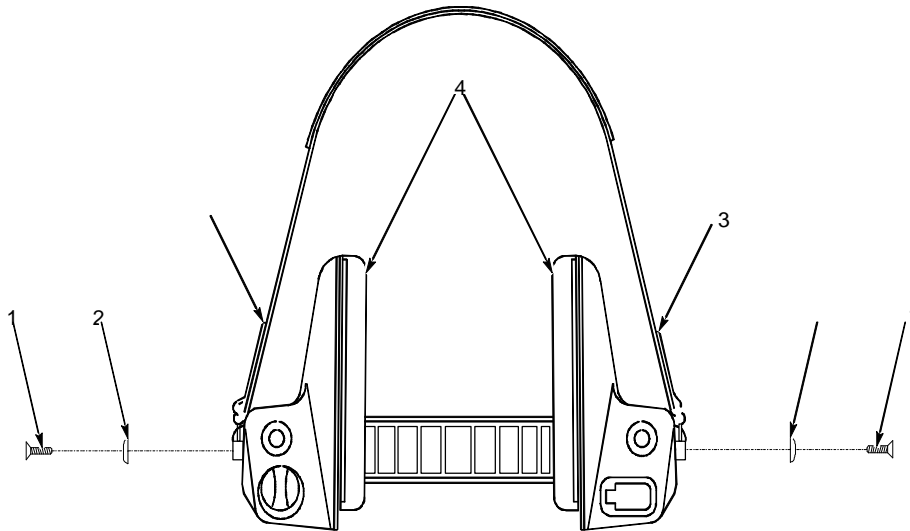

Figure 3-20. Overhelmet Strap Assembly

NOTE

The overhelmet strap assembly consists of two Velcro strap sections, hooks and loops. When replacing a single strap at a time make sure the replacing strap is the same as the one being removed.

a. Removal

Using a cross-tipped screwdriver remove screw (1) and anchor washer (2) securing overhelmet strap (3) to earcup assembly (4).

CAUTION

DO NOT USE THREAD SEALANT OR LOCKING COMPOUND. DOING SO COULD CAUSE DAMAGE TO THE EARCUPS ASSEMBLY.

b. Replacement

Place screw (1) and anchor washer (2) through opening in end of overhelmet strap (3) and use a cross-tip screwdriver to secure to earcup assembly (4).

3.9.3. Neckband (Spring Assembly) Cover Removal and Replacement (Fig. 3-21)

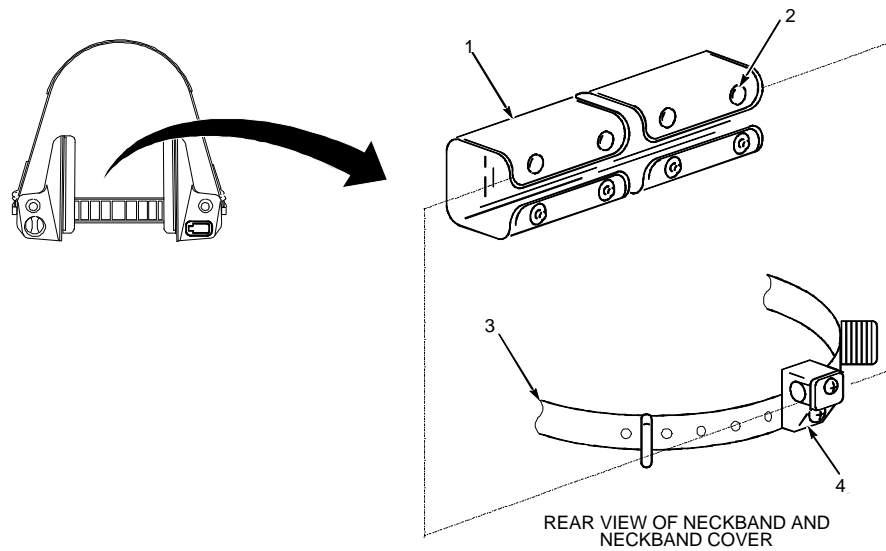

Figure 3-21. Neckband (Spring Assembly) Cover

a. Removal

Unsnap four snaps (2) securing neckband cover (1) to neckband (3) and remove.

b. Replacement

Wrap neckband cover (1) around neckband (3) with snaps (2) facing back and split in neckband cover around wire clamp (4) and snap in place.

3.9.4. Neckband (Spring Assembly) Removal and Replacement (Fig. 3-22)

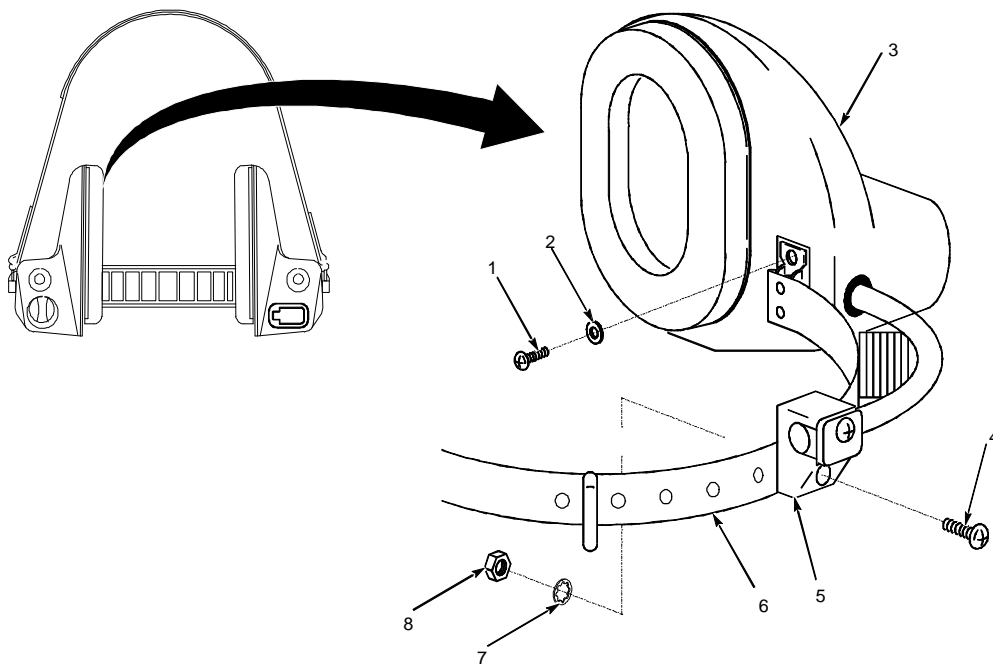

Figure 3-22. Neckband (Spring Assembly)

a. Removal

1. Remove neckband cover (Para. 3.9.3a).
2. Using a cross-tipped screwdriver, remove screw (4), nut (8), and lock washer (7) securing cable clamp (5) to neckband (6).
3. Using a cross-tipped screwdriver, remove screws (1) and crinkle washers (2) securing neckband (6) to right and left earcups (3).

b. Replacement

1. Using a cross-tipped screwdriver, install screws (1) and crinkle washers (2) on neckband (6) and secure to right and left earcups (3).
2. Using a cross-tipped screwdriver, install screw (4), nut (8), and lock washer (7) securing cable clamp (5) to neckband (6).
3. Install neckband cover (Para. 3.9.3b).

3.9.5. Windscreen and O-Ring Removal and Replacement (CAPS Type II) (Fig. 3-23)

a. Removal

1. Grasp O-ring (6) between thumb and forefinger and slide O-ring (6) and windscreen (7) off microphone (5).
2. Separate O-ring (6) from windscreen (7).

CAUTION

WHEN PLACING WINDSCREEN/O-RING ON MICROPHONE BE CAREFUL NOT TO TEAR WINDSCREEN.

b. Replacement

1. Compress closed end of windscreen (7) and place inside O-ring (6) until O-ring (6) is midway on windscreen (7).
2. Slide O-ring (6)/windscreen (7) onto microphone (5) and adjust O-ring (6) until windscreen (7) is secured.

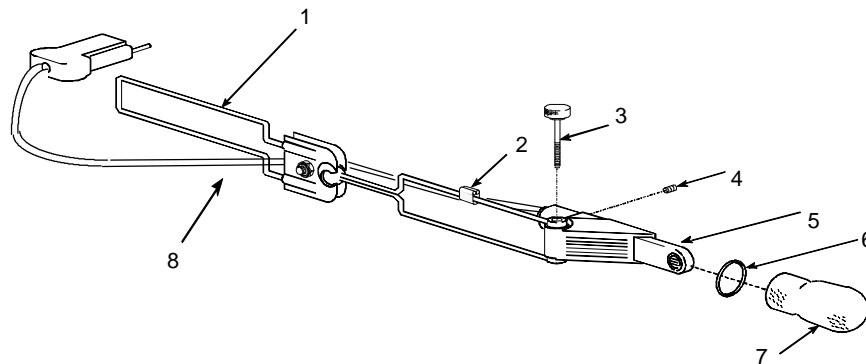

Figure 3-23. M-172 Microphone and Boom Assembly

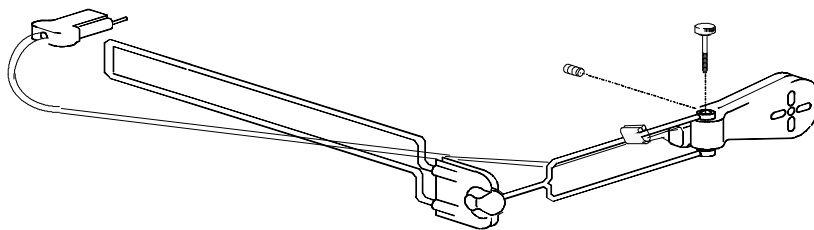

Figure 3-24. M-173 Microphone and Boom Assembly

3.9.6 Microphone Removal and Replacement (ACAPS Type B and CAPS Type II) (Fig. 3-23 and FIG. 3-24)

NOTE

The removal and replacement procedures for both the microphone and cable assemblies shown above, (M-172, Fig. 3-23 and M-173 Fig. 3-24) are identical, even though the microphones are different, the attachment points and hardware are the same. The Figure and Item numbers used are referenced from Fig. 3-23.

NOTE

If defective/lost the two setscrews securing the microphone cable to the microphone can be removed/replaced.

- a. Removal
 1. Using a flat head screwdriver loosen but do not remove the two setscrews (4) securing microphone cable (8) to microphone (5).
 2. Disconnect microphone cable (8) from microphone (5).
 3. Using a flat head screwdriver remove screw (3) securing microphone (5) to boom assembly (1). If a thumbscrew is used to secure microphone (5) to boom assembly (1) simply unscrew until free from boom assembly (1).
 4. Spread arms of boom assembly (1) and remove microphone (5).
- b. Replacement
 1. Spread arms of boom assembly (1) and place microphone (5) between boom guides.
 2. Insert screw (3) through unthreaded end of boom assembly (1) guide bearings and using a flat head screwdriver tighten until secured. If a thumbscrew is utilized hand tighten until secured.
 3. Using a flat head screwdriver loosen but do not remove two setscrews (4) on microphone (5).
 4. Connect microphone cable (8) to microphone (5) and holding firmly in place tighten the two setscrews (4) with flat head screwdriver until microphone cable (8) is secured to microphone (5).

3.9.7 Microphone Cable Assembly Removal and Replacement (ACAPS TYPE B and CAPS TYPE II) (FIG. 3-23 and Fig. 3-24)

NOTE

Tighten setscrews after removal of microphone cable to prevent loss until microphone cable is replaced.

- a. Removal
 1. Remove microphone clip (2) securing microphone cable assembly (8) to boom assembly (1) and set aside.
 2. Using a flat head screwdriver loosen but do not remove the two setscrews (4) securing the microphone cable (8) to the microphone (5).
 3. Disconnect microphone cable (8) from microphone (5) and headset.
- b. Replacement
 1. Plug microphone cable assembly (8) jack into headset receptacle.
 2. Connect microphone cable (8) to microphone (5) and holding firmly in place, tighten the two setscrews (4) with flat head screwdriver until microphone cable is secured.
 3. While holding microphone cable assembly (8) against boom assembly (1) arm secure with microphone clip (2).

3.9.8. Boom Assembly/Mounting Hardware Removal and Replacement (ACAPS Type B and CAPS Type II) (Fig. 3-25)

NOTE

The boom assembly and mounting hardware removal and replacement procedures are combined as the removal and replacement of one item effects the other.

NOTE

If required the Microphone, Boom, and Cable Assembly can be removed in its entirety. Unplug the microphone cable jack from the headset port and follow the procedural steps for removing and replacing the mounting hardware only.

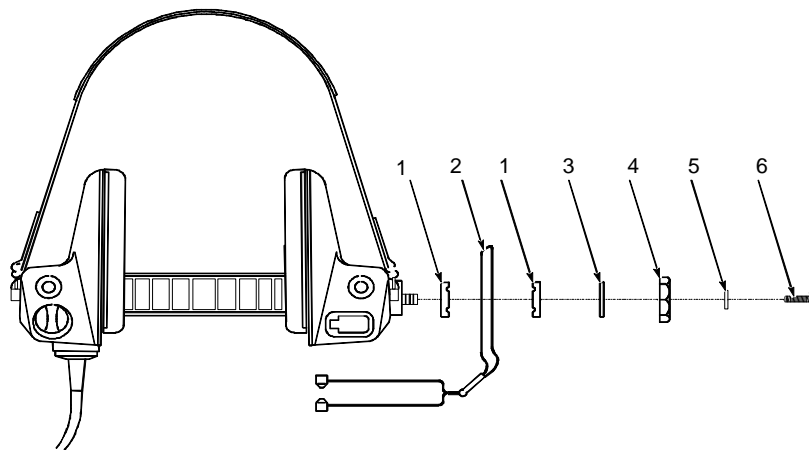

Figure 3-25. Microphone Boom Assembly Removal and Replacement (ACAPS Type B and CAPS Type II)

a. Removal

1. Using a cross-tipped screwdriver remove screw (6) and washer (5) securing mounting hardware to headset.
2. Unscrew knob (4).
3. Remove boom clamp (3), boom guides (1), and boom assembly (2) by sliding off mounting post.

b. Replacement

1. Align boom assembly arms (2) into slots between the two boom guides (1) and hold in place.
2. Place boom guides (1) with boom assembly (2) on the mounting post and hold in place.
3. Place boom clamp (3) on mounting post so that the serrated edge is flush against the boom guide (1) and hold in place.
4. Place knob (4) on mounting post and turn clockwise and tighten until secure.
5. Using a cross tipped screwdriver place washer (5) and screw (1) in end of mounting post and tighten until secured.

3.9.9. Socket Blanking Plug Removal and Replacement (CAPS Type 1) (Fig. 3-26)

If the socket blanking plug is deteriorated or missing replace as shown in Fig. 3-26.

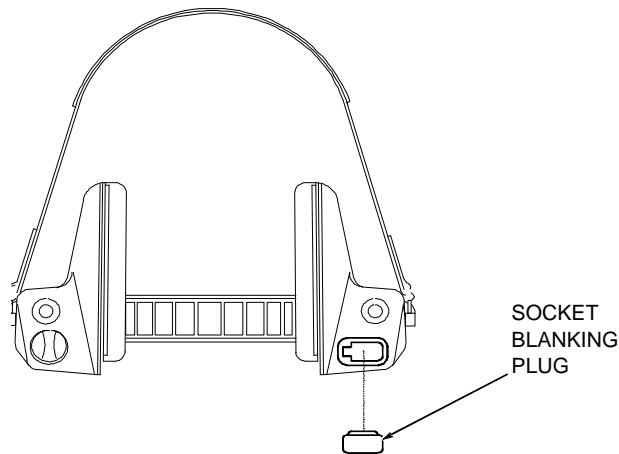

Figure 3-26. Socket Blanking Plug (CAPS Type 1)

3.10. COMMAND AND CONTROL HEADSET COMPONENTS REMOVAL AND REPLACEMENT PROCEDURES (FIG. 3-27)

CAUTION

THE COMMAND AND CONTROL HEADSET CONTAINS AN EARPHONE WITH WIRE CONNECTIONS (8 OF FIGURE 3-27) THAT MUST BE HANDLED VERY CAREFULLY WHEN THE FOAM EARPHONE HOLDER IS REMOVED FROM THE EARCUP.

NOTE

Removal and replacement procedures for the microphone, boom assembly and mounting hardware are identical to the procedures described in previous paragraphs for other headsets. The microphone cable assembly cannot be removed and replaced, as it is part of the headset.

3.10.1. Microphone Removal and Replacement Procedures (Fig. 3-27)

For microphone removal and replacement refer to paragraph 3.9.6.

3.10.2. Boom Assembly/Mounting Hardware Removal and Replacement Procedures (Fig. 3-27)

For boom assembly/mounting hardware removal and replacement refer to paragraph 3.8.6.

NOTE

The microphone cable assembly cannot be removed, as it is hardwired in.

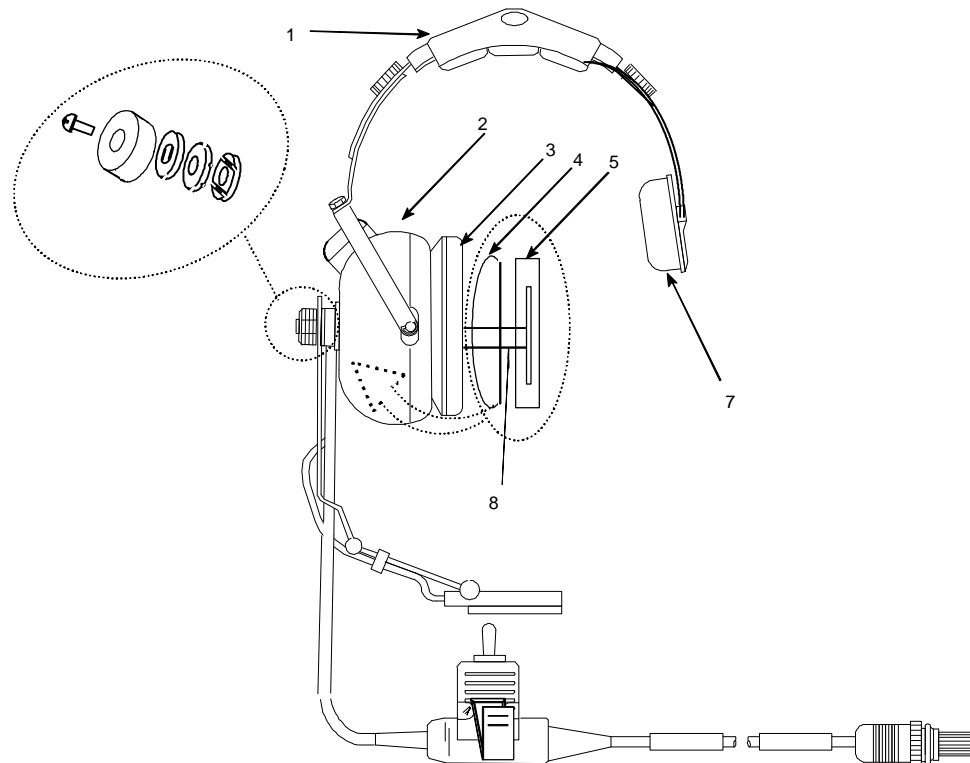

Figure 3-27. Command and Control Headset

3.10.3. Earcushion, Earphone Holder, and Back Pad Removal and Replacement (Fig. 3-27)

CAUTION

BE CAREFUL NOT TO DAMAGE EARPHONE LEADS WHEN REMOVING EARPHONE FROM EARCUP.

- a. Removal.
 1. Grasp earcushion assembly (3) lengthwise and pull down and outward until earcushion assembly (3) is free from earcup shell (2).
 2. Compress earphone holder (5) containing earphone (8) and carefully pull them out of the earcup shell (2).
 3. Remove earphone (8) from pocket in earphone holder (5).
 4. Using a cross-tipped screwdriver, loosen 2 setscrews securing earphone leads to earphone (8) and separate.
 5. Compress backpad (4) and remove from earcup shell (2).

- b. Replacement
 1. With one hand compress backpad (4), with other hand spread and hold earphone leads. Insert backpad between earphone leads into earcup shell (2).
 2. Using a cross tipped screwdriver secure earphone leads to earphone (8) by tightening 2 setscrews
 3. Place earphone (8) in pocket of earphone holder (5).
 4. Compress earphone holder (5) containing earphone (8) slightly and place in ear cup shell (2).
 5. Secure one end of earcushion assembly (3) on lip of earcup shell (2) and while holding firmly in place pull other end of earcushion assembly (3) down until that end is secured on lip of earcup shell (2). Ensure earcushion assembly is secured all around earcup shell (2) lip.

3.10.4 Spring Cover Pad Removal Procedure and Replacement Procedure (Fig. 3-27)

- a. Removal
Unsnap spring cover pad (1) and remove.
- b. Replacement
Wrap spring cover pad (1) around spring assembly (6) ensuring snap side is up, and secure in place

3.10.5 Side Pad Removal and Replacement Procedures (Fig. 3-27)

- a. Removal
Press end of spring assembly (6) into side pad (7). Tilt spring assembly (6) away from side pad (7) and remove side pad (7).
- b. Replacement
Insert end of spring assembly (6) into slot on side pad (7) and secure.

SECTION IV CABLE REMOVAL AND REPLACEMENT

There are no specific procedural steps for and replacing VIS cabling. Ensure that the power is removed from the MCS prior to removing and replacing VIS cabling. Utilize the vehicle layout diagrams in Chapter 2, and if necessary the appropriate Vehicle Technical Bulletin, for the proper VIS cable routing. Additionally, when removing VIS cabling, identify the locations where the cabling is tied down or secured, when cabling is replaced the new cable is to be routed in the same manner, to stop accidental damage. Ensure that all cable tie-down locations are used and/or replaced (tie-wraps).

SECTION V LRU KNOB(s) REMOVAL AND REPLACEMENT PROCEDURES

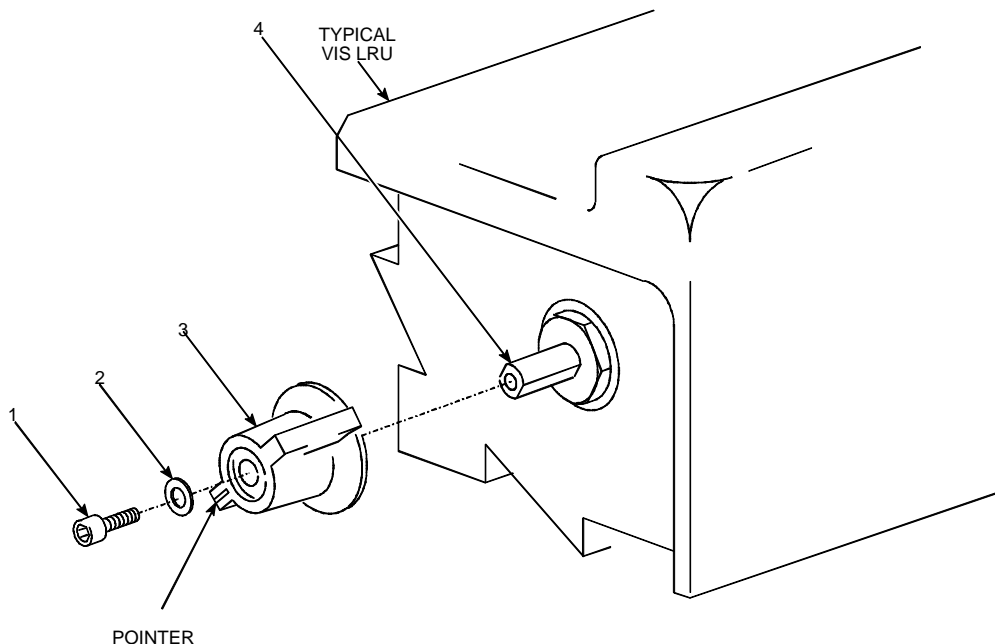

Figure 3-28. VIS LRU(s) Knob

CAUTION

WHEN REMOVING OR REPLACING KNOBS, HOLD KNOB FIRMLY WITH ONE HAND WHILE ROTATING SCREW WITH THE OTHER HAND SO AS TO NOT OVER TORQUE THE SHAFT OF THE SWITCH.

3.11. MCS, FFCS, AND MOS KNOB REMOVAL AND REPLACEMENT (Fig. 3-28)

The following procedures describe how to remove and replace control knobs on the MCS, FFCS, and MOS. The control knobs (piece parts) utilized by the MCS, FFCS, and MOS are identical

- a. Removal
 1. Turn knob to a counterclockwise position until it comes to a full stop. The luminescent pointer should be pointed down and to the left.
 2. Using a socket head screw key remove socket head screw (1) and washer (2) from shaft (4).
 3. Slide knob (3) from shaft (4).
- b. Replacement
 1. Slide knob (3) fully onto shaft (4) and turn counterclockwise until knob comes to a full stop. The luminescent pointer should be pointed down and to the left.
 2. Place washer (2) onto socket head screw (1) and install onto shaft (4).
 3. Using a socket head screw key tighten socket head screw (1) onto shaft.

3.12. LOUDSPEAKER KNOB AND MOUNTING HARDWARE REMOVAL AND REPLACEMENT PROCEDURES (Fig. 3-29)

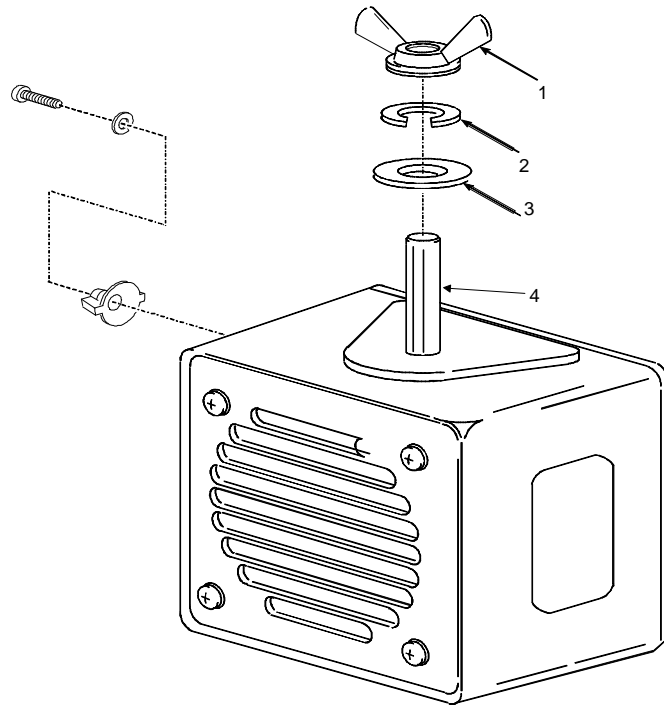

Figure 3-29. Loudspeaker Assembly

3.12.1. Loudspeaker Knob Removal and Replacement Procedure

The Knob removal and Replacement Procedures for the loudspeaker are the same as those given in the previous paragraph (3.11) for the MCS, FFCS AND MOS, with the exception that a cross head screwdriver is to be used.

3.12.2. Loudspeaker Mounting Hardware Removal and Replacement Procedure

- a. Removal
Remove wing nut (1) by turning counter-clockwise and slide lock washer (2) and flat washer (3) off threaded shaft (4).
- b. Replacement
Slide flat washer (3), lock washer (2) on threaded shaft (4), then place wing nut (1) on threaded shaft (4) and tighten by turning clockwise.

SECTION VI PREPARATION FOR STORAGE OR SHIPMENT

3.13. LRU(S) PACKAGING INSTRUCTIONS

When shipping or storing the MCS, FFCS, RIT or MOS the original or replacement LRU packaging should be used, if at all possible. The LRU(s) should be thoroughly bubble-wrapped and enclosed in an ESD package and marked as such.

3.14. HEADSET(S) PACKAGING INSTRUCTIONS

CAUTION

PRIOR TO THE CVC OR ACAPS HEADSETS BEING PACKAGED FOR STORAGE AND/OR SHIPMENT, THE AA BATTERY(S) SHOULD BE REMOVED

3.14.1. CVC Headset Packaging

The entire CVC Headset cannot be turned in for storage or shipment. Credit is only given for the Earcups and Cable Assembly component. Certain components, including personal items that have come in contact with the user, are required to be removed. The Liner; Earcushions; Front Foam Assemblies; Boom Mounting Hardware; and Microphone, Boom, and Cable Assembly should be removed prior to packaging. The Earcups and Cable Assembly should be thoroughly wiped down and cleaned with a cloth dampened, not wet, with isopropyl alcohol. The Earcups and Cable Assembly should be wrapped with bubble wrap to ensure protection for the Earphone. The AA batteries should be removed from the CVC headset.

3.14.2. ACAPS and CAPS Headset(s) Packaging

The ACAPS and CAPS headsets, specifically the earcups portion, are currently not considered a depot level repairable. When the fault lies in the electrical components of the earcups, it is recommended that the headset be cannibalized for useable parts and the remainder disposed of according to standard operating procedures (SOPs).

APPENDIX A

REFERENCES

A-1 Scope

This appendix lists all forms, field manuals, technical manuals, and miscellaneous publication used for reference in this manual.

A-2 Forms

DA Form 2028-2	Recommended Changes to Equipment Technical Publications
DA Form 2404	Equipment Inspection and Maintenance Worksheet
SF 361	Discrepancy in Shipment Report (DISREP)
SF 364	Report of Discrepancy (TDR)
SF 368	Product Quality Deficiency Report (ROD)

A-3 Field Manuals

FM 31-70	Basic Cold Weather Manual
FM 31-71	Northern Operations Manual
FM 31-72	Mountain Operations Manual

A-4 Technical Manuals

TM 3-220	Chemical, Biological, and Radiological (CBR) Decontamination Manual
TM 11-5805-201-12	Operator's and Unit Maintenance Manual for Telephone Sets, TA-312/PT and TA-312A/PT
TM 11-5820-401-10-1	VRC-12 Family of Radios, Operator's Manual (used without Intercom Systems)
TM 11-5820-401-10-2	VRC-12 Family of Radios, Operator's Manual (used with Intercom Systems)
TM 11-5820-401-20-1	VRC-12 Family of Radios, Organizational Maintenance Manual (used without Intercom Set)
TM 11-5820-401-20-2	VRC-12 Family of Radios, Organizational Maintenance Manual (used with Intercom Set AN/VIC-1(V))
TM 11-5820-890-10-3	Operator's Manual (Non-ICOM Radio Sets)
TM 11-5820-890-10-8	Operator's Manual (ICOM Radio Sets)
TM 11-5820-890-20-1	Unit Maintenance Manual (ICOM Radio Sets) (Volume 1)
TM 11-5820-890-20-2	Unit Maintenance Manual (ICOM Radio Sets) (Volume 2)
TM 11-5820-890-20-3	Unit Maintenance Manual (ICOM Radio Sets) (Volume 3 Handbook)
TM 11-5820-890-20-4	Unit Maintenance Manual (Non-ICOM Radio Sets)
TM 11-5820-923-12	Operator's and Organizational Maintenance Manual for Radio Set, AN/GRC-213
TM 11-5830-263-10	Operator's Manual Intercommunication Set AN/VIC -3(V)
TM 11-5830-263-20&P	Unit Maintenance Manual Intercommunication Set AN/VIC -3(V)
TM 746-10	General Packaging Instructions for Field Units Subscription Form
TM 750-244-2	Procedure for Destruction of Electronics Material to Prevent Enemy Use (Electronics Command)
TB 11-5830-263-20-1	Installation Instructions For Vehicular Intercommunication Set AN/VIC-3(V)1 in a Tank, Combat, Full Tracked: M1A1 Abrams
TB 11-5830-263-20-2	Installation Instructions For Vehicular Intercommunication Set AN/VIC-3(V)2 in a Tank, Combat, Full Tracked: M1A2 Abrams
TB 11-5830-263-20-3	Installation Instructions For Vehicular Intercommunication Set AN/VIC-3(V)3 in an M2A2 Bradley Fighting Vehicle

A-4 Technical Manuals (continued)

TB 11-5830-263-20-4	Installation Instructions For Vehicular Intercommunication Set AN/VIC-3(V)4 in an M3A2 Bradley Fighting Vehicle
TB 11-5830-263-20-5	Installation Instructions For Vehicular Intercommunication Set AN/VIC-3(V)5 in an M577 Command Post Vehicle
TB 11-5830-263-20-6	Installation Instructions For Vehicular Intercommunication Set AN/VIC-3(V)6 in an M109A6 Paladin Vehicle
TB 11-5830-263-20-7	Installation Instructions For Vehicular Intercommunication Set AN/VIC-3(V)7 in an M1068 SICPS Tracked Vehicle
TB 11-5830-263-20-8	Installation Instructions For Vehicular Intercommunication Set AN/VIC-3(V)8 in an S-787 SICPS Rigid Wall Shelter (RWS) Vehicle
TB 11-5830-263-20-9	Installation Instructions For Vehicular Intercommunication Set AN/VIC-3(V)9 in an M2A2 ODS Bradley Fighting Vehicle
TB 11-5830-263-20-10	Installation Instructions For Vehicular Intercommunication Set AN/VIC-3(V)10 in an M3A2 ODS Bradley Fighting Vehicle
TB 11-5830-263-20-11	Installation Instructions For Vehicular Intercommunication Set AN/VIC-3(V)11 in an Heavy Assault Bridge Vehicle
TB 11-5830-263-20-12	Installation Instructions For Vehicular Intercommunication Set AN/VIC-3(V)12 in an M992 Field Artillery Ammunition Support Vehicle
TB 11-5830-263-20-13	Installation Instructions For Vehicular Intercommunication Set AN/VIC-3(V)13 in an M7 Bradley Fire Support Team Vehicle
TB 11-5830-263-20-14	Installation Instructions For Vehicular Intercommunication Set AN/VIC-3(V)14 in an M88A2 Recovery Vehicle
TB 11-5830-263-20-15	Installation Instructions For Vehicular Intercommunication Set AN/VIC-3(V)15 in an Armored Security Vehicle
TB 11-5830-263-20-16	Installation Instructions For Vehicular Intercommunication Set AN/VIC-3(V)16 in an MLRS Vehicle
TB 11-5830-263-20-17	Installation Instructions For Vehicular Intercommunication Set AN/VIC-3(V)17 in a Grizzly (Breach) Vehicle
TB 11-5830-263-20-18	Installation Instructions For Vehicular Intercommunication Set AN/VIC-3(V)18 in a Striker Vehicle

A-5 Miscellaneous Publications

AMDF	Army Master Data File (Microfiche)
AR 55-38	Transportation Deficiency Report (TDR)
AR 380-5	Department of the Army Information Security Program Subscription Form
AR 710-2	Supply Policy Below the Wholesale Level as Contained in Unit Supply UPDATE
AR 725-50	Requisitioning, Receipt and Issuing System in UPDATE
AR 735-11-2	Report of Discrepancy (ROD)
DA PAM 25-30	Consolidated Index of Army Publications (Microfiche)
DA PAM 710-2-1	Using Unit Supply System Manual Procedures as Contained in Unit Supply UPDATE
DA PAM 738-750	Maintenance Management Update
SB 11-131-2	Vehicular Radio Sets and Authorized Installations (SINCGARS)
SB 11-573	Painting and Preservation of Supplies Available for Field Use for Electronics Command Equipment

APPENDIX B
MAINTENANCE ALLOCATION CHART (MAC)
FOR INTERCOMMUNICATION SET, VEHICULAR, AN/VIC-3(V)

SECTION I INTRODUCTION

B-1 GENERAL

- a. This section provides a general explanation of all maintenance and repair functions authorized at various maintenance categories.
- b. The Maintenance Allocation Chart (MAC) in Section II designates overall authority and responsibility for the performance of maintenance functions to the end item or component. The application of the maintenance functions to the end item or component will be consistent with the capacities and capabilities of the designated maintenance categories.
- c. Section III lists the tools and test equipment (both special tools and common tool sets) required for each maintenance function as referenced from Section II.
- d. Section IV contains supplemental instructions and explanatory notes for a particular maintenance function.

B-2 MAINTENANCE FUNCTIONS

Maintenance functions will be limited to and defined as followed:

- a. **Inspect.** To determine the serviceability of an item by comparing its physical, mechanical and/or electrical characteristics with established standards through examination (e.g. by sight, sound, or feel).
- b. **Test.** To verify serviceability by measuring the mechanical, pneumatic, hydraulic, or electrical characteristics of an item and comparing those characteristics with prescribed standards.
- c. **Service.** Operations required periodically to keep an item in proper operating condition, i.e., to clean (includes decontaminate, when required), to preserve, to drain, or to replenish fuel, lubricants, chemical fluids, or gases.
- d. **Adjust.** To maintain or regulate, within prescribed limits, by bringing into proper or exact position, or by setting the operating characteristics to specified parameters.
- e. **Align.** To adjust specified variable elements of an item to bring about optimum or desired performance.
- f. **Calibrate.** To determine and cause corrections to be made or to be adjusted on instruments or test measuring and diagnostic equipment used in precision measurement. Consists of comparisons of two instruments, one of which is a certified standard of known accuracy, to detect and adjust any discrepancy in the accuracy of the instrument being compared.

B-2 MAINTENANCE FUNCTIONS - Continued

g. Remove/Install. To remove and install the same item when required to perform service or other maintenance functions. Install may be the act of emplacing, seating, or fixing into position a spare, repair part, or module (component or assembly) in a manner to allow the proper functioning of an equipment or system.

h. Replace. To remove an unserviceable item and install a serviceable counterpart in its place. Replace is authorized by the MAC and is shown as the third position code of the SMR code.

i. Repair. The application of maintenance services¹, including fault location/troubleshooting², removal/installation, and disassembly/assembly³, procedures, and maintenance actions⁴, to identify troubles and restore serviceability to an item by correcting specific damage, fault, malfunction or failure in a part, subassembly, module (component or assembly), end item, or system.

j. Overhaul. That maintenance effort (service/action) prescribed to restore an item to a completely serviceable/operational condition as required by maintenance standards in appropriate technical publications (i.e., DMWR). Overhaul is normally the highest degree of maintenance performed by the Army. Overhaul does not normally return an item to like new condition.

k. Rebuild. Consists of those services/actions necessary for the restoration of unserviceable equipment to like new condition in accordance with original manufacturing standards. Rebuild is the highest degree of material maintenance applied to Army equipment. The rebuild operation includes the act of returning to zero those age measurements (hours/miles, etc.) considered in classifying Army equipments/components.

B-3 EXPLANATION OF COLUMNS IN THE MAC, SECTION II

(1) Group Number. Column 1 lists functional group codes numbers, the purpose of which is to identify maintenance significant components, assemblies, subassemblies, and modules with the next higher assembly. End item group number shall be "00".

(2) Component/Assembly. Column 2 contains the names of components, assemblies, subassemblies, and modules for which maintenance is authorized.

(3) Maintenance Function. Column 3 lists the functions to be performed on the item listed in column 2. (For detailed explanation of these functions, see paragraph B-2.)

¹Services - inspect, test, service, adjust, align, calibrate, and/or replace.

²Fault locate/troubleshoot - the process of investigating and detecting the cause of equipment malfunctioning, the act of isolating a fault within a system or unit under test (UUT).

³Disassembly/assembly - encompasses the step-by-step taking apart (or breakdown) of a spare/functional group coded item to the level of its least componency identified as maintenance significant (i.e., assigned a SMR code) for the category of maintenance under consideration.

⁴Actions - welding, grinding, riveting, straightening, facing, remachinery, and/or resurfacing.

B-3 EXPLANATION OF COLUMNS IN THE MAC, SECTION II (continued)

(4) Maintenance Category. Column 4 specifies, by the listing of a work time figure in the appropriate sub-column(s), the category of maintenance authorized to perform the function listed in column 3. This figure represents the active time required to perform that maintenance function at the indicated category of maintenance. If the number or complexity of the tasks within the listed maintenance function vary at different maintenance categories, appropriate work time figures will be shown for each category. The work time figure represents the average time required to restore an item (assembly, subassembly component, module, end item, or system) to a serviceable condition under typical field operating conditions. This time includes preparation time (including any necessary disassembly/assembly time), troubleshooting/fault location time, and quality assurance/quality control time in addition to the time required to perform specific tasks identified by the maintenance functions authorized in the maintenance allocation chart. The symbol designations for the various maintenance levels are as follows:

C	Operator or Crew
O	Organizational Maintenance
F	Intermediate Direct Support Maintenance
H	Intermediate General Support Maintenance
D	Depot Maintenance

(5) Tools and Equipment. Column 5 specifies, by code, those common tool sets (not individual tools) and special tools, TMDE, and support equipment required to perform the designated function.

(6) Remarks. This column shall, when applicable, contain a letter code, in alphabetic order, which shall be keyed to the remarks contained in Section IV.

B-4 EXPLANATION OF COLUMNS IN TOOL AND TEST EQUIPMENT REQUIREMENTS, SECTION III

A. Column 1, Reference code. The tool and test equipment reference code correlates with a code used in the MAC, Section II, Column 5.

B. Column 2, Maintenance Category. The lowest level of maintenance authorized to use the tool or test equipment.

C. Column 3, Nomenclature. Name or identification of the tool or test equipment.

D. Column 4, National/NATO Stock Number. The National Stock Number of the tool or TMDE.

E. Column 5, Tool Number. The manufacturer's part number.

B-5 EXPLANATION OF COLUMNS IN REMARKS, SECTION IV

A. Reference Code. The code recorded in column 6, Section II.

B. Remarks. This column lists information pertinent to the maintenance function being performed as indicated in the MAC, Section II.

**SECTION II MAINTENANCE ALLOCATION CHART
FOR INTERCOMMUNICATION SET, VEHICULAR AN/VIC-3(V)**

(1) GROUP NUMBER	(2) COMPONENT/ ASSEMBLY	(3) MAINTENANCE FUNCTION	(4) MAINTENANCE CATEGORY					(5) TOOLS AND EQPT.	(6) REMARKS
			C	O	F	H	D		
00	INTERCOMM SET, VEHICULAR AN/VIC-3(V) 1 THRU (V) 18	Inspect	0.1						A, Z
		Service	0.2						B
		Test	0.1						C
		Test		0.1				1	D
		Repair		0.2				2, 8, 10	E
01	CONTROL, INDICATOR CD-82/VRC	Inspect	0.1						A
		Repair		0.1				2	F
		Replace		0.2				2	
		Test					0.2	4, 5	G
		Repair					0.4	3, 6	H
0101	CCA (POWER)	Inspect					0.1		V
		Replace					0.2	3	
		Test					0.2	4, 5, 6	I
		Repair					0.4	3, 6, 7	J
0102	CCA (AUDIO)	Inspect					0.1		V
		Replace					0.2	3	
		Test					0.2	4, 5, 6	I
		Repair					0.4	3, 6, 7	J
02	CONTROL, INTERCOMM C-12357/VRC	Inspect	0.1						A
		Repair		0.1				2	F
		Replace		0.2				2	
		Test					0.2	4, 5	G
		Repair					0.4	3, 6	K
0201	CCA (POWER/AUDIO)	Inspect					0.1		V
		Replace					0.2	3	
		Test					0.2	4, 5, 6	I
		Repair					0.4	3, 6, 7	J

(1) GROUP NUMBER	(2) COMPONENT/ ASSEMBLY	(3) MAINTENANCE FUNCTION	(4) MAINTENANCE CATEGORY					(5) TOOLS AND EQPT.	(6) REMARKS
			C	O	F	H	D		
03	INTERFACE UNIT, COMMUNICATIONS C-12359/VRC (USED IN V5, V7, V8, V13, V18)	Inspect	0.1						A
		Replace		0.2				2, 11	
		Test					0.2	4, 5	G
		Repair					0.4	3, 6	L
0301	CCA (RADIO)	Inspect					0.1		V
		Replace					0.2	3	
		Test					0.2	4, 5, 6	I
		Repair					0.4	3, 6, 7	J
04	CONTROL, COMMUNICATIONS C-12358/VRC (USED IN V3, V9)	Inspect	0.1						A
		Repair		0.1				2	F
		Replace		0.2				2	
		Test					0.2	4, 5	M
	Repair					0.4	3, 6	N	
05	LOUDSPEAKER, PERMANENT MAGNET LS-688/VRC (USED IN V1-V14, V16, V18)	Inspect	0.1						A
		Repair		0.1				2	F
		Replace		0.2				2	
06	HEADSET, MICROPHONE H-374/VRC (USED IN V1 - V7, V9 - V18)	Inspect	0.1						A
		Service	0.1						O
		Test		0.2				2	P
		Repair		0.2				2	Q
		Replace		0.1					
0601	HEADSET, ELECTRICAL SUBASSY A3206414, A3206613	Repair		0.1					R
		Repair					*		Y
0602	MIC, BOOM, AND CABLE M175/VRC	Repair		0.1				2	S
0603	LINER, CVC	Repair		0.3					W

(1) GROUP NUMBER	(2) COMPONENT/ ASSEMBLY	(3) MAINTENANCE FUNCTION	(4) MAINTENANCE CATEGORY					(5) TOOLS AND EQPT.	(6) REMARKS
			C	O	F	H	D		
07	HEADSET, MICROPHONE H-370/VRC (USED IN V8)	Inspect Service Test Repair Replace	0.1 0.1		0.2 0.2			2, 9 2, 9	A O P U
0701	MIC, BOOM, AND CABLE ASSY, M-173/VRC	Repair		0.1				2	S
08	HEADSET ELECTRICAL, H-365/VRC (USED IN V3, V9)	Inspect Service Test Repair Replace	0.1 0.1		0.2 0.2			2 2, 9	A O P U
09	HEADSET, MICROPHONE, H-366/VRC (USED IN V3, V9)	Inspect Service Test Repair Replace	0.1 0.1		0.2 0.2			2, 9 2, 9	A O P U
0901	MIC, BOOM, AND CABLE ASSY M-172/VRC	Repair		0.1				2	S
10	HEADSET, MICROPHONE H-364/VRC (USED IN V7 & V8)	Inspect Service Test Repair Replace	0.1 0.1		0.2 0.2			2, 9 2, 9	A O P T

**SECTION III TOOLS AND TEST EQUIPMENT REQUIREMENTS
FOR INTERCOMMUNICATION SET, VEHICULAR AN/VIC-3(V)**

TOOL OR TEST EQUIPMENT REF CODE	MAINTENANCE CATEGORY	NOMENCLATURE	NATIONAL/ NATO STOCK NUMBER	TOOL NUMBER
1	O	MULTIMETER, DIGITAL AN/PSM-45A	6625-01-265-6000	
2	O	TOOL KIT, TK101/G	5180-00-064-5178	
3	D	TOOL KIT, TK100/G	5180-00-605-0079	
4	D	AN/GSM-340(V)2 (CEE)	6625-01-295-2509	
5	D	TEST PROGRAM SET, VIS CEE	--	A31U18385
6	D	ESD WRIST STRAP	5920-01-301-0424	4001829
7	D	SOLDER/DESOLDER STATION	3439-01-317-2850	CRAFT 25
8	O	SCREWDRIVER, CROSS-TIP	5120-00-234-8912	SSDP63
9	O	SCREWDRIVER, CROSS-TIP	5120-00-060-2004	7228423P1
10	O	SOCKET, WRENCH	5120-00-227-6705	
11	O	WRENCH, SPANNER	5120-00-264-3777	39-4815
12	O	PLIERS, SLIP JOINT	5120-01-336-5636	420

**SECTION IV REMARKS
FOR AN/VIC-3(V) VEHICULAR INTERCOMMUNICATION SET**

Reference Code **	Remarks
A	VISUALLY INSPECT INDIVIDUAL COMPONENTS (MCS, FFCS, RIT, MOS, LOUDSPEAKER, HEADSETS AND BAILOUT CABLES) FOR DAMAGE. CHECK SYSTEM CABLES FOR CRACKS, WORN SPOTS AND LOOSE/BENT/BROKEN PINS. CHECK LOCKNUTS OF CABLE RECEPTACLES FOR PROPER TIGHTNESS. CHECK FOR INSTALLATION OF DUST COVERS ON UNUSED RECEPTACLES. CHECK MOUNTING HARDWARE FOR TIGHTNESS.
B	SERVICING OF EQUIPMENT CONSISTS OF CLEANING ALL EXTERIOR SURFACES (TO INCLUDE RECEPTACLES AND CONNECTORS) WITH A CLEAN CLOTH OR WITH A CLEAN CLOTH DAMPENED (NOT WET) WITH DEGREASING SOLVENT OR ISOPROPYL ALCOHOL. ADDITIONALLY, THE EQUIPMENT CAN BE WASHED DOWN WITH WATER HOSE PROVIDED WATER IS NOT SPRAYED DIRECTLY AT FRONT PANELS AND CONNECTORS. WIPE THE EQUIPMENT DRY AFTER USING A WATER HOSE.
C	PERFORM BIT ERROR CODE INDICATIONS TO VERIFY SYSTEM OPERATION CAPABILITY. FOR BIT OPERATION INSTRUCTIONS REFER TO TM 11-5830-263-10.
D	PERFORM BIT AND/OR MANUAL TESTING TO FAULT ISOLATE TO MCS, FFCS, RIT, MOS, LOUDSPEAKER, HEADSETS, BAILOUT CABLES, AND SYSTEM CABLES.
E	INCLUDES REPLACEMENT OF DEFECTIVE MCS, FFCS, RIT, MOS, LOUDSPEAKER, HEADSETS, BAILOUT CABLES AND SYSTEM CABLES.
F	REPAIR AT ORGANIZATIONAL LEVEL IS LIMITED TO REMOVAL AND REPLACEMENT OF DEFECTIVE KNOBS.
G	FAULT ISOLATE TO CCA(S) AND FLEX CCA(S).
H	INCLUDES REMOVAL/REPLACEMENT OF THE POWER CCA, AUDIO CCA, RADIO FLEX CCA, AND POWER/DISPLAY FLEX CCA.
I	FAULT ISOLATE TO DEFECTIVE PIECE PARTS.
J	REMOVE AND REPLACE DEFECTIVE PIECE PARTS
K	INCLUDES REMOVAL AND REPLACEMENT OF THE POWER/AUDIO CCA, AND THE HIGHWAY AND INTERCONNECT FLEX CCA.
L	INCLUDES REPLACEMENT OF THE POWER CCA, HIGHWAY AND POWER FLEX CCA.
M	FAULT ISOLATE TO FLEX CCA(S).
N	INCLUDES REMOVAL AND REPLACEMENT OF THE AUDIO AND HIGHWAY FLEX CCA.
O	SERVICING HEADSETS CONSISTS OF CLEANING WITH A CLEAN CLOTH DAMPENED (NOT WET) WITH GENERAL PURPOSE CLEANER OR ISOPROPYL ALCOHOL. LINERS, IF PRESENT, MAY BE WASHED USING A GENERAL PURPOSE DETERGENT (LINER PADS SHOULD BE REMOVED PRIOR TO WASHING).
P	MANUALLY FAULT ISOLATE BY SUBSTITUTION TO IDENTIFY DEFECTIVE PIECE PARTS.
Q	INCLUDES REMOVAL AND REPLACEMENT OF ELECTRICAL HEADSET; LINER; MIC, BOOM, AND CABLE ASSEMBLY; AND BOOM MOUNTING HARDWARE.
R	INCLUDES REMOVAL AND REPLACEMENT OF EARCUSHION AND FRONT FOAM ASSEMBLY; OR THE EARSEAL, DAMP COVER, AND FOAM DAMPER. INCLUDES REMOVAL AND REPLACEMENT OF SWITCH COVERS AND BATTERY COVER, IF PRESENT. INCLUDES REMOVAL AND REPLACEMENT OF RECHARGEABLE OR AA ALKALINE BATTERY IN PICVC.

Reference Code **	Remarks
S	INCLUDES REMOVAL AND REPLACEMENT OF THE O-RING AND MICROPHONE SHIELD (IF PRESENT), MICROPHONE (INCLUDING SETSCREWS), MICROPHONE CABLE ASSEMBLY, MICROPHONE CLIP, AND BOOM ASSEMBLY (INCLUDING THUMBSCREW/NYLOCK SCREW).
T	INCLUDES REMOVAL AND REPLACEMENT OF MICROPHONE (INCLUDING SET SCREWS), MICROPHONE CLIP, BOOM MOUNTING HARDWARE KIT, BOOM ASSEMBLY (INCLUDING THUMBSCREW/NYLOCK SCREW), SPRING ASSEMBLY COVER PAD, EARSEAL, EARPHONE HOLDER, EARPHONE AND BACK PAD.
U	INCLUDES REMOVAL AND REPLACEMENT OF ELECTRICAL HEADSET (OR ELECTRICAL HEADSET SUBASSEMBLY), SPRING ASSEMBLY AND ATTACHING HARDWEAR, OVERHELMET STRAP AND ATTACHING HARDWARE, AND NECKBAND COVER. ALSO INCLUDES REMOVAL AND REPLACEMENT OF BOOM MOUNTING HARDWEAR, AND MICROPHONE, BOOM, AND CABLE ASSEMBLY, IF PRESENT, OR THE SOCKET BLANKING PLUG, IF NOT. INCLUDES REMOVAL AND REPLACEMENT OF AA ALKALINE BATTERY (ACAPS ONLY)
V	INSPECT FOR PHYSICAL DAMAGE.
W	INCLUDES REMOVAL AND REPLACEMENT OF LINER PADS. THE CVC LINER WILL UTILIZE THE PADS IN THE PICVC LINER AS REPLACEMENTS. THE REPLACEMENT PADS COME IN SETS, LARGE AND MEDIUM/SMALL
Y	INTERNAL COMPONENTS OF ELECTRICAL HEADSETS/HEADSET SUBASSEMBLIES REQUIRE DEPOT LEVEL REPAIR.
Z	THERE ARE CURRENTLY 18 VARIATIONS OF THE AN/VIC-3. THE VARIATIONS ARE AS FOLLOWS: (V)1-M1A1 ABRAMS, (V)2-M1A2 ABRAMS, (V)3-M2A2 BRADLEY, (V)4-M3A2 BRADLEY, (V)5-M577COMM. POST, (V)6-M109A6, PALADIN, (V)7-SICPS TRACK, (V)8- SICPS SHELTER, (V)9- M2A2 ODS BRADLEY, (V)10 M3A2 ODS BRADLEY, (V)11 HEAVY ASSAULT BRIDGE, (V)12 M992 FIELD ARTILLERY AMMUNITION SUPPORT VEHICLE, (V)13 M7 BRADLEY FIRE SUPPORT TEAM VEHICLE, (V)14 M88A2 RECOVERY VEHICLE, (V)15 ARMORED SECURITY VEHICLE, (V)16 MULTIPLE LAUNCH ROCKET SYSTEM, (V)17 GRIZZLY (BREACHER), (V)18 STRIKER.

** REFERENCE CODE "X" IS NOT USED

APPENDIX C
UNIT MAINTENANCE
REPAIR PARTS AND SPECIAL TOOLS LIST (RPSTL)

TABLE OF CONTENTS

			Page	Illus/ Figure
Section	I	Introduction	C-2	
	II	Repair Parts List	C-1-1	
Group	00	Intercommunication Set, Vehicular AN/VIC-3(V)1-(V)18	C-1-1	C-1
	01	Control, Intercommunication System CD-82/VRC	C-2-1	C-2
	02	Intercommunication Station C-12357/VRC	C-3-1	C-3
	04	Monitor, Audio Frequency C-12358/VRC	C-4-1	C-4
	05	Loudspeaker, Permanent Magnet LS-688/VRC	C-5-1	C-5
	06	Headset, Microphone H-374(V)1, (V)2, (V)3, (V)4, (V)5/VRC	C-6-1	C-6
	0601	Headset, Electrical Assembly	C-7-1	C-7
	0602	Microphone, Boom and Cable Assembly	C-8-1	C-8
	0603	Liner, CVC	C-9-1	C-9
	07	Headset, Microphone H-370/VRC	C-10-1	C-10
	0701	Microphone, Boom and Cable Assembly M-173/VRC	C-11-1	C-11
	08	Headset, Electrical Assembly H-365/VRC	C-12-1	C-12
	09	Headset, Microphone H-366/VRC	C-13-1	C-13
	0901	Microphone, Boom and Cable Assembly M-172/VRC	C-14-1	C-14
	10	Headset, Microphone H-364/VRC	C-15-1	C-15
Section	III	Special Tools List (not applicable)		
	IV	Cross Reference Indexes	C-I-1	
		National Stock Number Index	C-I-1	
		Part Number Index	C-I-4	

SECTION I

INTRODUCTION

C-1 SCOPE

This manual lists and authorizes spares and repair parts; special tools; special test, measurement, and diagnostic equipment (TMDE); and other special support equipment required for the performance of Unit Maintenance of the AN/VIC-3(V)1 through AN/VIC-3(V)18. It authorizes the requisitioning, issue and disposition of spares, repair parts and special tools as indicated by the source, maintenance and recoverability (SMR) codes.

C-2 GENERAL

In addition to Section I, Introduction, this Repair Parts and Special Tools List is divided into the following sections:

- a. *Section II, Repair Parts List.* A list of spares and repair parts authorized by the RPSTL for use in the performance of maintenance. This list also includes parts that must be removed for replacement of the authorized parts. Parts lists are composed of functional groups in ascending alphanumeric sequence, with the parts in each group listed in ascending item number sequence. Figure numbers are listed directly beneath the group header. Bulk materials are listed in item name sequence. Repair part kits are listed separately in their own functional group within Section II. Repair parts for repairable special tools are also listed in this section. Items listed are shown on the associated illustration.
- b. *Section III, Special Tools List.* Not applicable. There are no special tools required in the maintenance of the AN/VIC-3(V) 1 through AN/VIC-3(V)18.
- c. *Section IV, Cross Reference Indexes.* A list, in National item identification number (NIIN) sequence, of all National stock numbered items appearing in the listing, followed by a list in alphanumeric sequence of all part numbers appearing in the listings. National stock numbers and part numbers are cross-referenced to each illustration figure and item number appearance. The figure number and item number index lists figure and item numbers in numeric sequence and cross-references National stock number, Commercial and Government Entity Code and part numbers.

C-3 EXPLANATION OF COLUMNS (Section II and III)

- a. *Item No. (Column 1).* Indicates the number used to identify items called out in the illustration.
- b. *SMR Code (Column 2).* The source, maintenance, and recoverability (SMR) code is a five position code containing supply/requisitioning information, maintenance category authorization criteria and disposition instruction, as shown in the following breakout:

Source Code XX	Maintenance Code		Recoverability Code X
1 st two positions	X	X	5 th position
How you get an item	3 rd position	4 th position	5 th position
	Who can install, replace or use the item	Who can do complete repair (see note below) on the item	Who determines disposition action on an unserviceable item

NOTE

Complete repair: Maintenance capacity, capability, and authority to perform all corrective maintenance tasks of the “repair” function in a use/user environment in order to restore serviceability to a failed item.

1. *Source Code.* The source code tells you how to get an item needed for maintenance, repair or overhaul of an end item/equipment. Explanations of source codes follows:

Code	Explanation
PA PB PC PD PE PF PG	Stocked items: use the applicable NSN to request/requisition items with these source codes. They are authorized to the level indicated by the code entered in the third position of the SMR code. NOTE Items coded PC are subject to deterioration.
KD KB KF	Items coded with these codes are not to be requested/requisitioned individually. They are part of a kit which is authorized to the maintenance category indicated in the third position of the SMR code. The complete kit must be requisitioned and applied.
MO - Made at unit/AVUM category MF - Made at DS/AVIM category MH - Made at GS category ML - Made at Specialized Repair Activity (SRA) MD - Made at Depot	Items with these codes are not to be requested/requisitioned individually. They must be made from built material which is identified by the part number in the description and usable on code (UOC) column and listed in the Bulk Material group of the repair parts list. If the item is authorized to you by the third position code of the SMR code, but the source code indicates it is made at a higher category, order the item from the higher category of maintenance.
AO - Assembled by unit/AVUM category AF - Assembled by DS/AVIM category AH - Assembled by GS category AL - Assembled by SRA AD - Assembled by Depot	Items with these codes are not to be requested/requisitioned individually. The parts that make up the assembled item must be requisitioned or fabricated and assembled at the category of maintenance indicated by the source code. If the third position code of the SMR code authorizes you to replace the item, but the source code indicates the item is assembled at a higher category, order the item from the higher category of maintenance.

Code	Application/Explanation
XA -	Do not requisition an "XA" coded item. Order its next higher assembly. (Also refer to Note below.)
XB -	If an "XB" item is not available from salvage, order it using the CAGEC and part number given.
XC -	Installation drawing, diagram, instruction sheet, field service drawing, that is identified by manufacturer's part number.
XD -	Item is not stocked.. Order an "XD" coded item through normal supply channels using the CAGEC and part number given, if no NSN is available.

NOTE

Cannibalization or controlled exchange, when authorized, may be used as a source of supply for items with the above source codes, except for those source coded "XA" or those aircraft support items restricted by requirements of AR 750-1

2. *Maintenance code.* Maintenance codes tell you the category of maintenance authorized to USE and REPAIR support items. The maintenance codes are entered in the third and fourth positions of the SMR code as follows:

- (a) The maintenance code entered in the third position tells you the lowest maintenance category authorized to remove, replace, and use an item. The maintenance code entered in the third position will indicate authorization to one of the following categories of maintenance.

Code Application/Explanation

- C - Crew or operator maintenance done within unit or aviation maintenance.
- O - Unit or aviation unit category can remove, replace, and use the item.
- F - Direct support or aviation intermediate category can remove, replace, and use the item.
- H - General support category can remove, replace, and use the item.
- L - Specialized repair activity can remove, replace, and use the item.
- D - Depot category can remove, replace, and use the item

- (b) The maintenance code entered in the fourth position tells whether or not the item is to repaired and identifies the lowest maintenance category with the capability to do complete repair (i.e., perform all authorized repair functions). This position will contain one of the following maintenance codes.

NOTE

Some limited repair may be done on the item at a lower category of maintenance, if authorized by the Maintenance Allocation Chart (MAC) and SMR codes.

Code	Application/Explanation
O -	Unit or aviation unit is the lowest category that can do complete repair of the item
F -	Direct support or aviation intermediate is the lowest category that can do complete repair of the item
H -	General support is the lowest category that can do complete repair of the item
L -	Specialized repair activity (designate the specialized repair activity) is the lowest category that can do complete repair of the item
D -	Depot is the lowest category that can do complete repair of the item
Z -	Non repairable. No repair is authorized.
B -	No repair is authorized. (No parts or special tools are assigned for the maintenance of a "B" coded item.) However, the item may be reconditioned by adjusting, lubricating, etc., at the user category.

3. *Recoverability code.* Recoverability codes are assigned to items to indicate the disposition action on unserviceable items. The recoverability code is entered in the fifth position of the SMR code as follows:

Code	Application/Explanation
Z -	Non repairable item. When unserviceable, condemn and dispose of the item at the category of maintenance shown in the third position of SMR code.
O -	Repairable item. When uneconomically repairable, condemn and dispose of the item at unit or aviation unit category
F -	Repairable item. When uneconomically repairable, condemn and dispose of the item at direct support or aviation intermediate category
H -	Repairable item. When uneconomically repairable, condemn and dispose of the item at general support category
D -	Repairable item. When beyond lower category repair capability, return to depot. Condemnation and disposal of item not authorized below depot category.
L -	Repairable item. Condemnation and disposal not authorized below specialized repair activity (SRA).
A -	Item requires special handling or condemnation procedures because of specific reasons (e.g., precious metal content, high dollar value, critical material, or hazardous material. Refer to appropriate manuals/directives for specific instructions.

- c. *NSN (Column 3).* Indicates the national stock number assigned to the manufacturer's part number. The national stock number consists of 13 digits.
- d. *CAGEC (Column 4).* The Commercial and Government Entity Code (CAGEC) is a 5-digit numeric code which is used to identify the manufacturer, distributor, or Government agency, etc., that supplies the item.
- e. *Part Number (Column 5).* Indicates the primary number used by the manufacturer (individual, company, firm, corporation, or Government activity), which controls the design and characteristics of the item by means of its engineering drawings, specifications, standards, and inspection requirements to identify an item or range of items.

NOTE

When you use an NSN to requisition an item, the item you receive may have a different part number from the part ordered.

- f. *Description and Usable on Code (UOC) (Column 6)*. This column includes the following information.
 - 1. The Federal item name and, when required, a minimum description to identify the item.
 - 2. The physical security classification of the item is indicated by the parenthetical entry (insert applicable physical security classification abbreviation, e.g., Phy Sec C1 - Confidential, Phy Sec C1 (S) – Secret, Phy Sec C1 (T) –Top Secret).
 - 3. Items that are included in kits and sets are listed below the name of the kit or set.
 - 4. Spare/repair parts that make up an assembled item are listed immediately following the assembled item line entry.
 - 5. Part numbers for built materials are referenced in this column in the line entry for the item to be manufactured/fabricated.
 - 6. When the item is not used with all serial numbers of the same model, the effective serial numbers are shown on the last line of the description (before UOC).
 - 7. Usable on code when applicable (para. 5).
 - 8. In the Special Tools section, the basis of issue (BOI) appears as the last line in the entry for each special tool, special TMDE, and other special support equipment. When density of equipments supported exceeds density spread indicated in the basis of issue, the total authorization is increased proportionately.
 - 9. The statement “END OF FIGURE” appears just below the last item description in Column 5 for a given figure in both Section II and Section III.
- g. *Qty (Column 7)*. Indicates the quantity of the item used in the breakout shown on the illustration figure, which is prepared for a functional group, sub functional group, or an assembly. A “V” appearing in this column instead of a quantity indicates that the quantity is variable and the quantity may vary from application to application.

C-4 EXPLANATION OF COLUMNS (Section IV)

- a. National Stock Number (NSN) Index.
 - 1. *Stock number column*. This column lists the NSN by National item identification number (NIIN) sequence. The NIIN consists of the last nine digits of the NSN. When using this column to locate an item, ignore the first four digits of the NSN. When requisitioning items use the complete NSN (13-digit) sequence.
 - 2. *Fig. column*. This column lists the number of the figure where the item is identified/located. The illustrations are in numerical sequence in Sections II and III.
 - 3. *Item column*. The item number identifies the item associated with the figure listed in the adjacent Fig. column. This item is also identified by the NSN listed on the same line.
- b. Part Number Index. Part numbers in this index are listed by part number in ascending alphanumeric sequence.
 - 1. Identified/located in Sections II and III.
 - 2. *Item column*. The item number is that number assigned to the item as it appears in the figure referenced in the adjacent figure number column.

- c. Figure and Item Number Index.
 1. *Fig. column.* This column lists the number of the figure where the item is identified/located in Sections II and III.
 2. *Item column.* The item number is that number assigned to the item as it appears in the figure referenced in the adjacent figure number column.
 3. *Stock number column.* This column lists the National stock number for the item.
 4. *CAGEC column.* The Commercial and Government Entity Code (CAGEC) is a 5-digit numeric code used to identify the manufacturer, distributor, or Government agency, etc, that supplies the item.
 5. *Part number column.* Indicates the primary number used by the manufacturer (individual, fir, corporation, or Government activity), which controls the design and characteristics of the item by means of its engineering drawings, specifications, standards, and inspection requirements to identify an item or range of items.

C-5 SPECIAL INFORMATION

- a. *Usable on Code.* The usable on code appears in the lower left corner of the description column heading. Usable on codes are shown as "UOC". In the description column (justified left) on the first line applicable item description nomenclature. Uncoded items are applicable to all models. Identification of the usable on codes used in this RPSTL are:

Code	Used On
KDQ	AN/VIC-3(V)1
KDR	AN/VIC-3(V)2
KDS	AN/VIC-3(V)3
KDT	AN/VIC-3(V)4
KDU	AN/VIC-3(V)5
KDV	AN/VIC-3(V)6
KDW	AN/VIC-3(V)7
KDX	AN/VIC-3(V)8
LHL	AN/VIC-3(V)9
LHM	AN/VIC-3(V)10
LUY	AN/VIC-3(V)11
LUZ	AN/VIC-3(V)12
LVA	AN/VIC-3(V)13
LVB	AN/VIC-3(V)14
LVC	AN/VIC-3(V)15
LVD	AN/VIC-3(V)16
LVE	AN/VIC-3(V)17
23C	AN/VIC-3(V)18

- b. *Fabrication Instructions.* The AN/VIC-3(V)1 through (V)18 require no bulk materials for fabrication.
- c. *Assembly Instructions.* The AN/VIC-3(V)1 through (V)18 require no assembly instructions.
- d. *Kits.* The AN/VIC-3(V)1 through (V)18 require no repair parts kits.
- e. *Index Numbers.* AN/VIC-3(V)1 through (V)18 require no bulk items requiring index numbers.

TM 11-5830-263-20&P

- f. *Associated Publications.* The publications listed below pertain to the AN/VIC-3(V)1 through (V)18 and their components:
- TM 11-5830-263-10
TB 11-5830-263-20-1 through TB 11-5830-263-20-20
- g. *Illustrations – Listing.* Only those parts coded “C” or “O” in the third position of the SMR code are listed in the tabular listing; therefore, there may be a break in the item number sequence, figure number and page number. Only illustrations containing unit authorized items appear in this RPSTL.
- h. *National Stock Numbers.* National stock numbers (NSNs) that are missing from “P” source coded items have been applied for and will be added to this TM by future change/revision when they are entered in the Army Master Data File (AMDF). Until the NSNs are established and published, submit exception requisitions to: Commander, US Army Communications-Electronics Command and Fort Monmouth, ATTN: AMSEL-LC-MM, Fort Monmouth, NJ 07703-5007 for the part required to support your equipment.

C-6 HOW TO LOCATE REPAIR PARTS

- a. When National stock number or part number is not known.
1. *First.* Using the table of contents, determine the assembly group or subassembly group to which the item belongs. This is necessary since figures are prepared for assembly groups and subassembly groups, and listings are divided into the same groups.
 2. *Second.* Find the figure covering the assembly group or subassembly group to which the item belongs.
 3. *Third.* Identify the item on the figure and note the item number.
 4. *Fourth.* Refer to the Repair Parts Lists for the figure to find the part number for the item number noted on the figure.
 5. *Fifth.* Refer to the Part Number index to find the NSN, if assigned.
- b. When National stock number or part number is known.
1. *First.* Using the index of National stock numbers and part numbers, find the pertinent National stock number or part number. The NSN index is in National item identification number (NIIN) sequence (para. C-4a1). The part numbers in the part number index are listed in ascending alphanumeric sequence (para. C-4b). Both indexes cross-reference you to the illustration figure and item number of the item you are looking for.
 2. *Second.* After finding the figure and item number, verify that the item is the one you’re looking for, then locate the item number in the repair parts list for the figure.

C-7 ABBREVIATIONS

Not applicable

SECTION II – REPAIR PARTS LIST

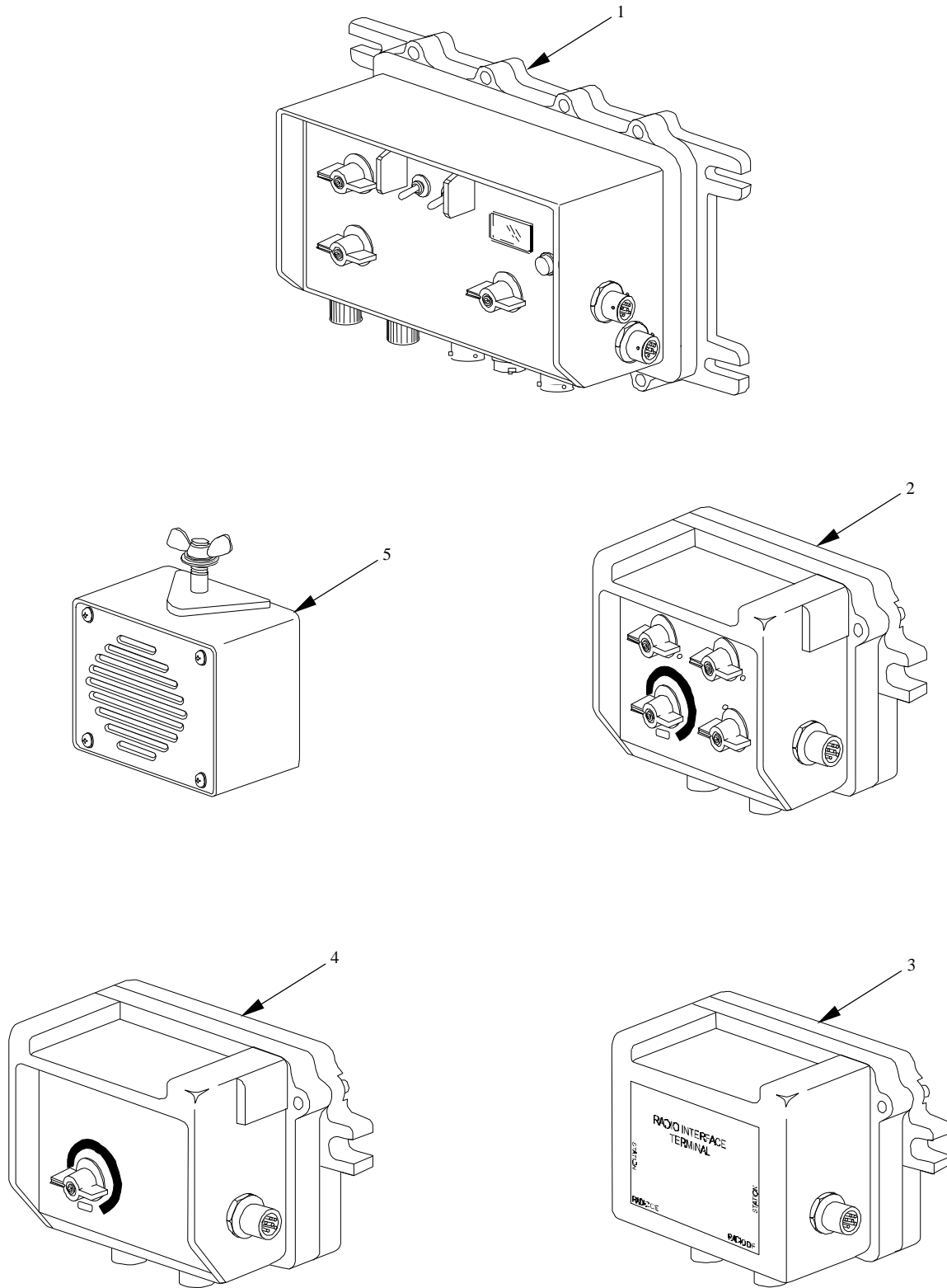

Figure 1. Intercommunication Set, Vehicular AN/VIC-3(V) (Sheet 1 of 11)

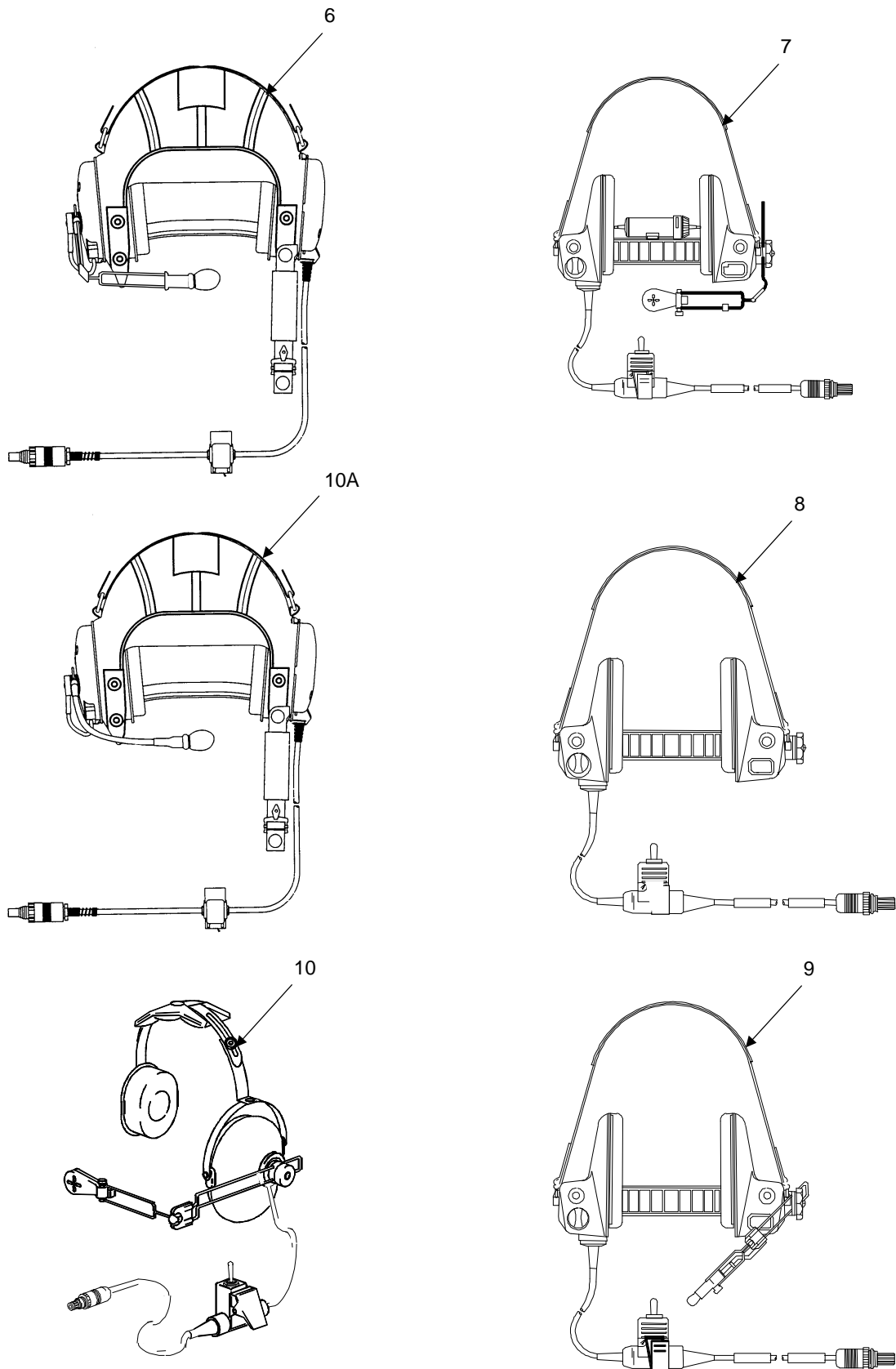

Figure 1. Intercommunication Set, Vehicular AN/VIC-3(V) (Sheet 2 of 11)

11. Cable Assemblies

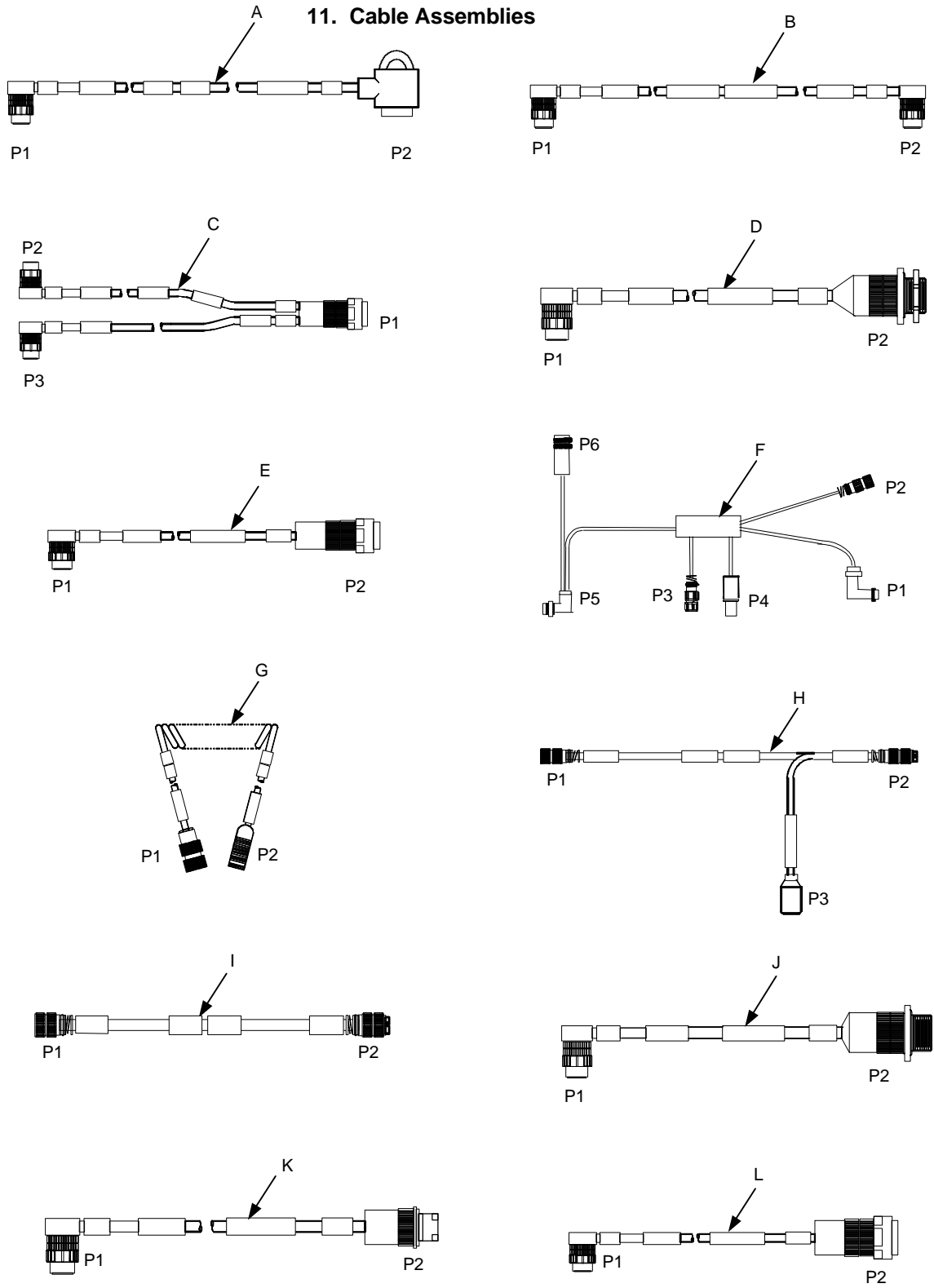

Figure 1. Intercommunication Set, Vehicular AN/VIC-3(V) (Sheet 3 of 11)

11. Cable Assemblies

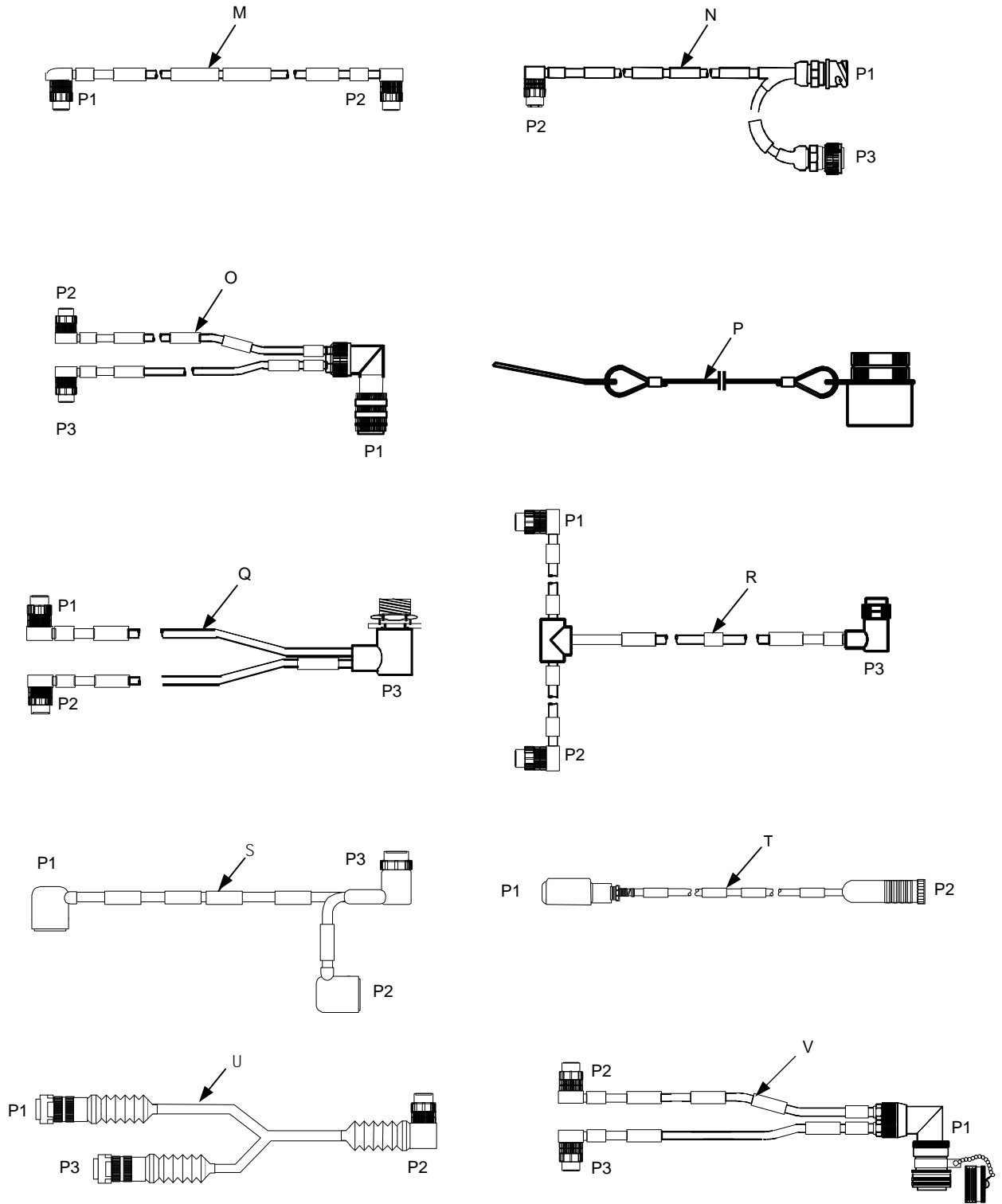

Figure 1. Intercommunication Set, Vehicular AN/VIC-3(V) (Sheet 4 of 11)

MCS Mounting Hardware

VEHICLE (AN/VIC-3(V))	SEQ
M1A1 ABRAMS ((V)1), M1A2 ABRAMS ((V)2)	A
M2A2 BRADLEY ((V)3), M3A2 BRADLEY ((V)4)	B
M577 COMMAND POST ((V)5)	H
M109A6 PALADIN ((V)6)	C
M1068 SICPS TRACKED ((V)7)	H
S-787 SICPS RIGID WALL ((V)8)	E
M2A2 ODS BRADLEY ((V)9), M3A2 ODS BRADLEY ((V)10)	B
HAB ((V)11)	F
M992 FAASV ((V)12)	I
M7 BFIST ((V)13)	D
M88A2 RECOVERY ((V)14)	K
ASV ((V)15)	J
MLRS ((V)16)	L
GRIZZLY (BREACHER) ((V)17)	G
STRIKER ((V)18)	M

Figure 1. Intercommunication Set, Vehicular AN/VIC-3(V) (Sheet 5 of 11)

FFCS Mounting Hardware

VEHICLE (AN/VIC-3(V))	POSITION FFCS MOUNTED IN	SEQ
M1A1 ABRAMS ((V)1), M1A2 ABRAMS ((V)2)	COMMANDER, GUNNER, LOADER	K
	DRIVER	A
M2A2 BRADLEY ((V)3)	COMMANDER, GUNNER, DRIVER, TEAM LEADER, SQUAD LEADER	N
	FORWARD OBSERVER/RADIO TELEPHONE OPERATOR	P
M3A2 BRADLEY ((V)4)	ALL	N
M577 COMMAND POST ((V)5)	COMMANDER, DRIVER, ROADSIDE OPERATOR (#1, #2, #3)	O
M109A6 PALADIN ((V)6)	SECTION CHIEF, CANNONEER, GUNNER, AUXILIARY	B
	EXTERNALLY MOUNTED, DRIVER	D
M1068 SICPS TRACKED ((V)7)	COMMANDER, OPERATOR #1	O
	DRIVER, OPERATOR #2	C
S-787 SICPS RIGID WALL ((V)8)	DRIVER, PASSENGER, OPERATOR #1	F
	OPERATOR #2	Q
M2A2 ODS BRADLEY ((V)9)	COMMANDER, MACHINE GUNNER, GUNNER	R
	FIRE TEAM LEADER	E
	DRAGON GUNNER	G
	DRIVER	AB
M3A2 ODS BRADLEY ((V)10)	COMMANDER, GUNNER, ROADSIDE CEILING SOLDIER, DRIVER	R
	ROADSIDE SOLDIER	S
HAB ((V)11)	COMMANDER, DRIVER	H
M992 FAASV ((V)12)	COMMANDER, DRIVER, REAR CREWMEMBER	T
M7 BFIST ((V)13)	COMMANDER, DRIVER, FSSgt	U
	SPARE	V
	FIRE SUPPORT SPECIALIST (Note: Ground cable supplied by vehicle)	W
M88A2 RECOVERY ((V)14)	COMMANDER, DRIVER, MECHANIC, SPARE	Y
ASV ((V)15)	COMMANDER, DRIVER,	X
	PASSENGER	I
	GUNNER	L
MLRS ((V)16)	CHIEF, GUNNER, DRIVER	Z
GRIZZLY (BREACHER) ((V)17)	DRIVER	J
	COMMANDER	M
STRIKER ((V)18)	DRIVER, TURRET, OPERATOR	AA

Figure 1. Intercommunication Set, Vehicular AN/VIC-3(V) (Sheet 7 of 11)

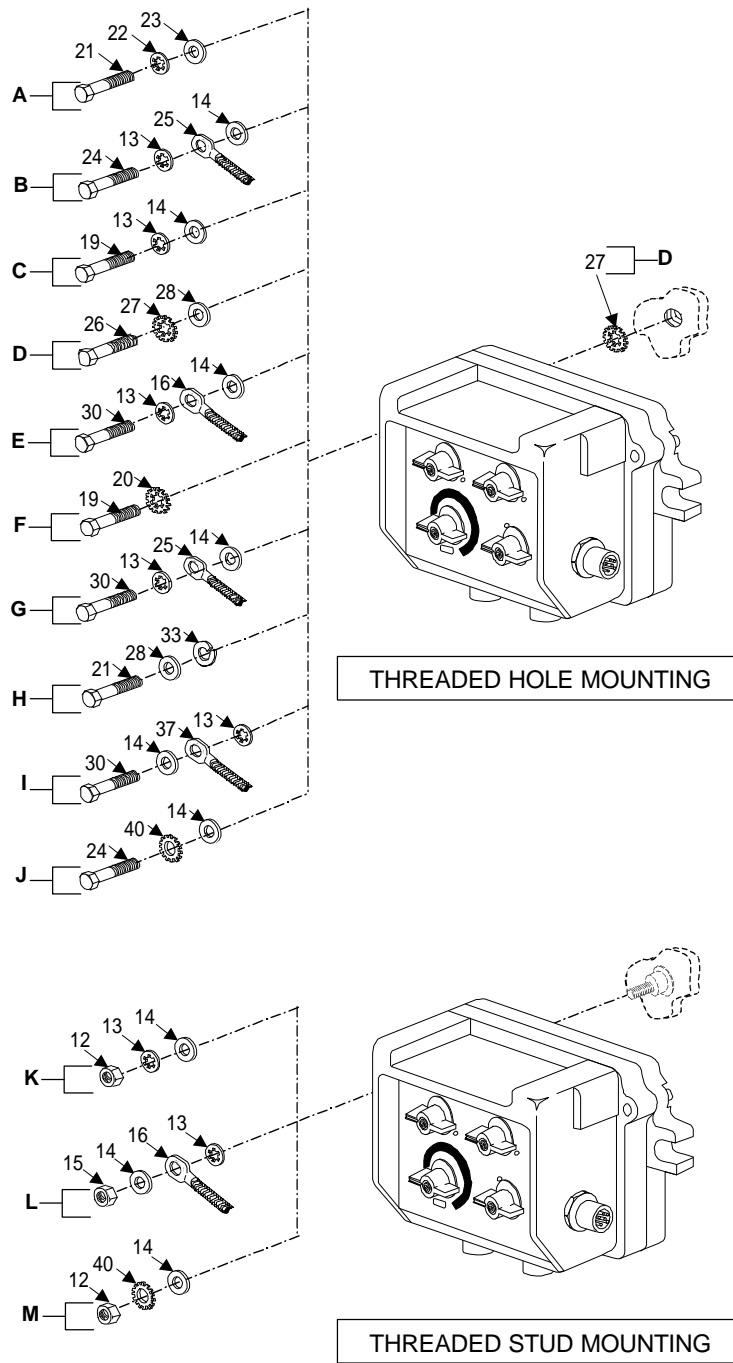

FFCS MOUNTING HARDWARE (Part I of II)

Figure1. Intercommunication Set, Vehicular AN/VIC-3(V) (Sheet 8 of 11)

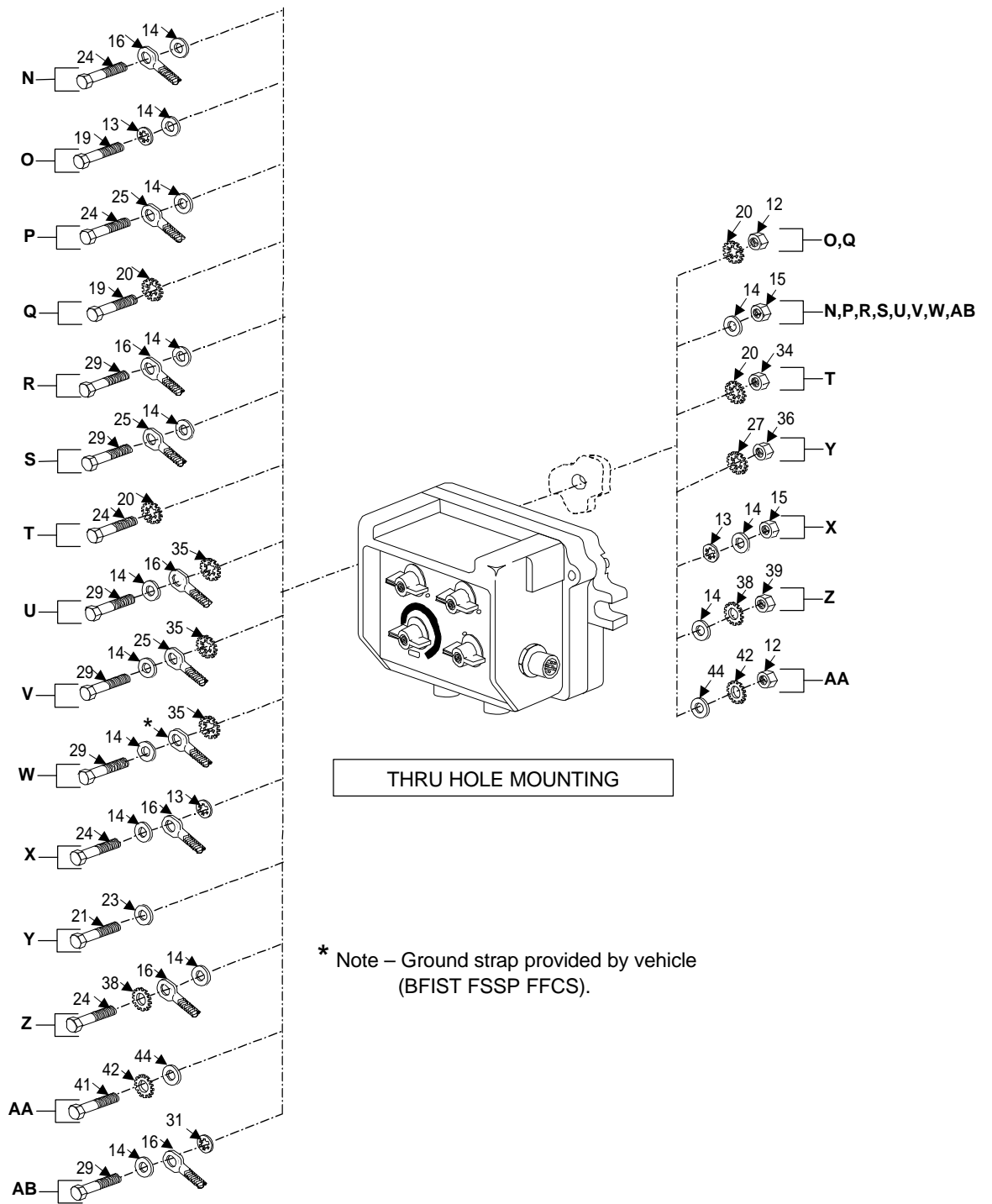

FFCS MOUNTING HARDWARE (Part II of II)

Figure1. Intercommunication Set, Vehicular AN/VIC-3(V) (Sheet 9 of 11)

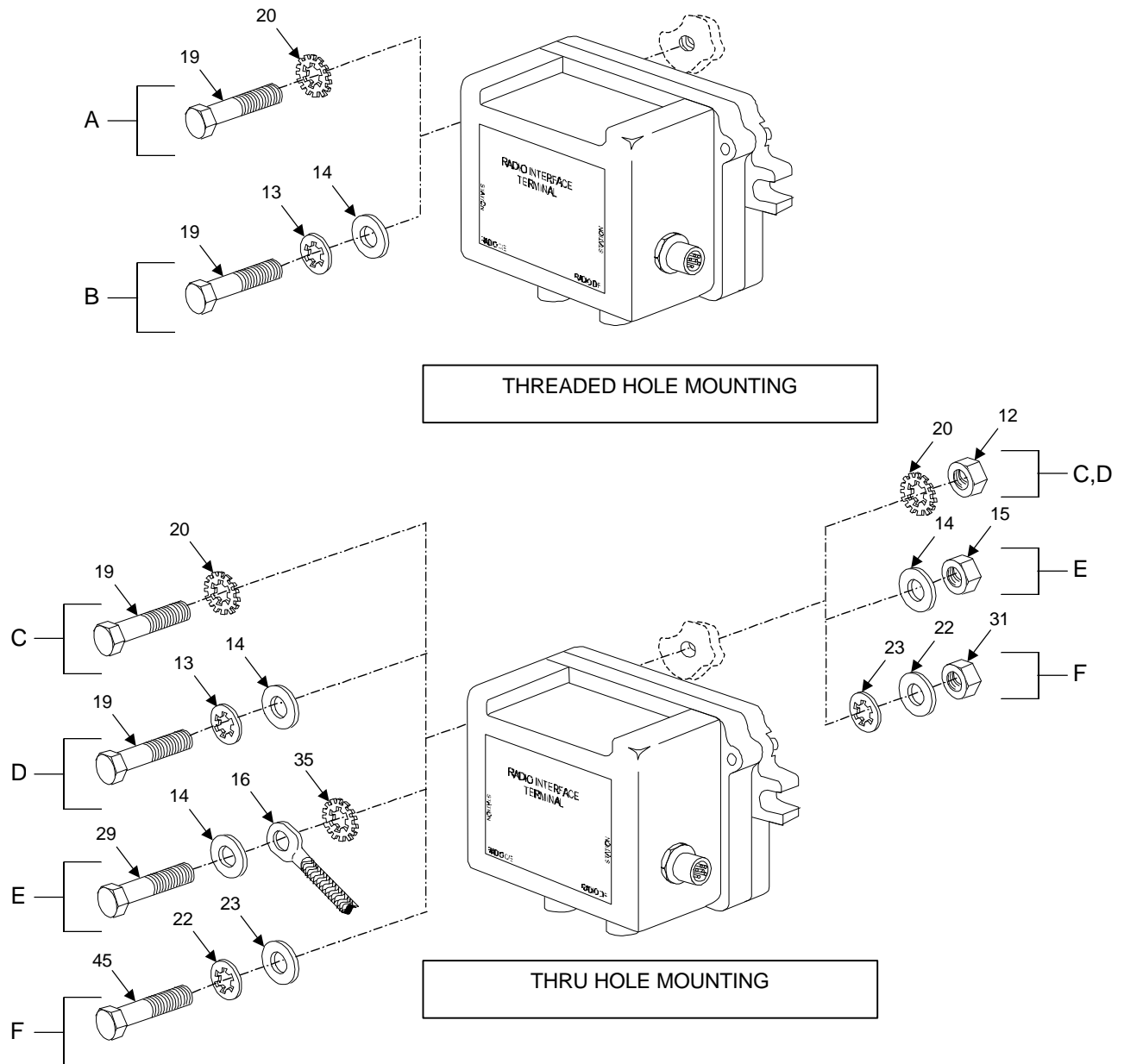

RIT Mounting Hardware

VEHICLE (AN/VIC-3(V))	POSITION RIT MOUNTED IN VEHICLE	SEQ
M577 COMMAND POST ((V)5)		D
M1068 SICPS TRACKED ((V)7)	RIT #1, RIT #2	B
S-787 SICPS RIGID WALL ((V)8)	RIT #1	C
	RIT #2	A
M7 BFIST ((V)13)		E
STRIKER ((V)18)		F

Figure 1. Intercommunication Set, Vehicular AN/VIC-3(V) (Sheet 10 of 11)

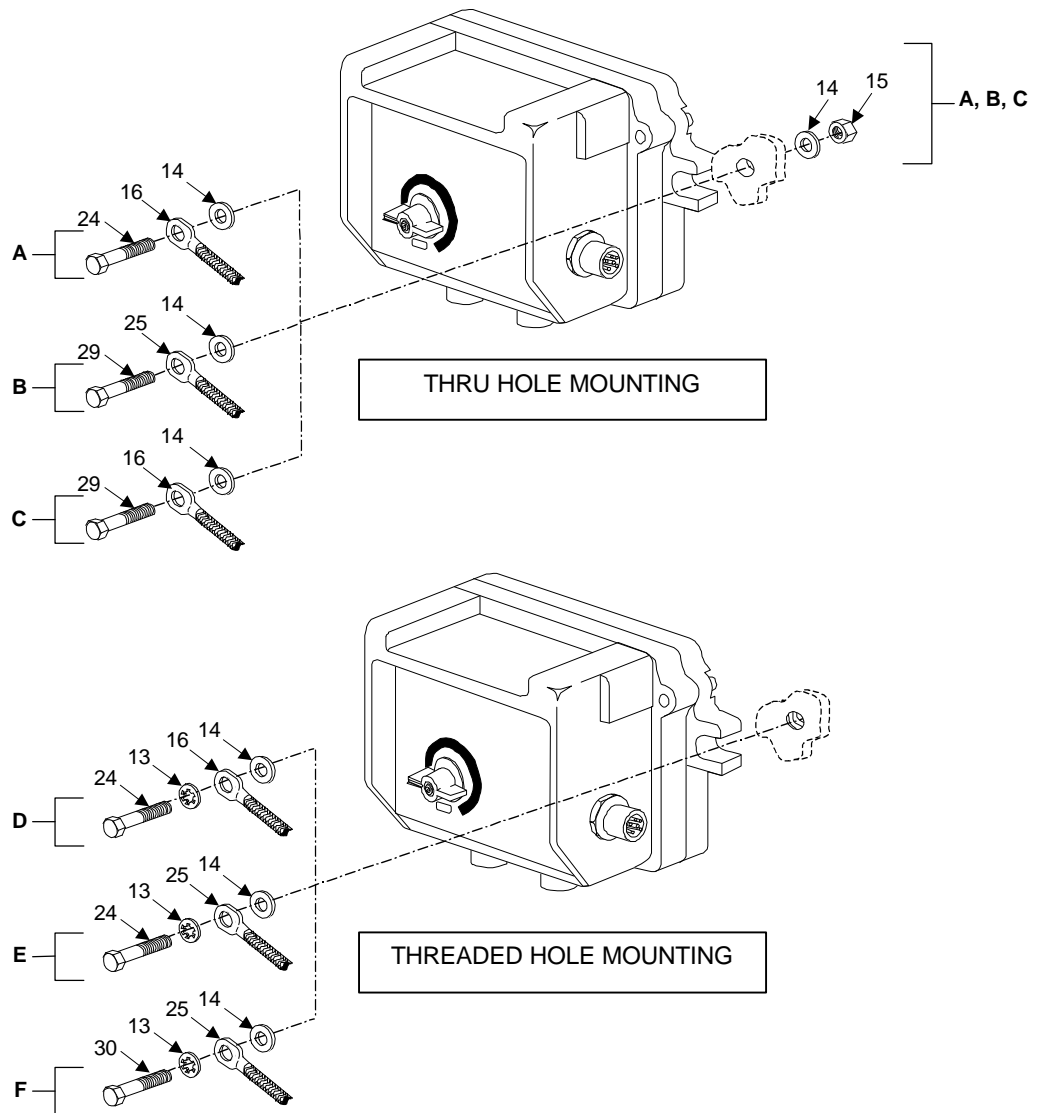

MOS Mounting Hardware

VEHICLE (AN/VIC-3(V))	POSITION FFCS MOUNTED IN	SEQ
M2A2 BRADLEY ((V)3)	BASKET SOLDIER	A
	CURBSIDE SOLDIER	D
	ROADSIDE SOLDIER	E
M2A2 ODS BRADLEY ((V)9)	ROADSIDE RIFLEMAN (FRONT), CURBSIDE GRENADIER	B
	ROADSIDE RIFLEMAN (CENTER)	F
	BASKET GRENADIER	C

Figure 1. Intercommunication Set, Vehicular AN/VIC-3(V) (Sheet 11 of 11)

SECTION II			TM 11-5830-263-20&P			
(1)	(2)	(3)	(4)	(5)	(6)	(7)
ITEM NO	SMR CODE	NSN	CAGEC	PART NUMBER	DESCRIPTION AND USABLE ON CODES(UOC)	QTY
GROUP 00 INTERCOMMUNICATION						
SET, VEHICULAR AN/VIC-3(V)1,						
(V)2, (V)3, (V)4, (V)5,						
(V)6, (V)7, (V)8, (V)9,						
(V)10, (V)11, (V)12, (V)13,						
(V)14, (V)15, (V)16, (V)17,						
(V)18						
FIGURE 1						
1	PAODD	5895013823221	80058	CD-82/VRC	CONTROL, INDICATOR -SEE FIGURE C-2 FOR PARTS	1
2	PAODD	5830013823218	80058	C-12357/VRC	CONTROL, INTERCOMMUN -SEE FIGURE C- 3 FDR PARTS	4
2	PAODD	5830013823218	80058	C-12357/VRC	UOC:KDO,KDR,LVB,LVC CONTROL, INTERCOMMUN -SEE FIGURE C- 3 FOR PARTS	6
2	PAODD	5830013823218	80058	C-12357/VRC	UOC:KDS,KDV,LHL CDNTROL, NTERCOMMUN -SEE FIGURE C- 3 FDR PARTS	5
2	PAODD	5830013823218	80058	C-12357/VRC	UOC:KDT,KDU,KDW,KDX,LHM,LVA CONTROL, INTERCOMMUN -SEE FIGURE C- 3 FDR PARTS	2
2	PAODD	5830013823218	80058	C-12357/VRC	UOC:LUY,LVE CONTROL, INTERCOMMUN -SEE FIGURE C- 3 FOR PARTS	3
3	PAODD	5895013823220	80058	C-12359/VRC	UOC:LUZ,LVD,23C INTERFACE UNIT, COMM	1
3	PAODD	5895013823220	80058	C-12359/VRC	UOC:KDU,LVA,23C INTERFACE UNIT, COMM	2
4	PAODD	5830013823209	80058	C-12358/VRC	UOC:KDW,KDX CONTROL, INTERCOMMUN -SEE FIGURE C- 4 FDR PARTS	3
4	PAODD	5830013823209	80058	C-12358/VRC	UOC:KDS CONTROL, INTERCOMMUN -SEE FIGURE C- 4 FOR PARTS	4
5	PAOOO	5965013823222	80058	LS-688/VRC	UDC: LHL LOUDSPEAKER, PERMANE -SEE FIGURE C- 5 FOR PARTS	1
6	PAOOO	5965013977542	80058	H-374(V)1/VRC	UOC:KDO,KDR,KDS,KDT,KDU,KDV,KDW,KDX, LHL,LHM,LUY,LUZ,LVA,LVB,LVD,23C HEADSET-MICROPHONE -SEE FIGURE C-6 FDR PARTS	1
6	PAOOO	5965013981551	80058	H-374(V)2/VRC	UOC:KDO,KDR,KDS,KDT,KDU,KDV,KDW,LHM HEADSET-MICROPHONE -SEE FIGURE C-6 FOR PARTS	2
6	PAOOO	5965013981551	80058	H-374(V)2/VRC	UOC:KDO,KDR,KDS,KDT,KDU,KDV,KDW,LHM HEADSET-MICROPHONE -SEE FIGURE C-6 FOR PARTS	1
6	PAOOO	5965013977544	80058	H-374(V)3/VRC	UOC:KDS,LHL HEADSET-MICROPHONE -SEE FIGURE C-6	1

SECTION II

TM 11-5830-263-20&P

(1) ITEM NO	(2) SMR CODE	(3) NSN	(4) CAGEC	(5) PART NUMBER	(6) DESCRIPTION AND USABLE ON CODES(UOC)	(7) QTY
					FOR PARTS	
6	PA000	5965013977544	80058	H-374(V)3/VRC	UOC:KDO,KDR,KDS,KDV,KDW,LHL HEADSET-MICROPHONE -SEE FIGURE C-6 FOR PARTS	2
7	PA000	5965013884181	80058	H-370/VRC	UOC:KDT,KDU,LHM HEADSET-MICROPHONE -SEE FIGURE C- 10 FOR PARTS.....	3
8	PA000	5955013857811	80058	H-365/VRC	UOC:KDX HEADSET,ELECTRICAL-SEE FIGURE C- 12 FOR PART5 BREAKDOWN.....	3
8	PA000	5965013857811	80058	H-365/VRC	UOC:KDS HEADSET,ELECTRICAL -SEE FIG. C-12 FOR PARTS.....	4
9	PA000	5965013857813	80058	H-366/VRC	UOC:LHL HEADSET-MICROPHONE -SEE FIGURE C- 13 FOR PARTS	3
10	PA000	5965013869134	80058	H-364/VRC	UOC:KDS,LHL HEADSET-MICROPHONE -SEE FIGURE C- 15 FOR PARTS.....	1
10A	PA000	5965014532687	80058	H-374(V)4/VRC	UOC:KDW,KDX HEADSET-MICROPHONE -SEE FIG. C-6 FOR PARTS	1
10A	PA000	5955014532884	80058	H-374(V)5/VRC	UOC:LUZ,LVA,LVB,LVC,LVD,23C HEADSET-MICROPHONE -SEE FIG. C-6 FOR PARTS.....	2
10A	PA000	5965014532684	80058	H-374(V)5/VRC	UOC:LUY,LUZ,LVB,LVD,LVE,23C HEADSET-MICROPHONE -SEE FIG. C-6 FOR PARTS.....	3
11A	PAOZZ	5995013927359	80063	A3206019-6	UOC:LVA,LVC CABLE ASSEMBLY,SPEC.....	2
11 A	PAOZZ	5995013927359	80063	A3206019-6	UOC:KDS,KDT,KDU,LHL,LHM,LUY CABLE ASSEMBLY,SPEC.....	1
11A	PAOZZ	5995013927359	80063	A3206019-6	UOC:KDV CABLE ASSEMBLY,SPEC.....	4
11 A	PAOZZ	5995013927359	80063	A3206019-6	UOC:KDW,KDX CABLE ASSEMBLY,SPEC.....	3
11A	PAOZZ	5995013927364	80063	A3206019-9	UOC:LVA CABLE ASSEMBLY,SPEC.....	2
11 A	PAOZZ	5995013927365	80063	A3206019-12	UOC:KDO,KDR CABLE ASSEMBLY,SPEC.....	1
11A	PAOZZ	5995014524310	80063	A3206019-2	UOC:KDU CABLE ASSEMBLY,SPEC.....	1
11 A	PAOZZ	5995014554213	80063	A3206019-4	UOC:LUZ,23C CABLE ASSEMBLY,RADI.....	1
11A	PAOZZ	5995014554213	80063	A3206019-4	UDC:LVB CABLE ASSEMBLY,RADI.....	2
11A	PAOZZ	5995014585334	80063	A3206019-3	UOC:23C CABLE ASSEMBLY,SPEC.....	2
1 1 A	PAOZZ	5995014588461	80063	A3206019-10	UOC:LVC,LVD CABLE ASSEMBLY,SPEC.....	2
					UOC:LVE	

SECTION II			TM 11-5830-263-20&P				(7)
(1)	(2)	(3)	(4)	(5)	(6)		
ITEM NO	SMR CODE	NSN	CAGEC	PART NUMBER	DESCRIPTION AND USABLE ON CODES(UOC)		QTY
11A	PAOZZ	5995013927326	80063	A3206127-6	CABLE ASSEMBLY,SPEC.,		1
					UOC:KDU,LVA		
11A	PAOZZ	5995013927326	80063	A3206127-6	CABLE ASSEMBLY,SPEC..		2
					UOC:KDW,KDX		
11A	PAOZZ	5995013929106	80063	A3206017-5	CABLE ASSEMBLY,POWE.,		1
					UOC:KDU,KDV,LUY,23C		
11A	PAOZZ	5995013929107	80063	A3206017-6	CABLE ASSEMBLY,POWE.....		1
					UOC:KDS,KDT,KDX,LHL,LHM,LVA		
11A	PAOZZ	5995013927323	80063	A3206017-7	CABLE ASSEMBLY,POWE.....		1
					UOC:KDU,KDR		
11A	PAOZZ	5995014061173	80063	A3206017-12	CABLE ASSEMBLY,POWE		1
					UOC:KDW		
11A	PAOZZ	5995014524309	80063	A3206017-3	CABLE ASSEMBLY,SPEC.		1
					UOC:LUZ,LVC,LVD		
11A	PAOZZ	5995014554211	80063	A3206017-4	CABLE ASSEMBLY,POWE		1
					UOC: LVB		
11A	PAOZZ	5985014588464	80663	A3206017-10	CABLE ASSEMBLY,SPEC		1
					UOC : LVE		
11B	PAOZZ	5995013926196	80063	A3206018-2	CABLE ASSEMBLY,SPEC		2
					UOC : KDU		
11B	PAOZZ	5996013926196	80063	A3206018-2	CABLE ASSEMBLY. SPEC		1
					UOC:KDW,KDX,LHL,LUY,LVC,LVE,23C		
11B	PAOZZ	5905014071230	80063	A3206018-3	CABLE ASSEMBLY,SPEC.....		1
					UOC : KDV , LHL		
11B	PAOZZ	5995013926199	80063	A3206018-5	CABLE ASSEMBLY,SPEC.....		1
					UOC:KDT,LVB		
11B	PAOZZ	5995013926199	80063	A3206018-5	CABLE ASSEMBLY,SPEC.....		2
					UOC:KDW		
11B	PAOZZ	5995013926202	80063	A3206018-4	CABLE ASSEMBLY,SPEC.....		1
					UOC:KDS,KDT,KDV,KDX,LHL,LHM,LUZ,LVA, 23C		
11B	PAOZZ	5995013926202	80063	A3206018-4	CABLE ASSEMBLY,SPEC.....		3
					UOC : LVD		
11B	PAOZZ	5995013926197	80063	A3206018-6	CABLE ASSEMBLY,SPEC.....		1
					UOC:KDS,KDU,KDV,LHL,LHM,LVA,LVD		
11B	PAOZZ	5995013926198	80063	A3206018-7	CABLE ASSEMBLY,SPEC.....		2
					UOC : LHL		
11B	PAOZZ	5995013926198	80063	A3206018-7	CABLE ASSEMBLY,SPEC.....		4
					UOC:KDS		
11B	PAOZZ	5995013926198	80063	A3206018-7	CABLE ASSEMBLY,SPEC.....		1
					UOC:KDT,KDU,LHM,LVA,23C		
11B	PAOZZ	5995013926203	80063	A3206018-8	CABLE ASSEMBLY,SPEC.....		1
					UOC:KDU,KDR,KDS,23C		
11B	PAOZZ	5995013926203	80063	A3206018-8	CABLE ASSEMBLY,SPEC..		2
					UOC : LHL		
11B	PAOZZ	5906014061172	80063	A3206018-9	CABLE ASSEMBLY,SPEC...		2
					UOC:KDX		
11B	PAOZZ	5995014061172	80063	A3206018-9	CABLE ASSEMBLY,SPEC...		3
					UOC : LVB		
11B	PAOZZ	5995013926204	80063	A3206018-12	CABLE ASSEMBLY,SPEC...		1
					UOC:KDU		
11B	PAOZZ	5995013926204	80063	A3206018-12	CABLE ASSEMBLY,SPEC..		2

SECTION II			TM 11-5830-263-20&P			
(1)	(2)	(3)	(4)	(5)	(6)	(7)
ITEM NO	SMR CODE	NSN	CAGEC	PART NUMBER	DESCRIPTION AND USABLE ON CODES(UOC)	QTY
11B	PAOZZ	5995014061171	80063	A3206018-10	UOC : KDX CABLE ASSEMBLY,SPEC.	1
11B	PAOZZ	5995013926200	80063	A3206018-15	UOC:KDW,LHL,LUZ,LVA CABLE ASSEMBLY , SPEC	1
11B	PAOZZ	5995013927356	80063	A3206018-19	UOC:KDS CABLE ASSEMBLY,SPEC.	1
11B	PAOZZ	5995013926201	80063	A3206018-16	UOC:KDU,KDW CABLE ASSEMBLY, SPEC	1
11B	PAOZZ	5995013926201	80063	A3206018-16	UOC:KDU,KDW,LVB,23C CABLE ASSEMBLY,SPEC.....	2
11B	PAOZZ	5995013929114	80063	A3206018-20	UOC : LVE CABLE ASSEMBLY,SPEC.... . . .	1
11B	PAOZZ	5995013927352	80063	A3206018-21	UOC:KDQ,KDR,KDV CABLE ASSEMBLY,SPEC.... . . .	1
11B	PAOZZ	5995014635659	80063	A3206018-11	UOC:KDO,KDR,KDT,LHM,LVA CABLE ASSEMBLY,SPEC	2
11B	PAOZZ	5995014524307	80063	A3206018-18	uoc : LUY CABLE ASSEMBLY,SPEC.	1
11B	PAOZZ	5995014524308	80063	A3206018-24	uoc : LUZ CABLE ASSEMBLY , SPEC	1
11B	PAOZZ	5995014586014	80063	A3206018-13	uoc : LUZ CABLE ASSEMBLY,SPEC.	1
11B	PAOZZ	5995014593791	80063	A3206018-17	uoc : LVC CABLE ASSEMBLY, SPEC. -	1
11C	PAOZZ	5995013927358	80063	A3206023-13-16	uoc : LVC CABLE ASSEMBLY SPEC.....	1
11C	PAOZZ	5995013927319	80063	A3206081-3-3	UOC:KDS,KDT,LHL,LHM,LVA CABLE ASSEMBLY,SPEC.....	1
11C	PAOZZ	5995013927320	80063	A3206102-4-4	UOC:KDO CABLE ASSEMBLY,SPEC.....	1
11C	PAOZZ	5995013927321	80063	A3206120-3-3	UOC:KDO CABLE ASSEMBLY,SPEC.....	1
11C	PAOZZ	5995013927322	80063	A3206121-4-5	UOC : KDR CABLE ASSEMBLY,SPEC.....	1
11D	PAOZZ	5995014061183	80063	A3206308-30	UOC : KDR CABLE ASSEMBLY,SPEC.....	1
11E	PAOZZ	5995013927362	80063	A3206021-1	UOC : KDY CABLE ASSEMBLY,SPEC.....	1
11E	PAOZZ	5995013927363	80063	A3206021-19	UOC:KDV CABLE ASSEMBLY,SPEC.....	1
11F	PAOZZ	5995013869116	80063	A3206118	UOC : KDQ CABLE ASSEMBLY,SPEC.....	1
11G	PAOZZ	5995013869109	80063	A3206020	UOC:KDR CABLE ASSEMBLY,SPEC.....	4
11G	PAOZZ	5995013869109	80063	A3206020	UOC:KDQ,KDR,KDX,LVA,LVC CABLE ASSEMBLY,SPEC	9
11G	PAOZZ	5995013869109	80063	A3206020	UOC : KDS CABLE ASSEMBLY,SPEC.	5
11G	PAOZZ	5995013869109	80063	A3206020	UOC:KDT,KDU,KDW,LHM CABLE ASSEMBLY, SPEC	2
11G	PAOZZ	5995013869109	80063	A3206020	UOC:KDV,LUZ CABLE ASSEMBLY,SPEC.....	1.0

SECTION II			TM 11-5830-263-20&P				
(1)	(2)	(3)	(4)	(5)	(6)	(7)	
ITEM	SMR			PART			
NO	CODE	NSN	CAGEC	NUMBER	DESCRIPTION AND USABLE ON	CODES(UOC)	QTY
					uoc : LHL		
11G	PAOZZ	5995013869109	80063	A3206020	CABLE ASSEMBLY,SPEC.....		3
					UOC:LVB,LVD		
11G	PAOZZ	5995014295177	80063	A3206444	CABLE ASSEMBLY,SPEC.....		2
					UOC:KDV,LUY,LVE		
11G	PAOZZ	5995014295177	80063	A3206444	CABLE ASSEMBLY,SPEC.....		1
					uoc : LUZ		
11G	PAOZZ	5995014295177	80063	A3206444	CABLE ASSEMBLY,SPEC.....		3
					UOC : 23C		
11H	PAOZZ	5995013927325	80063	A3206116	CABLE ASSEMBLY,SPEC.....		1
					UOC:KDS,KDT,LHL,LHM,LVA		
11I	PAOZZ	5995013937694	80063	A3206193-6	CABLE ASSEMBLY,SPEC.....		1
					UOC:KDO,KDR,KDS,KDT,KDU,KDV,KDW,KDX, LHL,LHM,LUY,LUZ,LVA,LVB,23C		
11I	PAOZZ	5995013930216	80063	A3206193-30	CABLE ASSEMBLY,SPEC.....		1
					UOC:KDO,KDR,KDU,KDW,KDX,LHL,LHM,LUY, LVB , LVD		
11J	PAOZZ	5995014061181	80063	A3206309-2	CABLE ASSEMBLY,SPEC.....		1
					UOC:KDW		
11K	PAOZZ	5995014061174	80063	A3206249-3	CABLE ASSEMBLY,SPEC.....		1
					UOC:KDX		
11K	PAOZZ	5995014061175	80063	A3206249-16	CABLE ASSEMBLY,SPEC.....		1
					UOC : KDX		
11L	PAOZZ	5995014224683	80063	A3206129-2	CABLE ASSEMBLY,SPEC.....		1
					UOC : KDV		
11L	PAOZZ	5995014061179	80063	A3206307-6	CABLE ASSEMBLY,SPEC.....		1
					UOC:KDW		
11L	PAOZZ	5995014081178	80063	A3206307-30	CABLE ASSEMBLY,SPEC.....		1
					UOC:KDW		
11M	PAOZZ	5995014061177	80063	A3206317-25	CABLE ASSEMBLY,SPEC.....		1
					UOC : KDV		
11N	PAOZZ	5995014061176	80063	A3206130-10	CABLE ASSEMBLY,SPEC.....		1
					UOC : KDV		
11O	PAOZZ	5995014071231	80063	A3206257-16-21	CABLE ASSEMBLY,SPEC.....		1
					UOC:KDS,LHL		
11O	PAOZZ	5995014071233	80063	A3206257-16-25	CABLE ASSEMBLY,SPEC.....		1
					UOC : KDT		
11O	PAOZZ	5995014261354	80063	A3206257-16-17	CABLE ASSEMBLY,SPEC.....		1
					UOC:LHM,LVA		
11O	PAOZZ	5995014635657	80063	A3207048-13-13	CABLE ASSEMBLY,SPEC.....		1
					uoc : LVC		
11O	PAOZZ	5995014635658	80063	A3207048-13-15	CABLE ASSEMBLY,SPEC.....		1
					uoc : LVC		
11P	PAOZZ	5935014439068	80063	A3206465	DUMMY CONNECTOR,PLU.....		1
					UOC:KDX		
11Q	PAOZZ	5995014331229	80063	A3206461-5-12	CABLE ASSEMBLY,SPEC.....		1
					UOC :KDX		
11R	PAOZZ	5995014331228	80063	A3206463	CABLE ASSEMBLY,SPEC.....		1
					UOC:KDX		
11S	PAOZZ	5995014620374	80063	A3206618	CABLE ASSEMBLY,SPEC.....		1
					UOC : LVD		
11T	PAOZZ	5995014568955	80063	A3207043	CABLE ASSEMBLY,SPEC.....		1

SECTION II		TM 11-5830-263-20&P			(6)	(7)	
(1)	(2)	(3)	(5)				
ITEM	SMR		PART				
NO	CODE	NSN	CAGEC	NUMBER	DESCRIPTION AND USABLE ON	CODES(UOC)	QTY
					UOC:LUY,LVE		
11U	PAOZZ	5995014635655	80063	A3207046	CABLE ASSEMBLY,SPEC...		1
					UOC : LYE		
12	PAOZZ	5310008807746	96906	MS51968-5	NUT,PLAIN,HEXAGON.....		10
					UOC:KDO,KDR,23C		
12	PAOZZ	5310008807746	96906	MS51968-5	NUT,PLAIN,HEXAGON.....		16
					UOC : KDU		
12	PAOZZ	5310008807746	96906	MS51968-5	NUT,PLAIN,HEXAGON.....		8
					UOC:KDW		
12	PAOZZ	5310008807746	96906	MS51968-5	NUT,PLAIN,HEXAGON.....		4
					UOC : KDX		
12	PAOZZ	5310008807746	96906	MS51968-5	NUT,PLAIN,HEXAGON.....		2
					UDC : LVE		
13	PAOZZ	5310001670721	96906	MS35333-41	WASHER,LOCK.....		10
					UOC:KDO,KDR		
13	PAOZZ	5310001670721	96906	MS35333-41	WASHER,LOCK.....		4
					UOC:KDS		
13	PAOZZ	5310001670721	96906	MS35333-41	WASHER,LDCK.....		16
					UOC:KDU,KDW		
13	PAOZZ	5310001670721	96906	MS35333-41	WASHER,LOCK.....		12
					UOC:KDV,LHL		
13	PAOZZ	5310001670721	96906	MS35333-41	WASHER,LOCK.....		20
					uoc : LVC		
14	PAOZZ	5310000814219	96906	MS27183-12	WASHER,FLAT.....		10
					UOC:KDO,KDR		
14	PAOZZ	5310000814219	96906	MS27183-12	WASHER,FLAT.....		46
					UOC:KDS		
14	PAOZZ	5310000814219	96906	MS27183-12	WASHER,FLAT.....		30
					UOC:KDT,LHM		
14	PAOZZ	5310000814219	96906	MS27183-12	WASHER,FLAT.....		16
					UOC:KDU,KDW		
14	PAOZZ	5310000814219	96906	MS27183-12	WASHER,FLAT.....		12
					UOC : KDV		
14	PAOZZ	5310000814219	96906	MS27183-12	WASHER,FLAT.....		47
					UOC : LHL		
14	PAOZZ	5310000814219	96906	MS27183-12	WASHER,FLAT.....		4
					uoc : LUY		
14	PAOZZ	5310000814219	96906	MS27183-12	WASHER,FLAT.....		51
					UOC : LVA		
14	PAOZZ	5310000814219	96906	MS27183-12	WASHER,FLAT.....		20
					UOC:LVC,LVD		
14	PAOZZ	5310000814219	96906	MS27183-12	WASHER,FLAT.....		8
					UOC : LVE		
15	PAOZZ	5310009843806	96906	MS51922-9	NUT, SELF-LOCKING,HE.....		27
					UOC : KDS		
15	PAOZZ	5310009843806	96906	MS51922-9	NUT,SELF-LOCKING,HE.....		20
					UOC:KDT,LHM		
15	PAOZZ	5310009843806	96906	MS51922-9	NUT,SELF-LOCKING,HE.....		11
					UOC : LHL		
15	PAOZZ	5310009843806	81349	M45913/1-5CG5C	NUT,SELF-LOCKING,HE.....		39
					UOC : LVA		
15	PAOZZ	5310009843806	81349	M45913/1-5CG5C	NUT,SELF-LOCKING,HE.....		10

SECTION II			TM 11-5830-263-20&P			(7)
(1)	(2)	(3)	(4)	(5)	(6)	
ITEM NO	SMR CODE	N S N	CAGEC	PART NUMBER	DESCRIPTION AND USABLE ON CODES(UOC)	QTY
16	PAOZZ	5999014121339	80063	A3206132	UOC:LVC STRIP,ELECTRICAL GR.....	8
16	PAOZZ	5999014121339	80063	A3206132	UOC:KDS STRIP,ELECTRICAL GR.....	6
16	PAOZZ	5999014121339	80063	A3206132	UOC:KDT STRIP,ELECTRICAL GR.....	7
16	PAOZZ	5999014121339	80063	A3206132	UOC:LHL STRIP,ELECTRICAL GR.....	5
16	PAOZZ	5999014121339	80063	A3206132	UOC:LHM,LVA STRIP,ELECTRICAL CR.....	3
16	PAOZZ	5999014121339	80063	A3206132	UOC:LVC STRIP,ELECTRICAL GR.....	4
17	PAOZZ	5310008807744	96906	MS51967-5	UOC:LVD NUT,PLAIN,HEXAGON.....	4
18	PAOZZ	5999014121342	80063	A3206131	UOC:KDV STRIP,ELECTRICAL GR.....	1
19	PAOZZ	5305002259091	96906	MS90726-36	UOC:KDV SCREW,CAP,HEXAGON li.....	16
20	PAOZZ	5310008892527	96906	MS45904-72	UOC:KDU,KDW,KDX WASHER,LOCK.....	16
20	PAOZZ	5310008892527	96906	MS45904-72	UOC:KDU WASHER,LOCK.....	8
20	PAOZZ	5310008892527	96906	MS45904-72	UOC:KDW WASHER,LOCK.....	20
21	PAOZZ	5305002253843	80204	B1821BH025C100N	UOC:KDX,LUZ SCREW,CAP,HEXAGON H.....	2
21	PAOZZ	5305002253843	80204	B1821BH025C100N	UOC:KDQ,KDR SCREW,CAP,HEXAGON H.....	4
21	PAOZZ	5305002253843	80204	B1821BH025C100N	uoc:LUY SCREW,CAP,HEXAGON H.....	12
22	PAOZZ	5310005501130	96906	MS35333-40	UOC:LVB WASHER,LOCK.....	2
22	PAOZZ	5310005501130	96906	MS35333-40	UOC:KDQ,KDR WASHER,LOCK.....	4
23	PAOZZ	5310011036042	96906	MS51412-4	UOC:23C WASHER,FLAT.....	2
23	PAOZZ	5310011036042	96906	MS51412-4	UOC:KDQ,KDR WASHER,FLAT..	12
23	PAOZZ	5310011036042	96906	MS51412-4	UOC:LVB WASHER,FLAT..	4
24	PAOZZ	5306010758519	96906	MS90725-36	UOC:23C BOLT,MACHINE..	18
24	PAOZZ	5306610758519	96906	MS90725-36	UOC:KDS BOLT, MACHINE..	10
24	PAOZZ	5306010758519	96906	MS90725-36	UOC:KDT,LUZ,LVD BOLT,MACHINE.....	8
24	PAOZZ	5306010758519	96906	MS90725-36	UOC:KDV,LVC BOLT,MACHINE.....	6
25	PAOZZ	5999014121341	80063	A3206133	UOC:LVE STRIP,ELECTRICAL GR.....	2
25	PAOZZ	5999014121341	80063	A3206133	UOC:KDS STRIP,ELECTRICAL GR.....	4

SECTION II			TM 11-5830-263-20&P			
(1)	(2)	(3)	(4)	(5)	(6)	(7)
ITEM NO	SMR CODE	NSN	CAGEC	PART NUMBER	DESCRIPTION AND USABLE ON CODES(UOC)	QTY
25	PAOZZ	5999014121341	80063	A3206133	UOC:KDV,LHL STRIP,ELECTRICAL G R	1
26	PAOZZ	5305000680516	96906	M590726-9	UOC:LHM,LVA SCREW,CAP,HEX.....	4
27	PAOZZ	5310008892528	96906	MS45904-68	UOC : KDV WASHER,LOCK.....	8
27	PAOZZ	5310008892528	96906	MS45904-68	UOC:KDS,KDV WASHER,LOCK.....	12
28	PAOZZ	5310008094058	96906	MS27183-10	UOC: LVB WASHER,FLAT.....	4
29	PAOZZ	5306002264830	80204	B1821BH031C138N	UOC: KDV, LUY BOLT,MACHINE.....	17
29	PAOZZ	5306002264830	80204	B1821BH031C138N	UOC: LHL SCREW,CAP,HEXAGON H	10
29	PAOZZ	5306002264830	80204	B1821BH031C138N	UOC: LHM BOLT,MACHINE.....	12
30	PAOZZ	5306002258499	80058	MS90725-34	UOC: LVA BOLT,HEX,HEAD.....	6
30	PAOZZ	5306002258499	80058	MS90725-34	UOC: LHL BOLT, HEX, HEAD...	4
30	PAOZZ	5306002258499	80058	MS90725-34	UOC: LUY BOLT, HEX, HEAD	2
31	PAOZZ	5310007680319	96906	MS51968-2	UOC: LVC NUT, PLAIN, HEXAGON	2
32	PAOZZ	5310004079566	96906	MS35338-45	UOC: 23C WASHER,LOCK.....	4
33	PAOZZ	5310005825965	96906	MS5338-44	UOC: LUY WASHER,LOCK.....	4
34	PAOZZ	5310008299981	96906	MS35649-2312	UOC: LUY NUT, PLAIN, HEXAGON	1 0
35	PAOZZ	5310007282044	96906	MS45904-73	UOC: LUZ WASHER,LOCK.....	7
36	PAOZZ	5310007616882	96906	MS51967-2	UOC: LVA NUT, PLAIN, HEXAGON.....	12
37	PAOZZ	5999014590532	80063	A3207044	UOC: LVB STRIP,ELECTRICAL O R	2
38	PAOZZ	5310005146674	96906	MS35335-34	UOC: LVC WASHER,LOCK.....	20
39	PAOZZ	5310009318167	96906	MS51967-6	UOC: LVD NUT,PLAIN,HEXAGON.....	10
40	PAOZZ	5310005967693	96906	MS35335-31	UOC: LVD WASHER,LOCK.....	8
41	PAOZZ	5305002259093	96906	MS90726-38	UOC: LVE SCREW,CAP,HEXAGON H	10
42	PAOZZ	5310006163056	96906	MS35335-41	UOC: 23C WASHER, LOCK	20
43	PAOZZ		81349	M83413/8-AO21CD	UOC: 23C LEAD, ELECTRICAL	1
44	PAOZZ	5310000446477	96906	MS51412-25	UOC : 23C WASHER, FLAT	20
45	PAOZZ	5305002678954	96906	MS90726-10	UOC: 23C SCREW, CAP, HEX, HE	2
					UOC : 23C	

END OF FIGURE

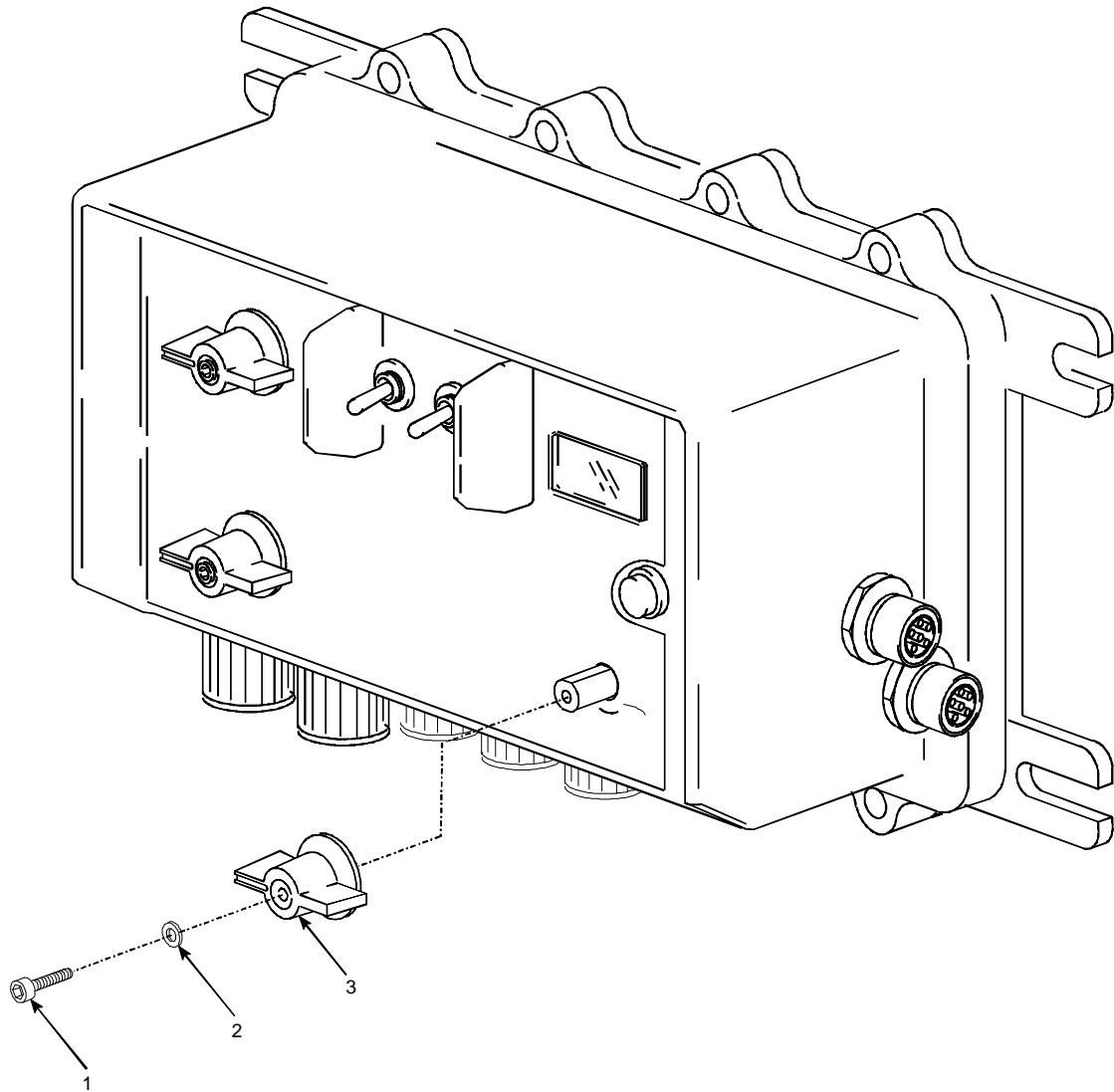

Figure 2. Control, Indicator CD-82/VRC

SECTION II			TM11-5830-263-20&P		(6)	(7)
(1)	(2)	(3)	(4)	(5)		
ITEM	SMR			PART		
NO	CODE	NSN	CAGEC	NUMBER	DESCRIPTION AND USABLE ON CODES(UOC)	QTY
					GROUP 01 CONTROL INDICATOR	
					CD-82/VRC	

FIGURE 2

1	PAQZZ	5305014573848	80063	A3205937	SCREW,CAP, SOCKET HE.....	3
2	PAQZZ	5310014551831	80063	A3205978	WASHER SPRING TENS.....	3
3	PAQZZ	5355006169659	96906	MS91525-0-A-P-3- A-0-Z	KNOB.....	3

END OF FIGURE

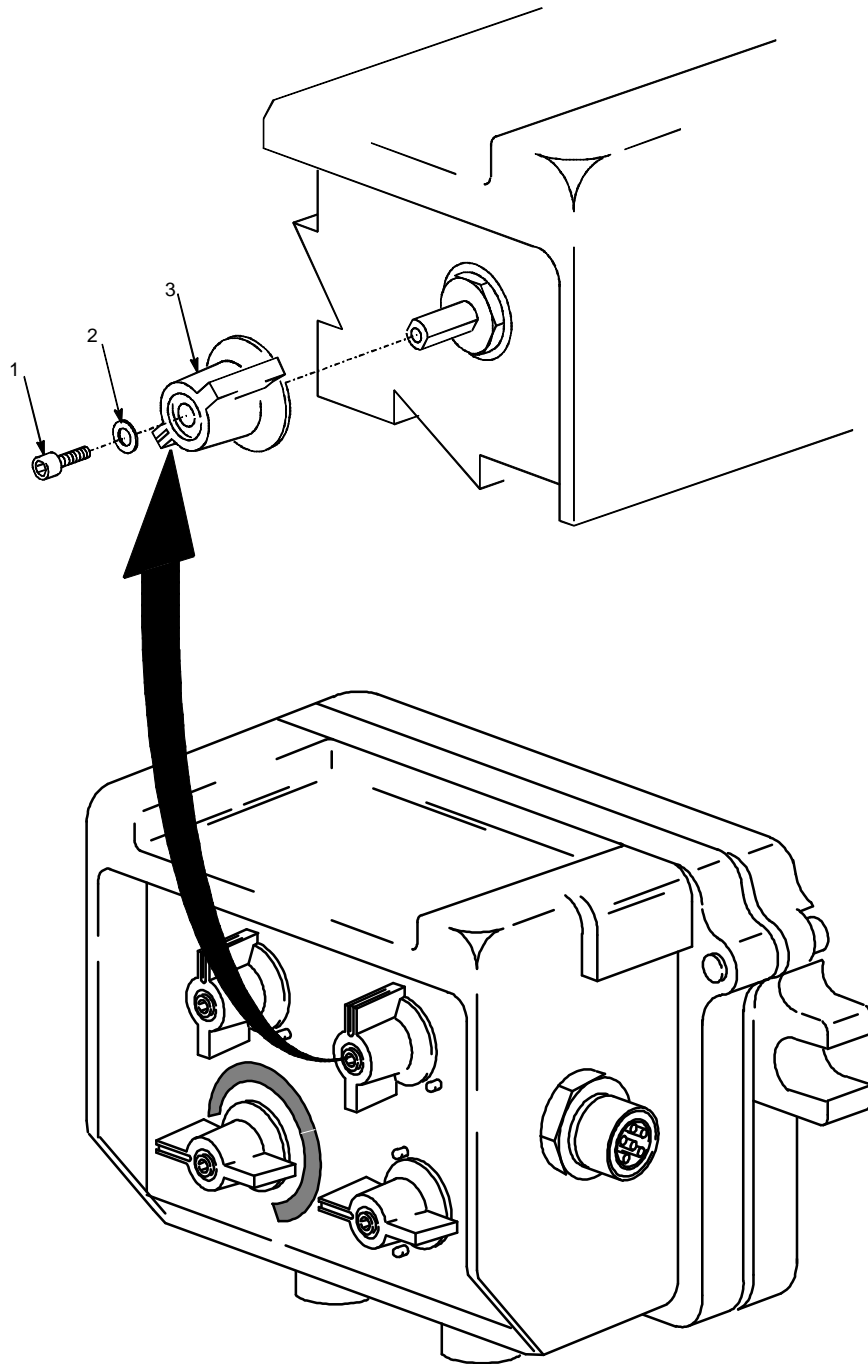

Figure 3. Control, Intercommunication Set C-12357/VRC

SECTION II
 (1) (2) (3)
 ITEM SMR
 NO CODE NSN

TM11-5830-263-20&P
 (4) (5)
 CAGEC PART
 NUMBER

(6) (7)

DESCRIPTION AND USABLE ON CODES(UOC) QTY
 GROUP O2 CONTROL, INTERCOMMUNICATION
 SET C-12357/VRC

FIGURE 3

1	PAOZZ	5305014573848	80063	A3205937	SCREW, CAP, SOCKET HE.....	4
2	PAOZZ	5310014551831	80063	A3205978	WASHER SPRING TENSI.....	4
3	PAOZZ	5355006169659	96906	MS91525-0-A-P-3-S-0-Z	KNOB.....	4

END OF FIGURE

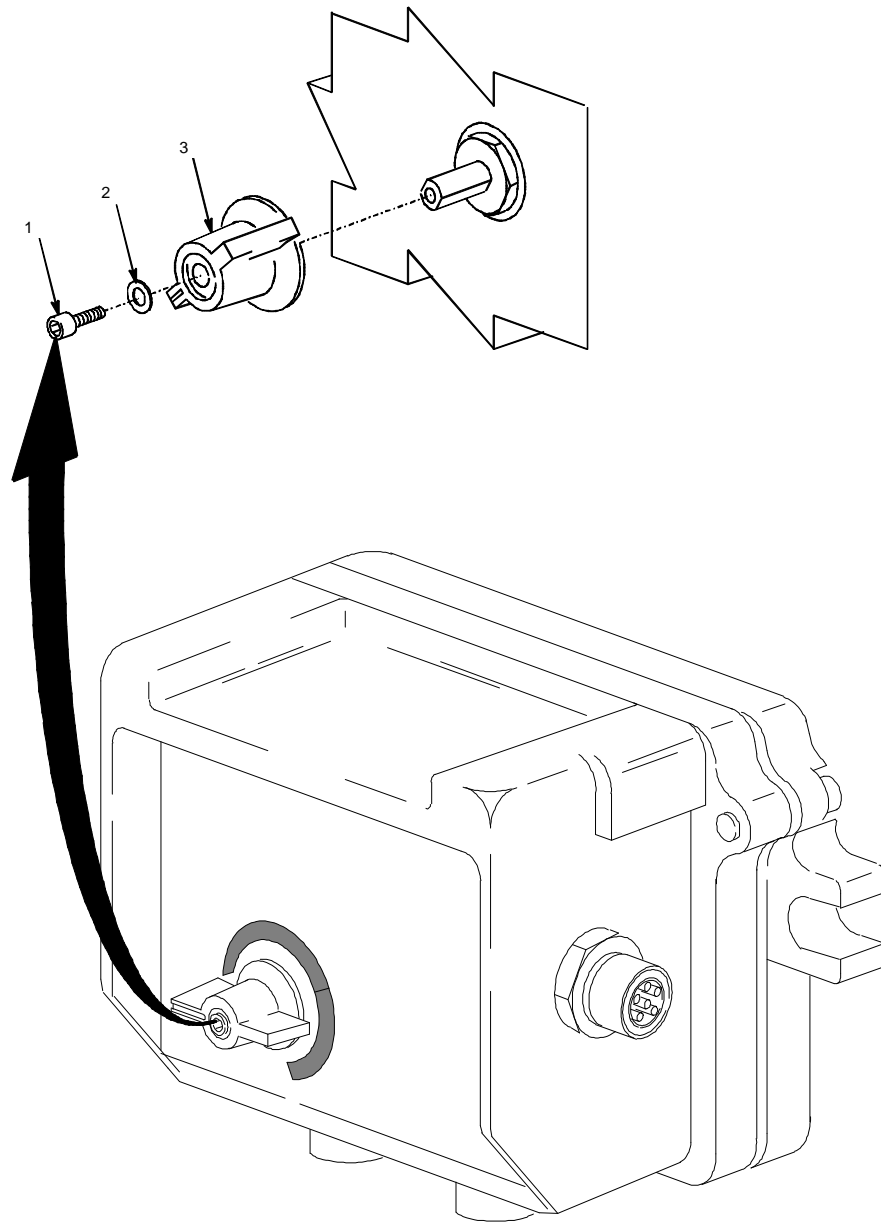

Figure 4. Control, Intercommunication C-12358/VRC

SECTION II			TM11-5830-263-20&P			
(1)	(2)	(3)	(4)	(5)	(6)	(7)
ITEM	SMR			PART		
NO	CODE	NSN	CAGEC	NUMBER	DESCRIPTION AND USABLE ON CODES(UOC)	QTY

**GROUP 04 CONTROL, INTERCOMMUNICAT-
ION SET C-12358/VRC**

FIGURE 4

1 PAQZZ	5305014573848	80063	A3205937	SCREW,CAP, SOCKET HE	1
2 PAQZZ	5310014551831	80063	A3205978	WASHER SPRING TENSI	1
3 PAQZZ	5355006169659	96906	MS91525-0-A-P-3- S-0-Z	KNOB	1

END OF FIGURE

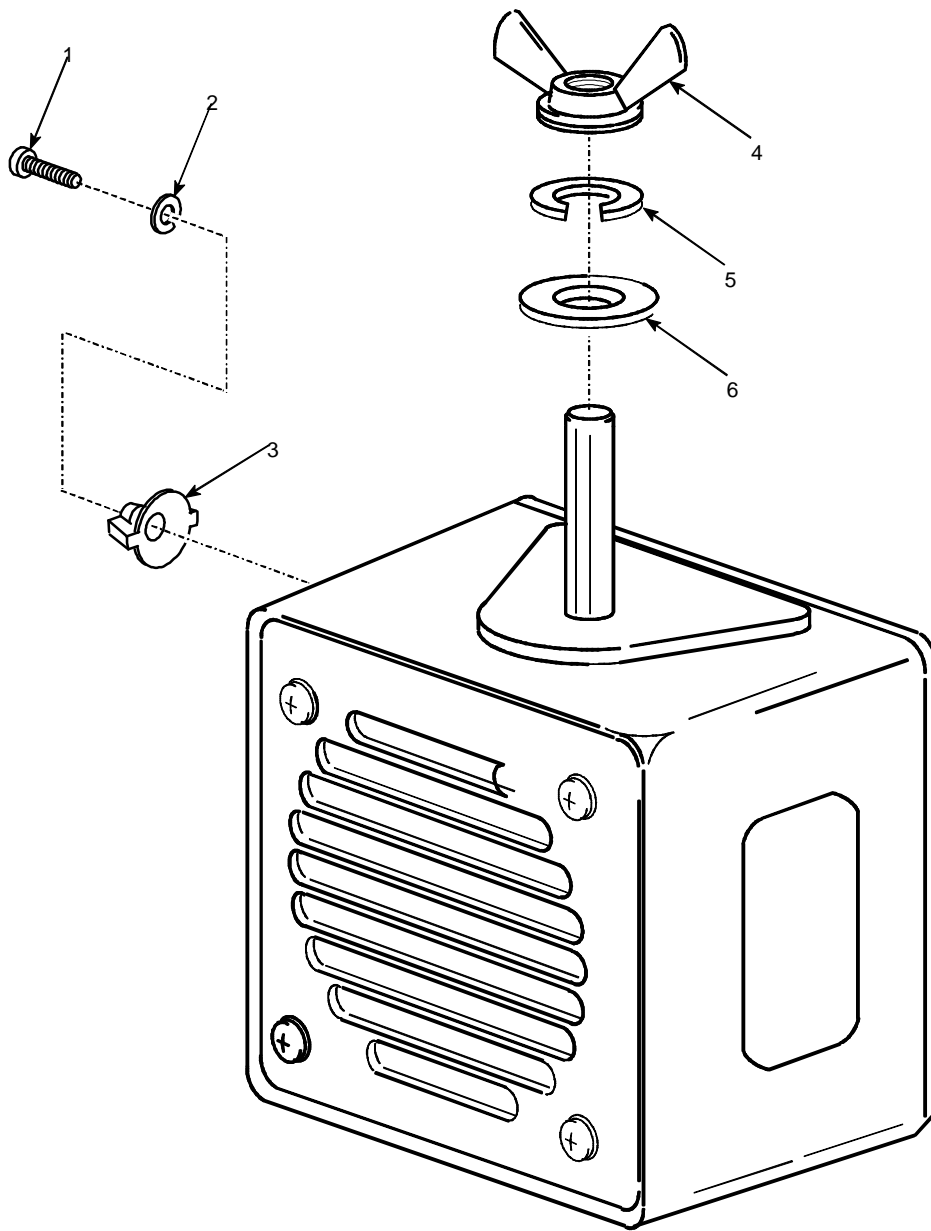

Figure 5. Loudspeaker, Permanent Magnet LS-688/VRC

(1) ITEM NO	SECTION II		TM 11-5830-263-20&P		(6) DESCRIPTION AND USABLE ON CODES (UOC)	(7) QTY
	(2) SMR CODE	(3) N S N	(4) CAGEC	(5) PART NUMBER		

GROUP 05 LOUDSPEAKER, PERMANENT
LS-888/VRC

FIGURE 5

1	PAOZZ	5305008893000	96906	MS35206-230	SCREW, MACHINE	1
					UOC: KDO, KDR, KDS, KDT, KDU, KDV, KDW, KDX, LHL, LHM, LUY, LUZ, LVA, LVB, LVD, 23C	
2	PAOZZ	5310000454007	96906	MS35338-41	WASHER, LOCK	1
					UOC: KDO, KDR, KDS, KDT, KDU, KDV, KDW, KDX, LHL, LHM, LUY, LUZ, LVA, LVB, LVD, 23C	
3	PAOZZ	5355014519354	96906	MS91524-9AW2SOX	KNOB	1
					UOC: KDO, KDR, KDS, KDT, KDU, KDV, KDW, KDX, LHL, LHM, LUY, LUZ, LVA, LVB, LVD, 23C	
4	PAOZZ	5310010802211	96906	MS35426-31	NUT, PLAIN, WING	1
					UOC: KDO, KDR, KDS, KDT, KDU, KDV, KDW, KDX, LHL, LHM, LUY, LUZ, LVA, LVB, LVD, 23C	
5	PAOZZ	5310006379541	96906	MS35338-46	WASHER, LOCK	1
					UOC: KDO, KDR, KDS, KDT, KDU, KDV, KDW, KDX, LHL, LHM, LUY, LUZ, LVA, LVB, LVD, 23C	
6	PAOZZ	5310000806004	96906	MS27183-14	WASHER, FLAT	1
					UOC: KDO, KDR, KDS, KDT, KDU, KDV, KDW, KDX, LHL, LHM, LUY, LUZ, LVA, LVB, LVD, 23C	

END OF FIGURE

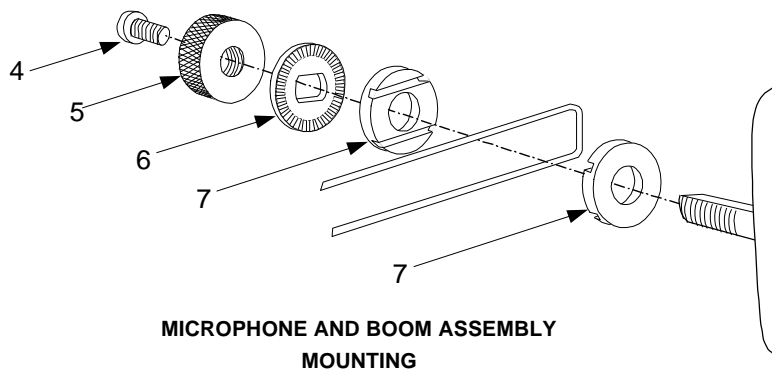
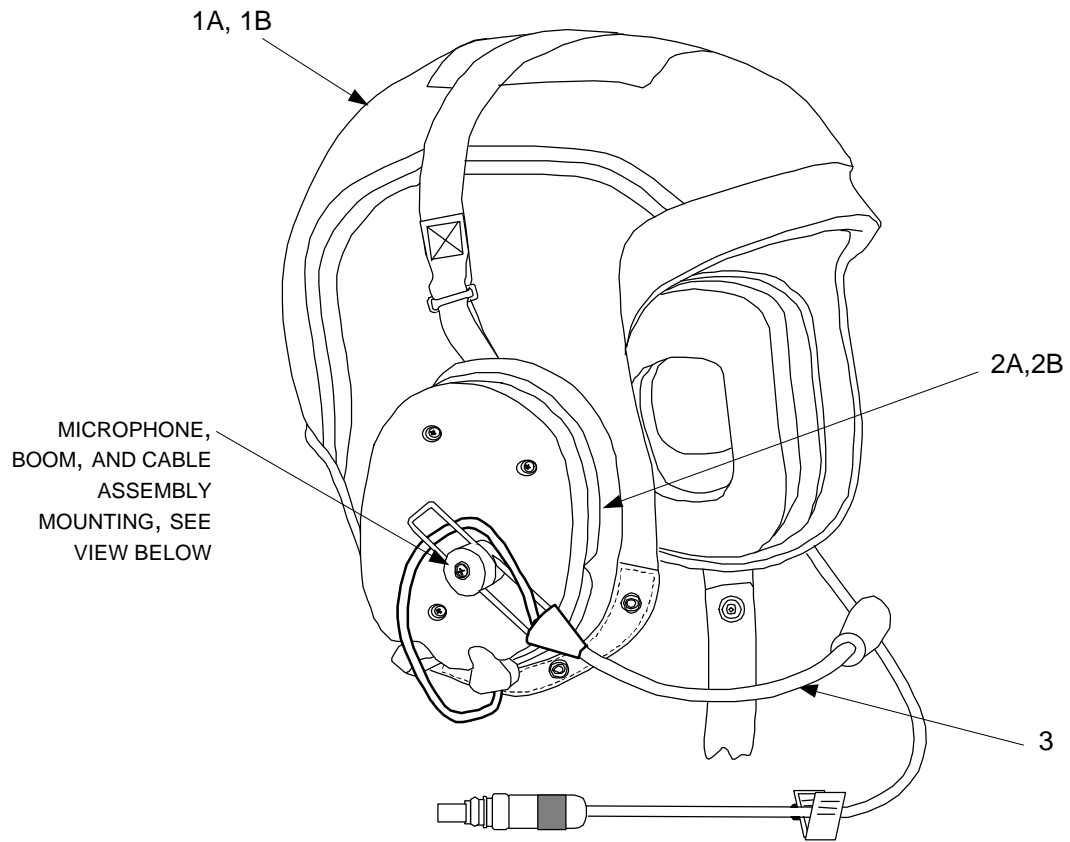
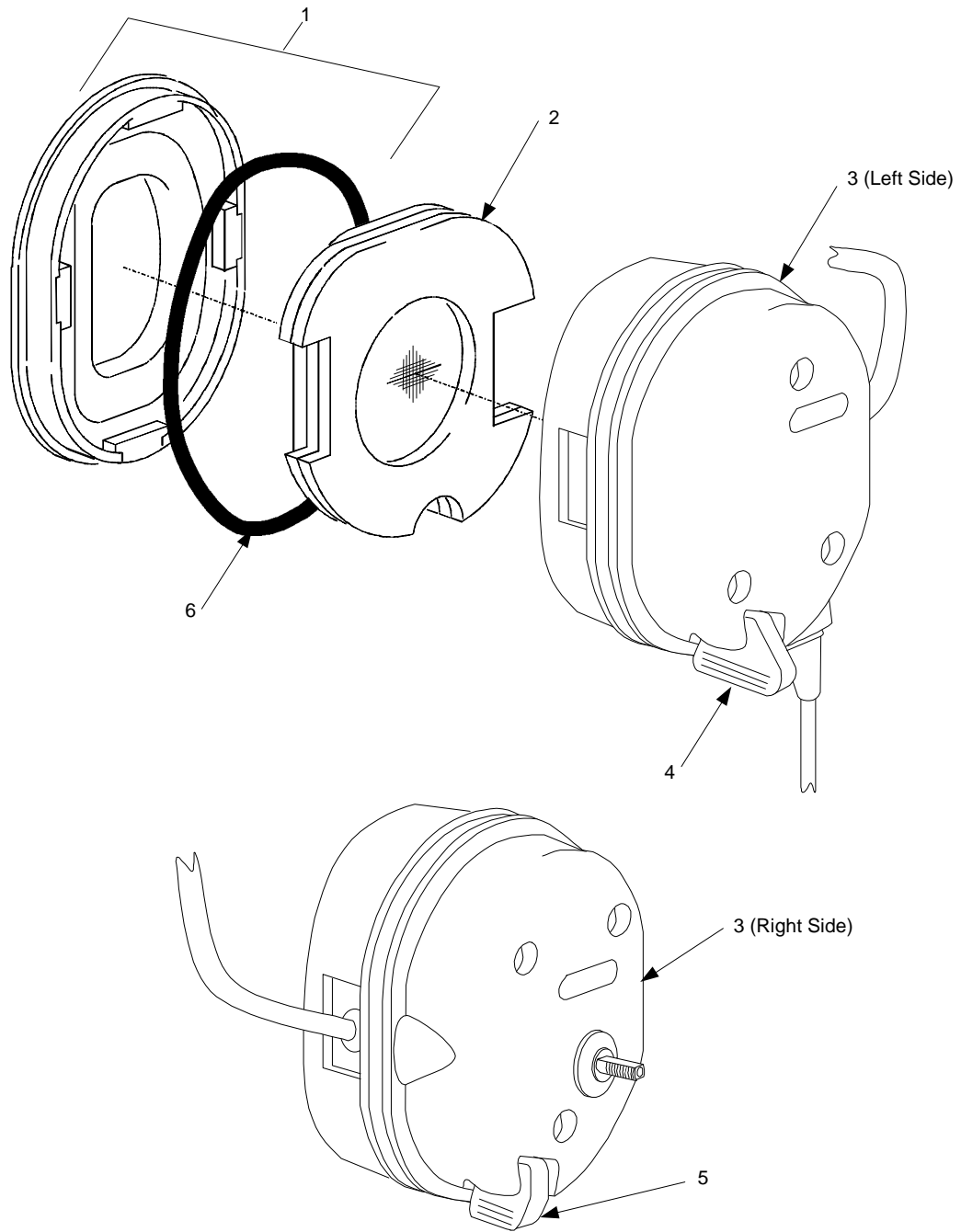

Figure 6. Headset, Microphone H-374(V)1, (V)2, (V)3, (V)4 and (V)5/VRC

SECTION II			TMI1-5830-263-20&P			
(1)	(2)	(3)	(4)	(5)	(6)	(7)
ITEM NO	SMR CODE	NSN	CAGEC	PART NUMBER	DESCRIPTION AND USABLE ON CODES(UOC)	QTY
					GROUP 06 HEADSET- MICROPHONE H-374(V) 1/VRC, H374(V) 2/VRC H-374(V) 3/VRC, H374(V) 4/VRC H-374(V) 5/VRC	
					FIGURE 6	
1A	PA00Z		80063	A3206617-2	LINER, COMBAT VEHICL -A3206617-2 IS SIZE MEDIUM. REQUISITION THIS ITEM WHEN REPLACING THE OLD CVC LINERS A3206143-1(SMALL) AND A3206143-2 (MEDIUM). SEE FIG. C-9 FOR PARTS. UOC: KDQ, KDR, KDS, KDT, KDU, KDV, KDW, LHL, LHM, LUZ, LVA, LVB, LVC, LVD, 23C	1
1B	PA00Z		80063	A3206617-3	LINER, COMBAT VEHICL -A3206617-3 IS SIZE LARGE. THIS LINER REPLACES THE OLD CVC LINER A3206143-3(LARGE). SEE FIG. C-9 FOR PARTS. UOC: KDQ, KDR, KDS, KDT, KDU, KDV, KDW, LHL, LHM, LUY, LUZ, LVA, LVB, LVC, LVD, LVE, 23C	1
2A	PA0DD	5965014198196	80063	A3206414	HEADSET, ELECTRICAL -SEE FIG. C-7 (SHEET 1) FOR PARTS. WHEN RETURNING THIS COMPONENT (A3206414) TO DEPOT FOR REPAIR ENSURE THE LINER, MICROPHONE, BOOM, AND CABLE ASSEMBLY; AND BOOM MOUNTING HARDWARE ARE RETAINED FOR REUSE. DISCARD THE EARCUSHIONS AND FRONT FOAM ASSEMBLY(S). THE REPLACEMENT EARCUPS AND CABLE ASSEMBLY WILL CONTAIN NEW EARCUSHIONS AND FRONT FOAM ASSEMBLY(S) UOC: KDQ, KDR, KDS, KDT, KDU, KDV, KDW, LHL, LHM	1
2B	PA0DD	5965014640220	80063	A3206613	HEADSET, ELECTRICAL -SEE FIG. C-7 (SHEET 2) FOR PARTS. WHEN RETURNING THIS COMPONENT (A3206613) TO DEPOT FOR REPAIR ENSURE THE LINER, MICROPHONE, BOOM, AND CABLE ASSEMBLY; AND BOOM MOUNTING HARDWARE ARE RETAINED FOR REUSE. REMOVE BATTERY FROM BATTERY COMPARTMENT. DISCARD THE EARCUSHIONS AND FRONT FOAM ASSEMBLY(S). THE REPLACEMENT EARCUPS AND CABLE ASSEMBLY WILL CONTAIN NEW EARCUSHIONS AND FRONT FOAM ASSEMBLY(S) UOC: LUY, LUZ, LVA, LVB, LVC, LVD, LVE, 23C	1
3	PA00Z	5965014624079	80063	A3206616	BOOM, MICROPHONE -SEE FIG. C-8 FOR PARTS. UOC: KDQ, KDR, KDS, KDT, KDU, KDV, KDW, LHL, LHM, LUY, LUZ, LVA, LVB, LVC, LVD, LVE, 23C	1
4	PA0ZZ	5305004890742	96906	MS51957-41B	SCREW, MACHINE. UOC: KDQ, KDR, KDS, KDT, KDU, KDV, KDW, LHL, LHM, LUY, LUZ, LVA, LVB, LVC, LVD, LVE, 23C	1
5	PA0ZZ	5310014439064	80063	A3206457	NUT, PLAIN, KNURLED. UOC: KDQ, KDR, KDS, KDT, KDU, KDV, KDW, LHL, LHM, LUY, LUZ, LVA, LVB, LVC, LVD, LVE, 23C	1
6	PA0ZZ	5310014439063	80063	A3206456	WASHER, SHOULDERED A. UOC: KDQ, KDR, KDS, KDT, KDU, KDV, KDW, LHL, LHM, LUY, LUZ, LVA, LVB, LVC, LVD, LVE, 23C	1
7	PA0ZZ	5310014446389	80063	A3206455	WASHER, SLOTTED. UOC: KDQ, KDR, KDS, KDT, KDU, KDV, KDW, LHL, LHM, LUY, LUZ, LVA, LVB, LVC, LVD, LVE, 23C	2

END OF FIGURE

C-6-1/(C-6-2 blank)



A3206414

Figure 7. Headset, Electrical Assembly (Sheet 1 of 2)

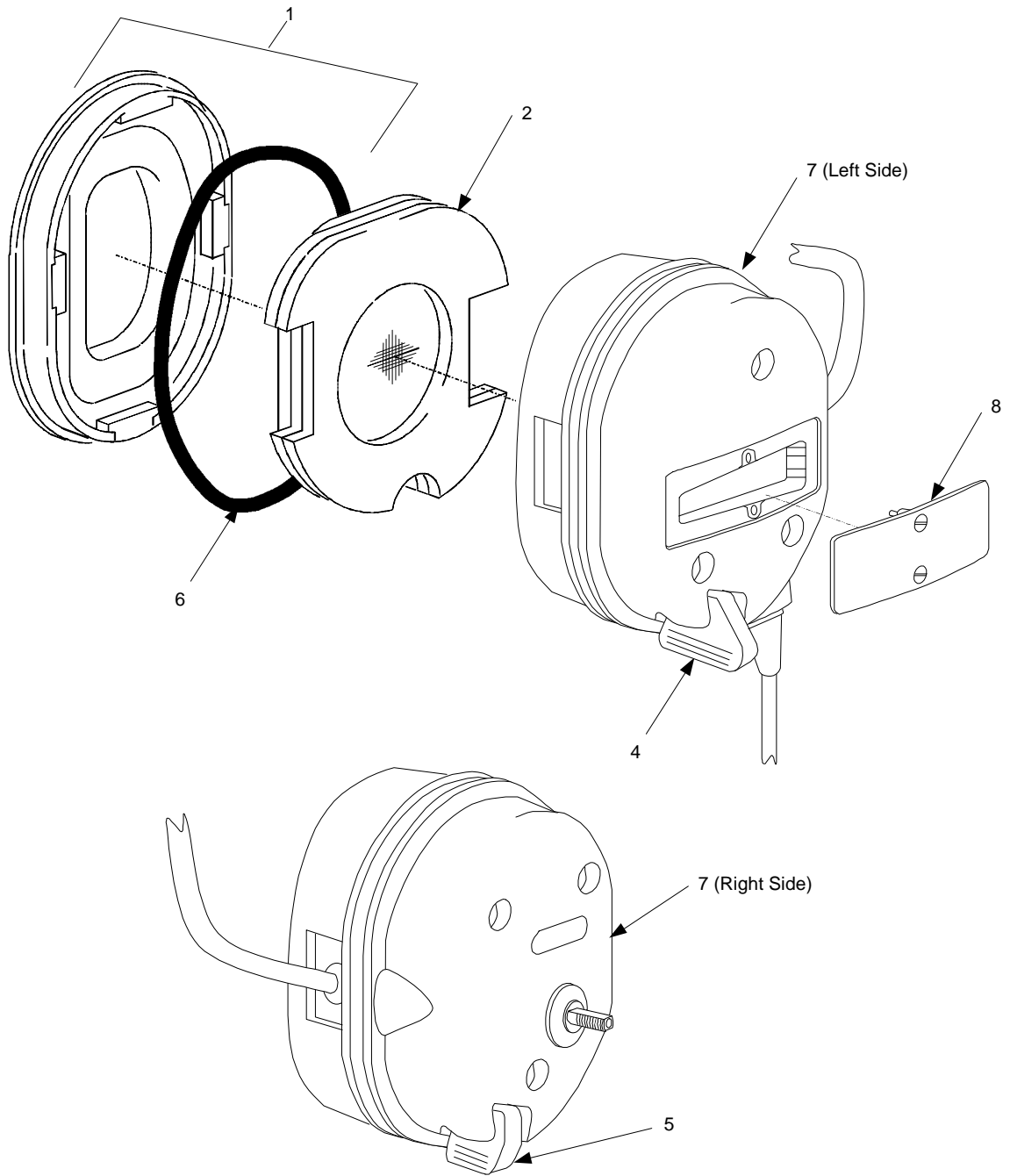

A3206613

Figure 7. Headset, Electrical Assembly (Sheet 2 of 2)

SECTION II			TM 11-5830-263-20&P			
(1)	(2)	(3)	(4)	(5)	(6)	(7)
ITEM NO	SMR CODE	NSN	CAGEC	PART	DESCRIPTION AND USABLE ONCODES(UOC)	QTY
GROUP 0601 HEADSET,ELECTRICAL ASSY A3206414, A3206613						
FIGURE 7						
1	PAOZZ	5965014185535	80063	A3206613-3	CUSHION,EAR	2
UOC:KDQ,KDR,KDS,KDT,KDU,KDV,KDW,LHL, LHM,LUY,LUZ,LVA,LVB,LVC,LVD,LVE,23C						
2	PAOZZ	5895014640223	80063	A3206613-2	COVER,ELECTRONIC CO	2
UOC:KDQ,KDR,KDS,KDT,KDU,KDV,KDW,LHL, LHM,LUY,LUZ,LVA,LVB,LVC,LVD,LVE,23C						
3	XAODD		80063	A3206414-1	EARCUPS & CABLE ASS -SEE FIG. 6. ITEM 2A (A3206414) FOR INSTRUCTIONS FOR DEPOT RETURN.....	1
UOC:KDQ,KDR,KDS,KDT,KDU,KDV,KDW,LHL, LHM						
4	PAOZZ	5930014649981	80063	A3206613-5	COVER,ELECTRICAL SW	1
UOC:KDQ,KDR,KDS,KDT,KDU,KDV,KDW,LHL, LHM,LUY,LUZ,LVA,LVB,LVC,LVD,LVE,23C,						
5	PAOZZ	5930014649985	80063	A3206613-6	COVER,ELECTRICAL SW	1
UOC:KDQ,KDR,KDS,KDT,KDU,KDV,KDW,LHL, LHM,LUY,LUZ,LVA,LVB,LVC,LVD,LVE,23C						
6	XAOZZ		32108	179544-2	O - R I N G	2
UOC:KDQ,KDR,KDS,KDT,KDU,KDV,KDW,LHL, LHM,LUY,LUZ,LVA,LVB,LVC,LVD,LVE,23C						
7	XAODD		80063	A3206613-1	EARCUPS & CABLE ASS -SEE FIG. 6 ITEM 2B (A3206613) FOR INSTRUCTIONS FOR DEPOT RETURN.....	1
UOC:LUY,LUZ,LVA,LVB,LVC,LVD,LVE,23C						
8	PAOZZ	6160014640221	80063	A3206613-4	COVER,BATTERY	2

END OF FIGURE

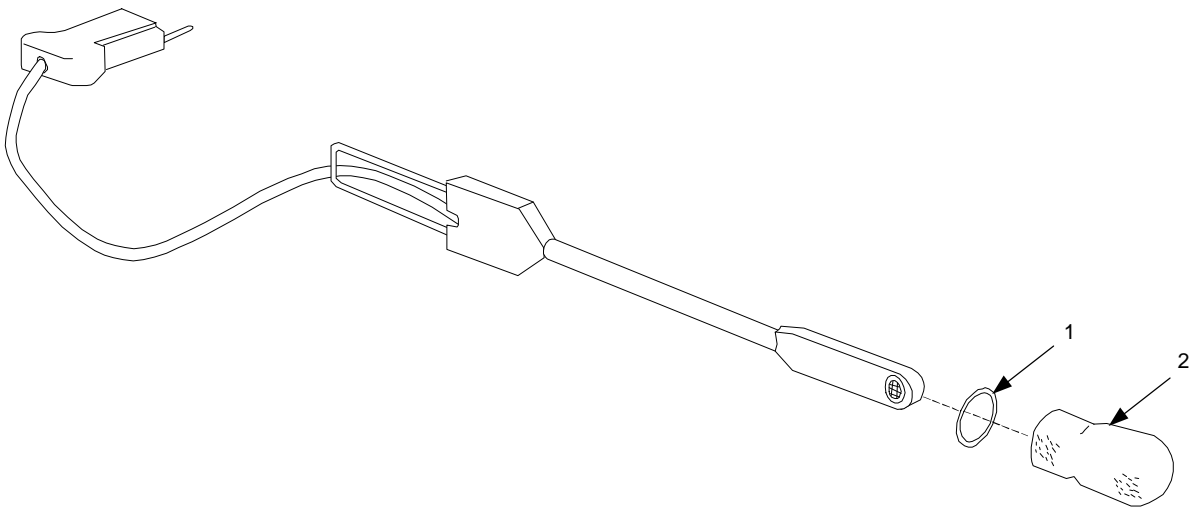
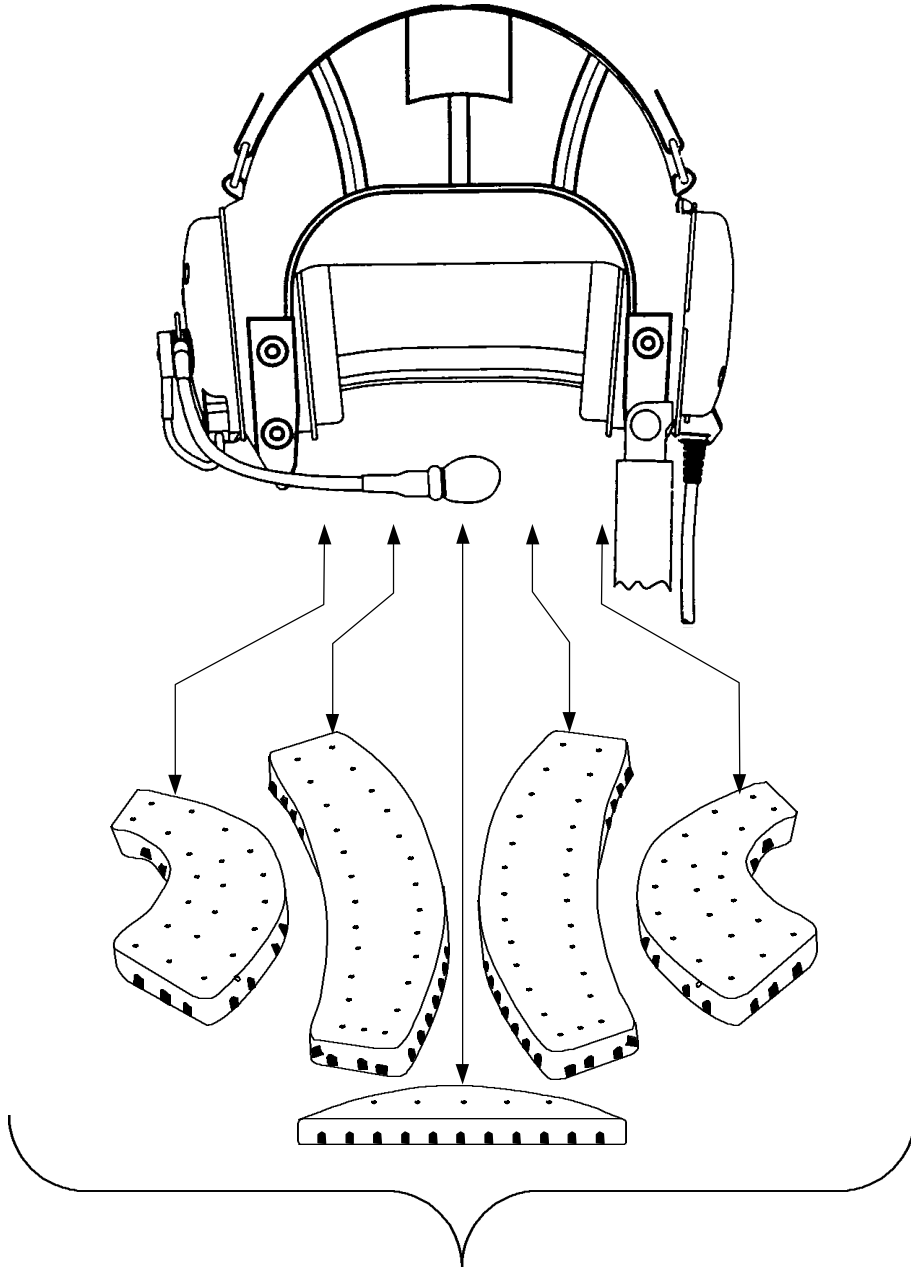

Figure 8. Microphone, Boom and Cable Assembly M-175/VRC

SECTION II			TM11-5830-263-20&P			
(1)	(2)	(3)	(4)	(5)	(6)	(7)
ITEM NO	SMR CODE	NSN	CAGEC	PART NUMBER	DESCRIPTION AND USABLE ON CODES(UOC)	QTY
					GROUP 0602 MICROPHONE, BOOM & CABLE ASSEMBLY M-175/VRC	
					FIGURE 8	
1	PAOZZ	5330002483836	96906	MS29513-012	O-RING	1
					UOC: KDQ, KDR, KDS, KDT, KDU, KDV, KDW, LHL, LHM, LUY, LUZ, LVA, LVB, LVC, LVD, LVE, 23C	
2	PAOZZ	5965014111856	26512	A3206345	SHIELD, MICROPHONE	1
					UOC: KDQ, KDR, KDS, KDT, KDU, KDV, KDW, LHL, LHM, LUY, LUZ, LVA, LVB, LVC, LVD, LVE, 23C	

END OF FIGURE



1A, 1B

Figure 9. Liner, CVC

SECTION II			TM11- 5830- 263- 20&P			
(1)	(2)	(3)	(4)	(5)	(6)	(7)
ITEM	SMR			PART		
NO	CODE	NSN	CAGEC	NUMBER	DESCRIPTION AND USABLE ON CODES(UOC)	QTY

GROUP 0603 LINER, CVC

FIGURE 9

1A PAOZZ		80063 A3206617- 22	PAD SET, FITTING COM -REQUISITION	1
			THIS ITEM WHEN REPLACING THE PADS IN	
			THE OLD CVC, SMALL(A3206143- 1) AND	
			MEDIUM (A3206143- 2) LINERS.	
			UOC: KDQ, KDR, KDS, KDT, KDU, KDV, KDW, LHL,	
			LHM, LUZ, LVA, LVB, LVC, LVD, 23C	
1B PAOZZ		80063 A3206617- 23	PAD SET, FITTING COM - THIS PAD SET	1
			CAN ALSO BE USED TO REPLACE THE PADS IN	
			THE OLD CVC LARGE (A3206142- 3) LINER. . .	
			UOC: KDQ, KDR, KDS, KDT, KDU, KDV, KDW, LHL,	
			LHM, LUY, LUZ, LVA, LVB, LVC, LVD, LVE, 23C	

END OF FIGURE

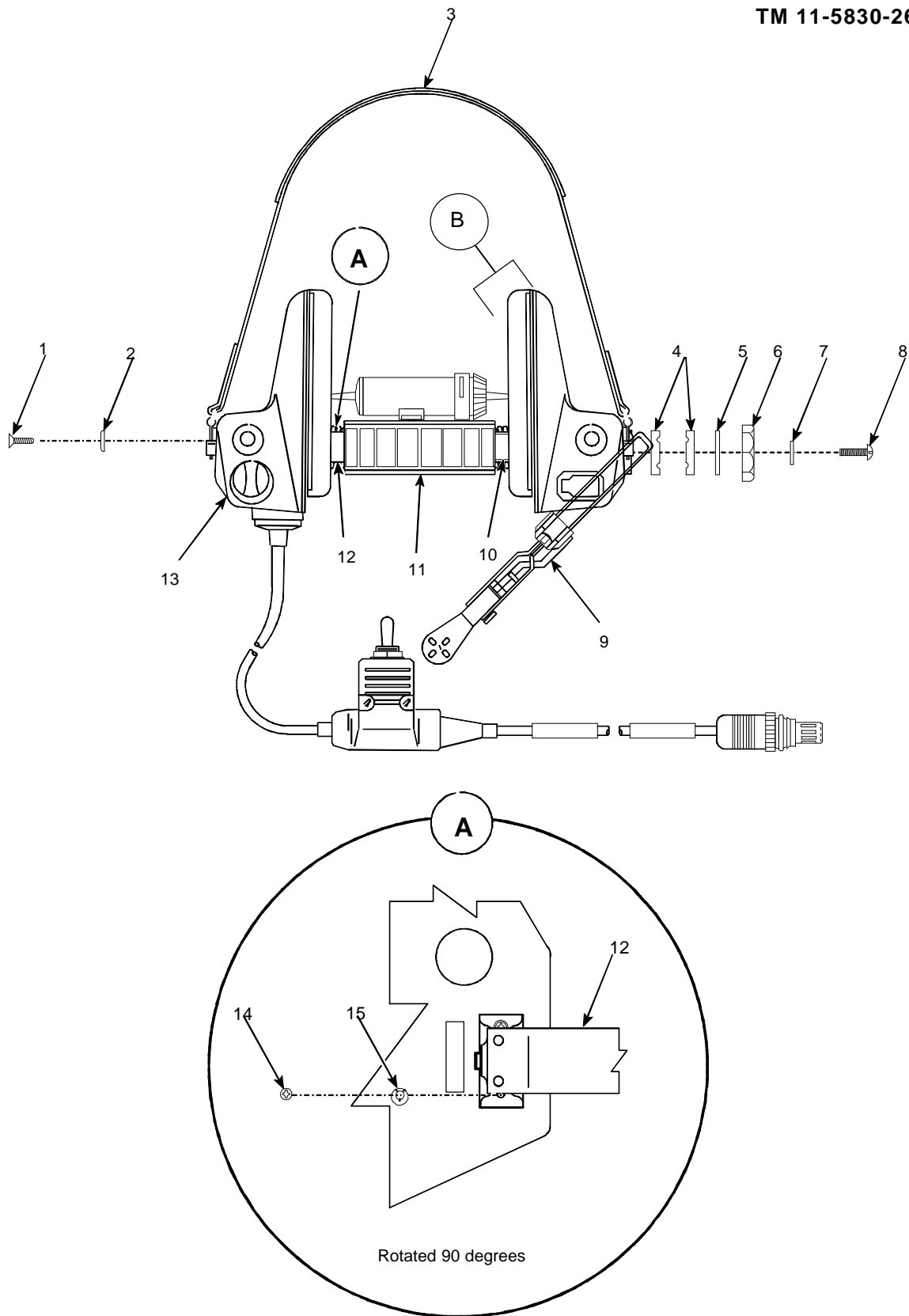

Figure 10. Headset, Microphone H-370/VRC (Sheet 1 of 2)

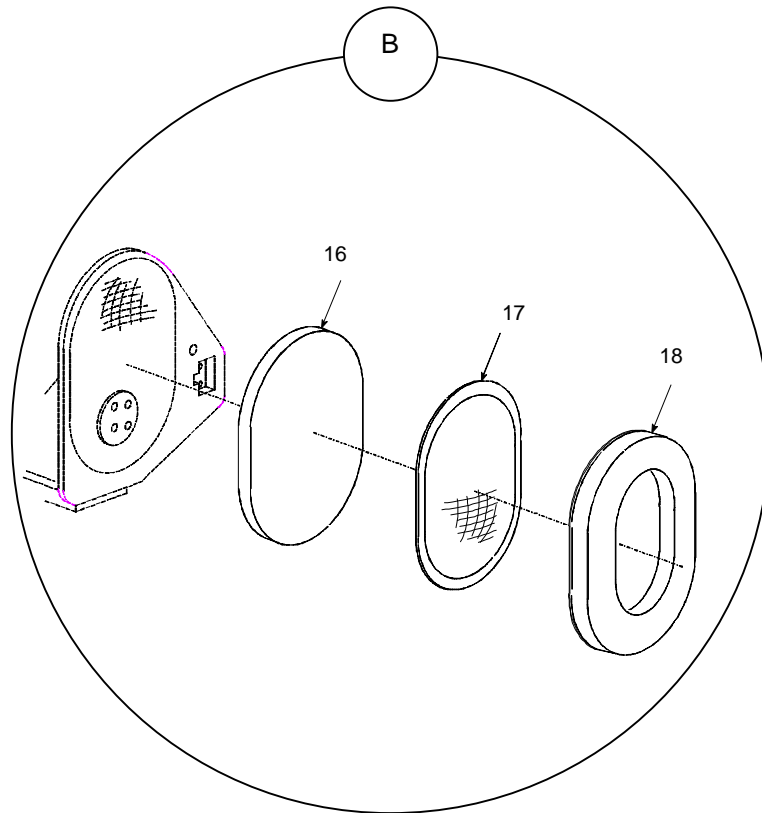

Figure 10. Headset, Microphone H-370/VRC (Sheet 2 of 2)

SECTION II
 (1) (2) (3) TM 11-5830-263-20&P (6) (7)
ITEM SMR (4) (5) DESCRIPTION AND USABLE ON CODES(UOC) QTY
 NO CODE NSN CAGEC PART NUMBER

GROUP 07 HEADSET-MICROPHONE
 H-370/VRC

FIG. 10

1	PAOZZ	5305014185490	80063	A3206418	SCREW,MACHINE.....	2
					UOC:KDS,KDX,LHL	
2	PAOZZ	5310014185489	80063	A3206417	WASHER,FLAT.....	2
					UOC:KDS,KDX,LHL	
3	PAOZZ		80063	A3206361	HEADBAND,HEADSET.....	1
					UOC:KDS,KDX,LHL	
4	PAOZZ	5310014493249	80063	A3206541	WASHER,SLOTTED.....	2
					UOC:KDS,KDX,LHL	
5	PAOZZ	5310014491099	80063	A3206540	WASHER,SHOULDERED.....	1
					UOC:KOS,KDX,LHL	
6	PAOZZ	5355014184375	80063	A3206424	KNOB.....	1
					UOC:KDS,KDX,LHL	
7	PAOZZ	5310014491096	80063	A3206539	WASHER BLANK	1
					UOC:KDS,KDX,LHL	
8	PAOZZ	5305014184378	80063	A3206423	SCREW,EXTERNALLY RE.....	1
					UOC:KDS,KDX,LHL	
9	PAOOO	5965014491092	80063	A3206367	MICROPHONE,DYNAMIC -SEE FIGURE C-	1
					11 FOR PARTS.....	
					UOC:KDX	
10	XBOZZ		80063	A3206387	LABEL,IDENT -SEE SB 11-631 FOR	1
					INSTRUCTIONS	
					UOC:KDX	
11	PAOZZ	8415014222243	80063	A3206347	PAD,HELMET NAPESTR.....	1
					UOC:KDS,KDX,LHL	
12	PAOZZ	5340014184377	80063	A3206348	HOLDER,SPRING	1
					UOC:KDS,KDX,LHL	
13	XAOZZ	5965014491093	80063	A3206368	HEADSET,ELECTRICAL	1
					UOC:KDX	
14	PAOZZ	5305014185488	80063	A3206419	SCREW,EXTERNALLY RE.....	4
					UOC:KDS,KDX,LHL	
15	PAOZZ	5310014491097	80063	A3206571	WASHER,CONCAVE	4
					UOC:KDS,KDX,LHL	
16	PAOZZ	8415014222250	80063	A3206430-4	PAD,CUSHIONING	2
					UOC:KDS,KDX,LHL	
17	PAOZZ		80063	A3206430-3	COVER,DIAPHRAGM	2
					UOC:KDS,KDX,LHL	
18	PAOZZ	5965014184373	80063	A3206430-2	CUSHION,EAR	2
					UOC:KDS,KDX,LHL	

END FIGURE

C-I0-I

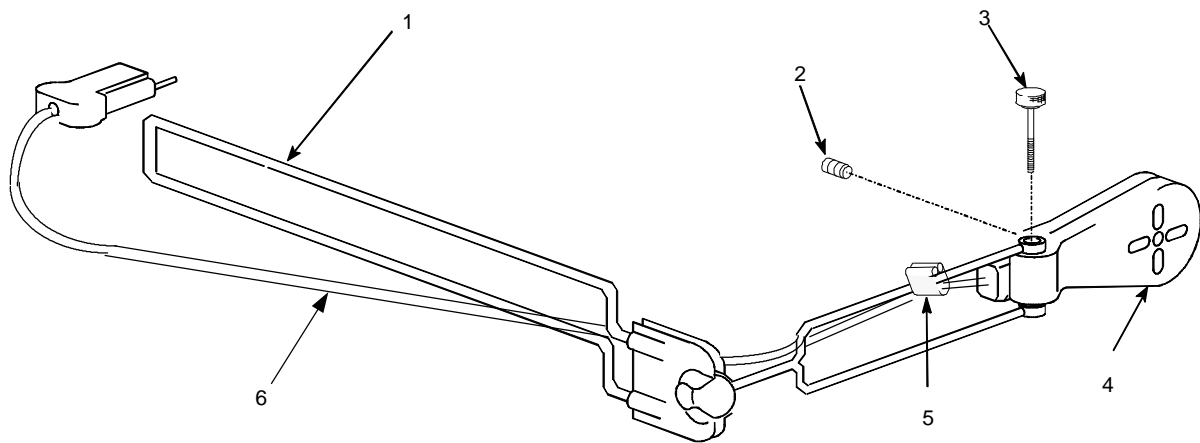

Figure 11. Microphone, Boom and Cable Assembly M-173/VRC

SECTION II			TM11- 5830- 263- 20&P			
(1)	(2)	(3)	(4)	(5)	(6)	(7)
ITEM	SMR			PART		
NO	CODE	NSN	CAGEC	NUMBER	DESCRIPTION AND USABLE ON CODES(UOC)	QTY

GROUP 0701 MICROPHONE, BOOM, AND
CABLE ASSEMBLY M- 173- VRC

FIGURE 11

1	PAOZZ	5965010497236	80063	A3206358	BOOM, MICROPHONE.	1
					UOC: KDS, KDW, KDX, LHL	
2	PAOZZ	5305013665120	57045	62822BB	SETSCREW.	2
					UOC: KDS, KDW, KDX, LHL	
3	PAOZZ	5305014397155	18068	23183- 002	THUMBSCREW.	1
					UOC: KDS, KDW, KDX, LHL	
4	PAOZZ	5965009371851	81349	MIL- M- 26542/10	MICROPHONE ELEMENT - WHEN REPLACING DEFECTIVE MICROPHONE BE SURE TO RETAIN THE MICROPHONE CABLE (A3206367- 1) FIG 11, ITEM 6. THE REPLACEMENT MICROPHONE (MIL- M- 26542/10) CONSISTS OF A MICROPHONE ELEMENT, BOOM ASSEMBLY, AND MICROPHONE CABLE. RETAIN THE BOOM ASSEMBLY AS A SPARE BUT DISCARD THE MICROPHONE CABLE AS IT CANNOT BE USED WITH THIS HEADSET.	1
					UOC: KDW, KDX	
5	PAOZZ	5340014439067	80063	A3206354	CLIP, RETAINING.	1
					UOC: KDS, KDW, KDX, LHL	
6	PAOZZ	5995014491098	80063	A3206367- 1	CABLE ASSEMBLY, SPEC.	1
					UOC: KDX	

END OF FIGURE

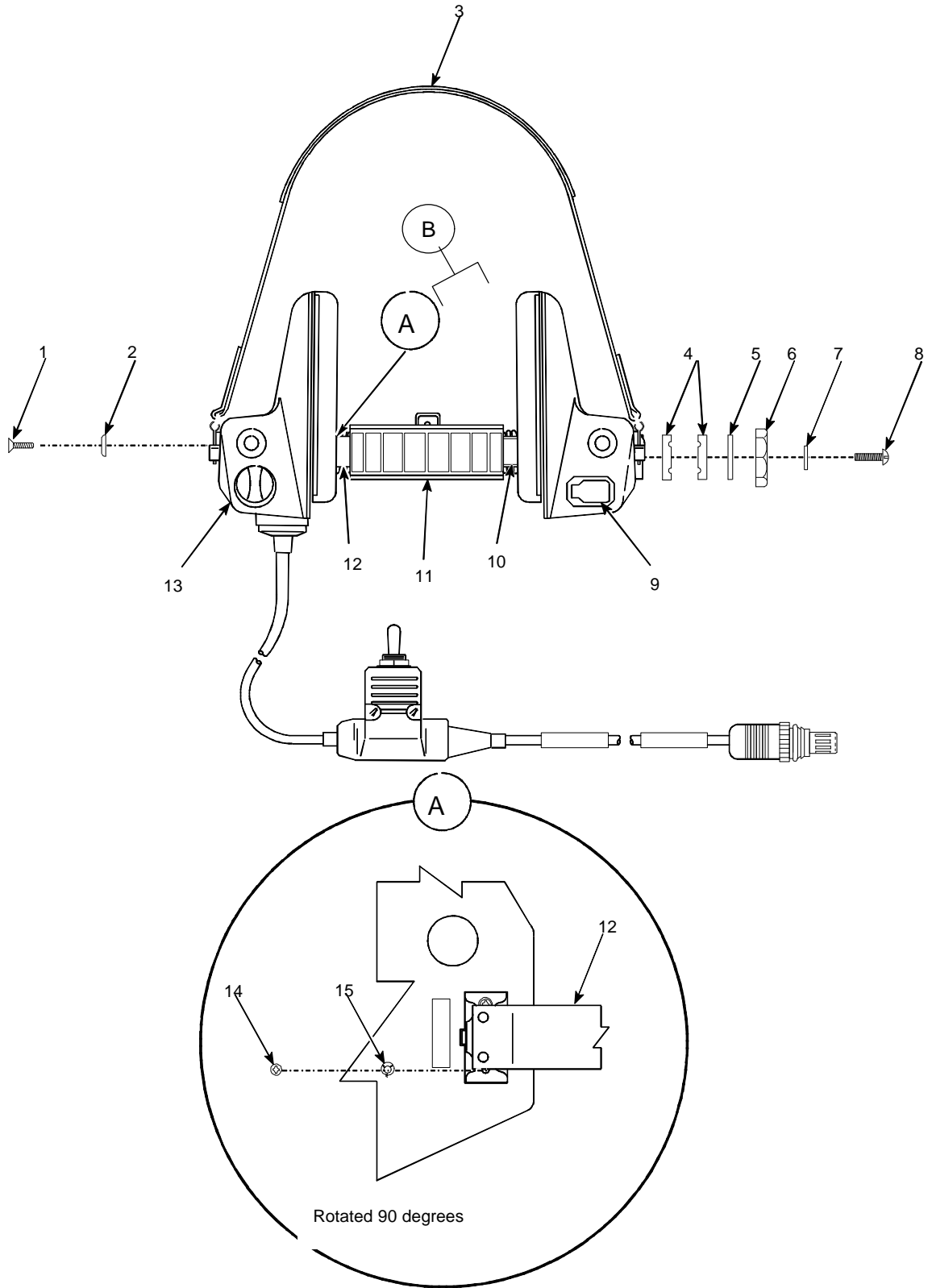

Figure 12. Headset Electrical Assembly H-365/VRC (Sheet 1 of 2)

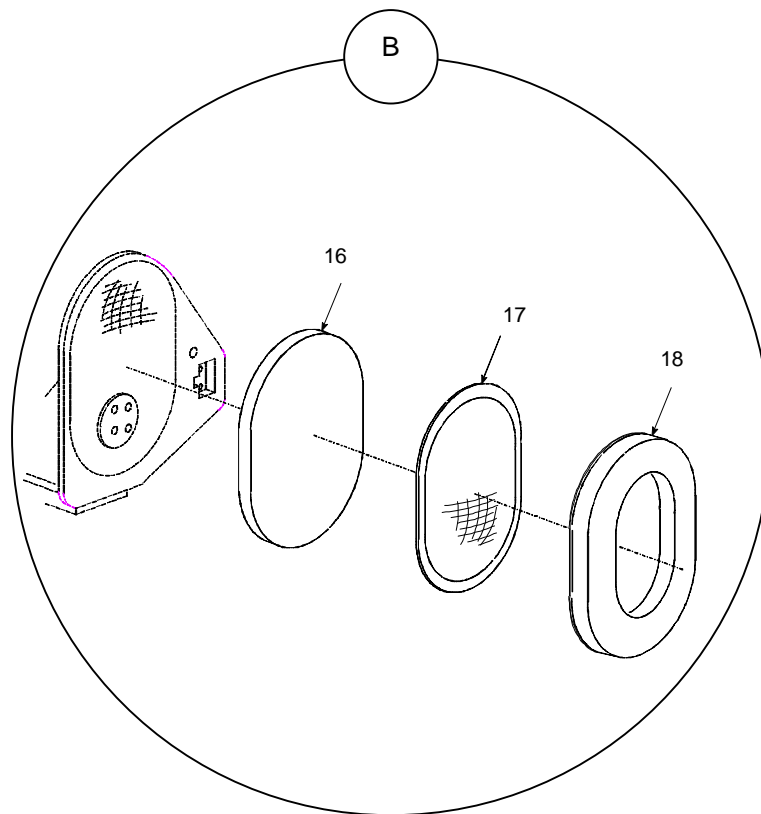

Figure 12. Headset Electrical Assembly H-365/VRC (Sheet 2 of 2)

SECTION II		TM 11-5830-263-20&P			(6)	(7)
(1)	(2)	(3)	(4)	(5)		
ITEM NO	SMR CODE	NSN	CAGEC	PART NUMBER	DESCRIPTION AND USABLE ON CODES(UOC)	QTY
GROUP 08 HEADSET-ELECTRICAL ASSEMBLY H-365/VRC						
FIG. 12						
1	PAOZZ	5305014185490	80063	A3206418	SCREW,MACHINE.....	2
					UOC:KDS,KDX,LHL	
2	PAOZZ	5310014185489	80063	A3206417	WASHER,FLAT.....	2
					UOC:KDS,KDX,LHL	
3	PAOZZ	5965014184369	80063	A3206361	HEADBAND,HEADSET.....	1
					UOC:KDS,KDX,LHL	
4	PAOZZ	5310014493249	80063	A3206541	WASHER,SLOTTED.....	2
					UOC:KDS,KDX,LHL	
5	PAOZZ	5310014491099	80063	A3206540	WASHER,SHOULDERED.....	1
					UOC:KDS,KDX,LHL	
6	PAOZZ	5355014184375	80063	A3206424	K N O B.....	1
					UOC:KDS,KDX,LHL	
7	PAOZZ	5310014491096	80063	A3206539	WASHER BLANK.....	1
					UOC:KDS,KDX,LHL	
8	PAOZZ	6305014184378	80063	A3206423	SCREW.EXTERNALLY RE.....	1
					UOC:KDS,KDX,LHL	
9	PAOZZ	5935014491091	80063	A3208375	DUMMY PLUG,TELEPHON.....	1
					UOC:KDS, LHL	
10	XBOZZ		80063	A3208384	LABEL,IDENT -SEE SB 11-631 FOR INSTRUCTIONS.....	1
					UOC:KDS,LHL	
11	PAOZZ	8415014222243	80063	A3206347	PAD,HELMET NAPE STR.	1
					UOC:KDS,KDX,LHL	
12	PAOZZ	5340014184377	80063	A3206348	HOLDER,SPRING.....	1
					UOC:KDS,KDX,LHL	
13	XAOZZ	5965014491095	80063	A3206430	HEADSET,ELECTRICAL..	1
					UOC:KDS,LHL	
14	PAOZZ	5305014185488	80063	A3206419	SCREW,EXTERNALLY RE.	4
					UOC:KDS,KDX,LHL	
15	PAOZZ	6310014491097	80063	A3206571	WASHER, CONCAVE	4
					UOC:KDS,KDX,LHL	
16	PAOZZ	8415014222250	80063	A3206430-4	PAD,CUSHIONING	2
					UOC:KDS,KDX,LHL	
17	PAOZZ		80063	A3206430-3	COVER,DIAPHRAGM.....	2
					UOC:KDS,KDX,LHL	
18	PAOZZ	5965014184373	80063	A3206430-2	CUSHION,EAR:.....	2
					UOC:KDS,KDX,LHL	

END OF FIGURE

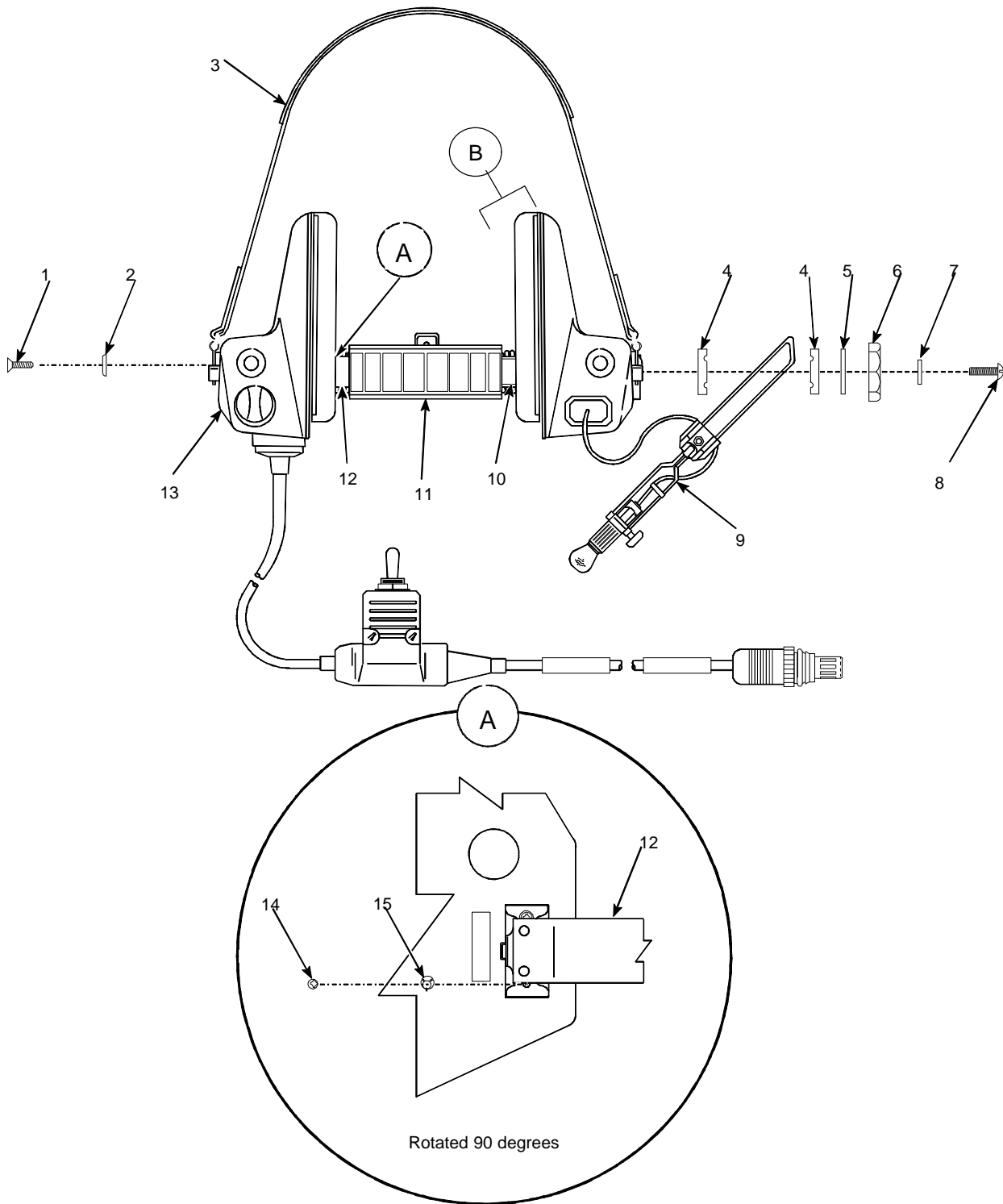

Figure 13. Headset, Microphone H-366/VRC (Sheet 1 of 2)

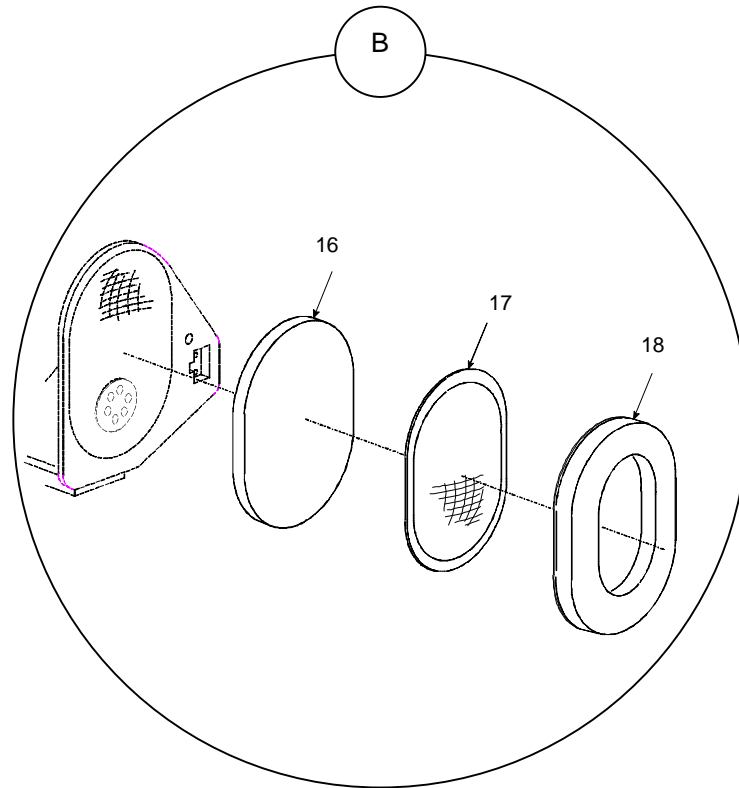

Figure 13. Headset, Microphone H-366/VRC (Sheet 2 of 2)

SECTION II			TM 11-5830-263-20&P			
(1)	(2)	(3)	(4)	(5)	(6)	(7)
ITEM NO	SMR CODE	NSN	CAGEC	PART NUMBER	DESCRIPTION AND USABLE ON CODES(UOC)	QTY
					GROUP 09 HEADSET-MICROPHONE H-366/VRC	
					FIG. 13	
1	PAOZZ	5306014185490	80063	A3206418	SCREW,MACHINE..... UOC:KDS,KDX,LHL	2
2	PAOZZ	5310014185489	80063	A3206417	WASHER,FLAT..... UOC:KDS,KDX,LHL	2
3	PAOZZ	5985014184369	80063	A3206361	HEADBAND,HEADSET..... UOC:KDS,KDX,LHL	1
4	PAOZZ	5310014493249	80063	A3206541	WASHER,SLOTTED..... UOC:KDS,KDX,LHL	2
5	PAOZZ	5310014491099	80063	A3206540	WASHER,SHOULDERED..... UOC:KDS,KDX,LHL	1
6	PAOZZ	5355014184375	80063	A3206424	KN O B..... UOC:KDS,KDX,LHL	1
7	PAOZZ	5310014491096	80063	A3206539	W A S H E R B L A N K..... UOC:KDS,KDX,LHL	1
8	PAOZZ	5305014184378	80063	A3206423	SCREW, EXTERNALLY R E..... UOC:KDS,KDX,LHL	1
9	PADQD	5965014198200	80063	A3206363	BOOM, MICROPHONE - SEE FIGURE C-14 FOR P A R T S..... UOC:KDS,LHL	1
10	XBOZZ		80063	A3206385	LABEL, IDENT -SEE SB 11-631 FOR INSTRUCTIONS..... UOC:KDS,LHL	
11	PAOZZ	8415014222243	80063	A3206347	PAD,HELMET N A P E S T R..... UOC:KDS,KDX,LHL	1
12	PAOZZ	5340014184377	80063	A3206348	HOLDER,SPRING..... UOC:KDS,KDX,LHL	1
13	XAOZZ	5965014491095	80063	A3206430	HEADSET,ELECTRICAL..... UOC:KDS,LHL	1
14	PAOZZ	5305014185488	80063	A3206419	SCREW,EXTERNALLY R E..... UOC:KDS,KDX,LHL	4
15	PAOZZ	5310014491097	80063	A3206571	WASHER,CONCAVE..... UOC:KDS,KDX,LHL	4
16	PAOZZ	8415014222250	80063	A3206430-4	PAD,CUSHIONING..... UOC:KDS,KDX,LHL	2
17	PAOZZ		80063	A3206430-3	COVER,DIAPHRAGM..... UOC: KDS,KDX,LHL	2
18	PAOZZ	5965014184373	80063	A3206430-2	CUSHION,EAR..... UOC: KDS,KDX,LHL	2

END OF FIGURE

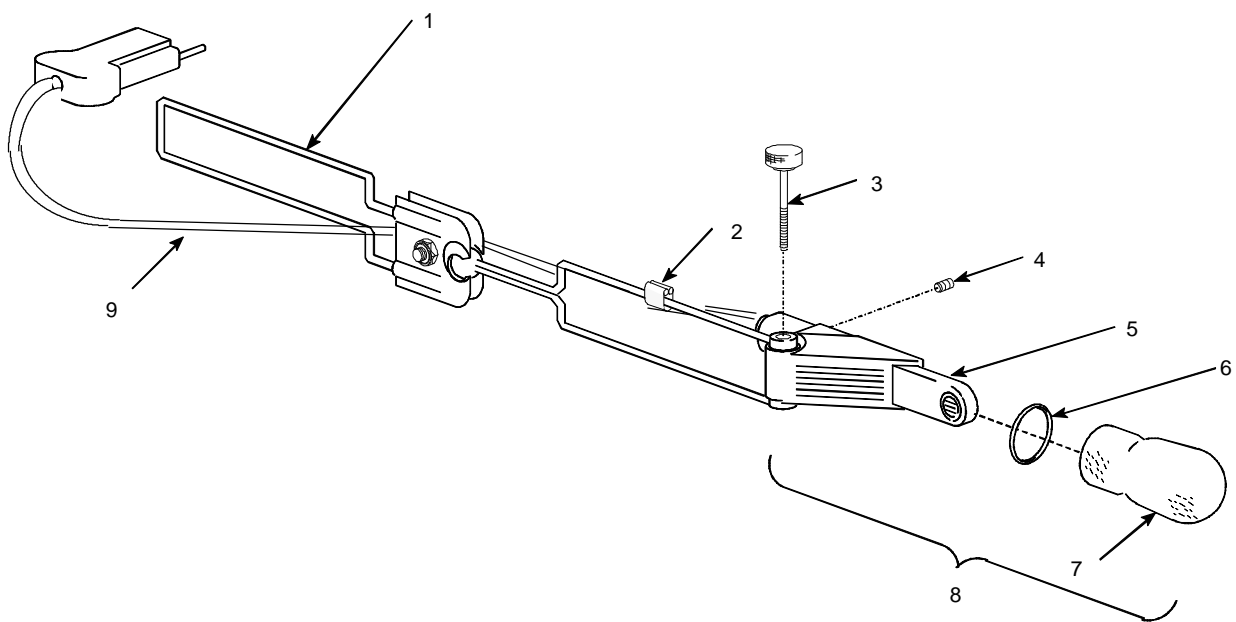

Figure 14. Microphone, Boom and Cable Assembly M-172/VRC

SECTION II

TM 11-5830-263-20&P

(1) ITEM NO	(2) SMR CODE	(3) NSN	(4) CAGEC	(5) PART NUMBER	(6) DESCRIPTION AND USABLE ON CODES(UOC)	(7) QTY
					GROUP 0901 MICROPHONE, BOOM, AND CABLE ASSEMBLY M-172/VRC	
FIG. 14						
1	PA0ZZ	5965010497236	80063	A3206358	BOOM, MICROPHONE UOC:KDS,KDW,KDX,LHL	1
2	PA0ZZ	5340014439067	80063	A3206354	CLIP, RETAINING UOC:KDS,KDW,KDX,LHL	1
3	PA0ZZ	5305014397155	18068	23183-002	THUMB SCREW UOC:KDS,KDW,KDX,LHL	1
4	PA0ZZ	5305013665120	57045	62822BB	SET SCREW UOC:KDS,KDW,KDX,LHL	2
5	XA0ZZ		80063	A3206573	MICROPHONE, CAPACIT - REPLACE DEFECTIVE MICROPHONE, CAPACITOR BY REQUISITIONING ITEM 8 OF THIS GROUP/ILLUSTRATION UOC:KDS,LHL	1
6	PA0ZZ	5330002483836	96906	MS29513-012	O - R I N G UOC:KDS,LHL	1
7	PA0ZZ	5965014111856	80063	A3206355-1	SHIELD, MICROPHONE UOC:KDS,LHL	1
8	PA0ZZ	5965014184371	80063	A3206355	MICROPHONE ELEMENT - CONSISTS OF MICROPHONE ELEMENT, O-RING, AND MICROPHONE SHIELD UOC:KDS,LHL	1
9	PA0ZZ	5995014184367	80063	A3206191	CABLE ASSEMBLY, SPEC UOC:KDS,LHL	1

END OF FIGURE

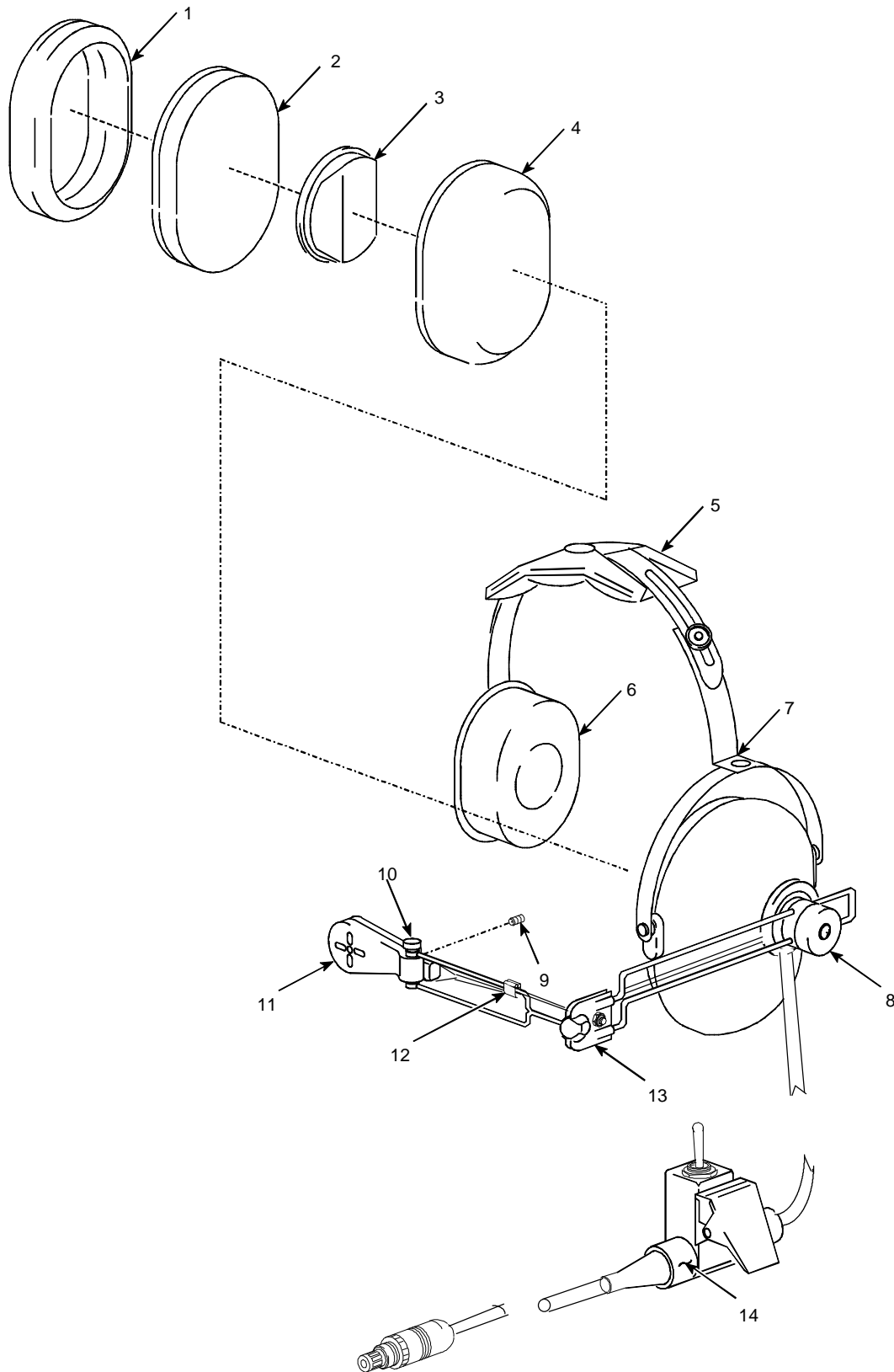

Figure 15. Headset Microphone H-364/VRC

SECTION II

TM 11-5830-263-20&P

(1) ITEM NO	(2) SMR CODE	(3) NSN	(4) CAGEC	(5) PART NUMBER	(6) DESCRIPTION AND USABLE ON CODES(UOC)	(7) QTY
GROUP 10 HEADSET-MICROPHONE H-364/VRC						
FIG. 15						
1	PAOZZ	5965014184378	80063	A3206377	CUSHION,EAR.....	1
					UOC:KDW,KDX	
2	PAOZZ	5965014184374	80063	A3206378	EARPHONE ELEMENT.....	1
					UOC:KDW,KDX	
3	PAOZZ	5965014184380	80063	A3206379	EARPHONE.....	1
					UOC:KDW,KDX	
4	PAOZZ	8415014222246	80063	A3206376	PAD,HELMET.....	1
					UOC:KDW,KDX	
5	PAOZZ	5340014501370	80063	A3206563	PAD,CUSHIONING.....	1
					UOC:KDW,KDX	
6	PAOZZ	5965014491101	80063	A3206562	CUSHION,EAR.....	1
					UOC:KDW,KDX	
7	XAOZZ	5965014184372	80063	A3206381	HEADSET,ELECTRICAL..	1
					UOC:KDW,KDX	
8	PAOZZ	5340014440341	80063	A3206534	HARDWARE KIT,ELECTR -TO REPLACE INDIVIDUAL MOUNTING HARDWARE PIECES, THE ENTIRE MOUNTING KIT MUST BE REQUISITIONED.....	
					UOC:KDW,KDX	
9	PAOZZ	5305013665120	57046	6282288	S E T S C R E W.....	2
					UOC:KDS,KDW,KDX,LHL	
10	PAOZZ	5306014397155	18068	23183-002	THUMBSCREW.....	1
					UOC:KDS,KDW,KDX,LHL	
11	PAOZZ	5965009371851	81349	MIL-M-26542/10	MICROPHONE ELEMENT -REPLACE DEFECTIVE MICROPHONE BY REQUISITIONING THIS ITEM. THIS ITEM CONSISTS OF A MICROPHONE ELEMENT, BOOM ASSEMBLY, AND MICROPHONE CABLE ASSEMBLY. RETAIN BOOM ASSEMBLY AS A SPARE, BUT DISCARD MICROPHONE CABLE ASSEMBLY AS IT CANNOT BE USED WITH THE HEADSET. THE MICROPHONE CABLE USED WITH THIS HEADSET IS HARDWARED IN AND CANNOT BE REPLACED.....	1
					UOC:KDW,KDX	
12	PAOZZ	5340014439087	80063	A3206354	CLIP,RETAINING.....	1
					UOC:KDS,KDW,KDX,LHL	
13	PAOZZ	5965010497236	80063	A3206358	BOOM,MICROPHONE..	1
					UOC:KDS,KDW,KDX,LHL	
14	XBOZZ		80063	A3206388	LABEL, IDENT -SEE SB 11-831 FOR INSTRUCTIONS.....	1
					UOC:KDW,KDX	

END OF FIGURE

CROSS-REFERENCE INDEXES

STOCK NUMBER	NATIONAL STOCK NUMBER INDEX		STOCK NUMBER	NATIONAL STOCK NUMBER INDEX	
	FIG.	ITEM		FIG.	ITEM
5310-00-044-6477	1	44	5310-00-880-7746	1	12
5310-00-045-4007	5	2		1	12
5305-00-068-0516	1	26	5310-00-889-2527	1	20
5310-00-080-6004	5	6		1	20
5310-00-081-4219	1	14		1	20
	1	14	5310-00-889-2528	1	27
	1	14		1	27
	1	14	5305-00-889-3000	5	1
	1	14	5310-00-931-8187	1	39
	1	14	5965-00-937-1851	11	4
	1	14		15	11
	1	14	5310-00-984-3806	1	15
	1	14		1	15
	1	14		1	15
5310-00-167-0721	1	13		1	15
	1	13		1	15
	1	13	5965-01-049-7236	11	1
	1	13		14	1
	1	13		15	13
5305-00-225-3843	1	21	5306-01-075-8519	1	24
	1	21		1	24
	1	21		1	24
5305-00-225-9091	1	19		1	24
5305-00-225-9093	1	41	5310-01-080-2211	5	4
5306-00-226-4830	1	29	5310-01-103-6042	1	23
	1	29		1	23
	1	29		1	23
5330-00-248-3836	8	1	5830-01-382-3209	1	4
	14	6		1	4
5310-00-407-9566	1	32	5830-01-382-3218	1	2
5305-00-489-0742	6	4		1	2
5310-00-514-6674	1	38		1	2
5310-00-550-1130	1	22		1	2
	1	22		1	2
5310-00-582-5965	1	33	5895-01-382-3220	1	3
5310-00-596-7693	1	40		1	3
5310-00-616-3056	1	42	5895-01-382-3221	1	1
5355-00-616-9659	2	3	5965-01-382-3222	1	5
	3	3	5965-01-385-7811	1	8
	4	3		1	8
5310-00-637-9541	5	5	5965-01-385-7813	1	9
5310-00-728-2044	1	35	5995-01-386-9109	1	11G
5310-00-761-6882	1	36		1	11G
5310-00-768-0319	1	31		1	11G
5310-00-809-4058	1	28		1	11G
5310-00-829-9981	1	34		1	11G
5310-00-880-7744	1	17		1	11G
5310-00-880-7746	1	12	5995-01-386-9116	1	11F
	1	12	5965-01-386-9134	1	10
	1	12	5965-01-388-4181	1	7

CROSS-REFERENCE INDEXES

		NATIONAL STOCK NUMBER INDEX			
STOCK NUMBER	FIG.	ITEM	STOCK NUMBER	FIG.	ITEM
5995-01-392-6196	1	11B	5995-01-406-1174	1	11K
	1	11B	5995-01-406-1175	1	11K
5995-01-392-6197	1	11B	5995-01-406-1176	1	11N
5995-01-392-6198	1	11B	5995-01-406-1177	1	11M
	1	11B	5995-01-406-1178	1	11L
	1	11B	5995-01-406-1179	1	11L
5995-01-392-6199	1	11B	5995-01-406-1181	1	11J
	1	11B	5995-01-406-1183	1	11D
5995-01-392-6200	1	11B	5995-01-407-1230	1	11B
5995-01-392-6201	1	11B	5995-01-407-1231	1	110
	1	11B	5995-01-407-1233	1	110
5995-01-392-6202	1	11B	5965-01-411-1856	14	7
	1	11B	5999-01-412-1339	1	16
5995-01-392-6203	1	11B		1	16
	1	11B		1	16
5995-01-392-6204	1	11B		1	16
	1	11B		1	16
5995-01-392-7319	1	11C		1	16
5995-01-392-7320	1	11C	5999-01-412-1341	1	25
5995-01-392-7321	1	11C		1	25
5995-01-392-7322	1	11C		1	25
5995-01-392-7323	1	11A	5999-01-412-1342	1	18
5995-01-392-7325	1	11H	5995-01-418-4367	14	9
5995-01-392-7326	1	11A	5965-01-418-4369	10	3
	1	11A		12	3
5995-01-392-7352	1	11B		13	3
5995-01-392-7356	1	11B	5965-01-418-4371	14	8
5995-01-392-7358	1	11C	5965-01-418-4373	10	18
5995-01-392-7359	1	11A		12	18
	1	11A		13	18
	1	11A	8415-01-418-4374	15	2
	1	11A	5355-01-418-4375	10	6
5995-01-392-7362	1	11E		12	6
5995-01-392-7363	1	11E		13	6
5995-01-392-7364	1	11A	5965-01-418-4376	15	1
5995-01-392-7365	1	11A	5340-01-418-4377	10	12
5995-01-392-9106	1	11A		12	12
5995-01-392-9107	1	11A		13	12
5995-01-392-9114	1	11B	5305-01-418-4378	10	8
5995-01-393-0216	1	11I		12	8
5995-01-393-7694	1	11I		13	8
5965-01-397-7542	1	6	5965-01-418-4380	15	3
5965-01-397-7544	1	6	5305-01-418-5488	10	14
	1	6		12	14
5965-01-398-1551	1	6		13	14
	1	6	5310-01-418-5489	10	2
5995-01-406-1171	1	11B		12	2
5995-01-406-1172	1	11B		13	2
	1	11B	5305-01-418-5490	10	1
5995-01-406-1173	1	11A		12	1

CROSS-REFERENCE INDEXES

STOCK NUMBER	NATIONAL STOCK NUMBER INDEX		STOCK NUMBER	FIG.	ITEM
	FIG.	ITEM			
5305-01-418-5490	13	1	5995-01-452-4310	1	11A
5965-01-418-5535	7	1	5310-01-455-1831	2	2
5955-01-419-8196	6	2A		3	2
5965-01-419-8200	13	9		4	2
8415-01-422-2243	10	11	5995-01-455-4211	1	11A
	12	11	5995-01-455-4213	1	11A
	13	11		1	11A
8415-01-422-2246	15	4	5995-01-456-8955	1	11T
8415-01-422-2250	10	16	5305-01-457-3848	2	1
	12	16		3	1
	13	16		4	1
5995-01-422-4683	1	11L	5995-01-458-5334	1	11A
5995-01-426-1354	1	110	5995-01-458-6014	1	11B
5995-01-428-5177	1	11G	5995-01-458-8461	1	11A
	1	11G	5995-01-458-8464	1	11A
	1	11G	5999-01-459-0532	1	37
5995-01-433-1228	1	11R	5995-01-459-3791	1	118
5995-01-433-1229	1	11Q	5995-01-462-0374	1	11S
5305-01-439-7155	11	3	5965-01-462-4079	6	3
	14	3	5995-01-463-5655	1	11U
	15	10	5995-01-463-5657	1	110
5310-01-443-9063	6	6	5995-01-463-5658	1	110
5310-01-443-9064	6	5	5995-01-463-5659	1	11B
5340-01-443-9067	11	5	5965-01-464-0220	6	28
	14	2	6160-01-464-0221	7	8
	15	12	5895-01-464-0223	7	2
5935-01-443-9068	1	11P	5930-01-464-9981	7	4
5340-01-444-0341	15	8	5930-01-464-9985	7	5
5310-01-444-6389	6	7			
5935-01-449-1091	12	9			
5965-01-449-1092	10	9			
5310-01-449-1096	10	7			
	12	7			
	13	7			
5310-01-449-1097	10	15			
	12	15			
	13	15			
5995-01-449-1098	11	6			
5310-01-449-1099	10	5			
	12	5			
	13	5			
5965-01-449-1101	15	6			
5310-01-449-3249	10	4			
	12	4			
	13	4			
5340-01-450-1370	15	5			
5355-01-451-9354	5	3			
5995-01-452-4307	1	11B			
5995-01-452-4308	1	11B			
5995-01-452-4309	1	11A			

CROSS-REFERENCE INDEXES

CAGEC	PART NUMBER	PART NUMBER INDEX		FIG.	ITEM
			STOCK NUMBER		
80063	A3205937		5305-01-457-3848	2	1
				3	1
				4	1
80063	A3205978		5310-01-455-1831	2	2
				3	2
				4	2
80063	A3206017-10		5995-01-458-8464	1	11A
80063	A3206017-12		5995-01-406-1173	1	11A
80063	A3206017-3		5995-01-452-4309	1	11A
80063	A3206017-4		5995-01-455-4211	1	11A
80063	A3206017-5		5995-01-392-9106	1	11A
80063	A3206017-6		5995-01-392-9107	1	11A
80063	A3206017-7		5995-01-392-7323	1	11A
80083	A3206018-10		5995-01-406-1171	1	11B
80063	A3206018-11		5995-01-463-5659	1	11B
80063	A3206018-12		5995-01-392-6204	1	11B
				1	11B
80063	A3206018-13		5995-01-458-6014	1	11B
80063	A3206018-15		5995-01-392-6200	1	11B
80063	A3206018-16		5995-01-392-6201	1	11B
				1	11B
80063	A3206018-17		5995-01-459-3791	1	11B
80063	A3206018-18		5995-01-452-4307	1	11B
80063	A3206018-19		5995-01-392-7356	1	11B
80063	A3206018-2		5995-01-392-6196	1	11B
				1	11B
80063	A3206018-20		5995-01-392-9114	1	11B
80063	A3206018-21		5995-01-392-7352	1	11B
80063	A3206018-24		5995-01-452-4308	1	11B
80063	A3206018-3		5995-01-407-1230	1	11B
80063	A3206018-4		5995-01-392-6202	1	11B
				1	11B
80063	A3206018-5		5995-01-392-6199	1	11B
				1	11B
80063	A3206018-6		5995-01-392-6197	1	11B
80063	A3206018-7		5995-01-392-6198	1	11B
				1	11B
80063	A3206018-8		5995-01-392-6203	1	11B
				1	11B
80063	A3206018-9		5995-01-406-1172	1	11B
				1	11B
80063	A3206019-10		5995-01-458-8461	1	11A
80063	A3206019-12		5995-01-392-7365	1	11A
80063	A3206019-2		5995-01-452-4310	1	11A
80063	A3206019-3		5995-01-458-5334	1	11A
80063	A3206019-4		5995-01-455-4213	1	11A
				1	11A
80063	A3206019-6		5995-01-392-7359	1	11A
				1	11A
				1	11A

		CROSS-REFERENCE		INDEXES			
CAGEC	PART NUMBER	PART NUMBER	INDEX STOCK	INDEX NUMBER	FIG.	ITEM	
80063	A3206019-6		5995-01-392-7359		1	11A	
80063	A3206019-9		5995-01-392-7364		1	11A	
80063	A3206020		5995-01-386-9109		1	11G	
					1	11G	
					1	11G	
					1	11G	
					1	11G	
					1	11G	
B0063	A3206021-1		5995-01-392-7362		1	11E	
80063	A3206021-19		5995-01-392-7363		1	11E	
80063	A3206023-13-16		5995-01-392-7358		1	11C	
80063	A3206081-3-3		5995-01-392-7319		1	11C	
80063	A3206102-4-4		5995-01-392-7320		1	11C	
80063	A3206116		5995-01-392-7325		1	11H	
80063	A3206118		5995-01-386-9116		1	11F	
80063	A3206120-3-3		5995-01-392-7321		1	11C	
80063	A3206121-4-5		5995-01-392-7322		1	11C	
80063	A3206127-6		5995-01-392-7326		1	11A	
					1	11A	
80063	A3206129-2		5995-01-422-4683		1	11L	
80063	A3206130-I0		5995-01-406-1176		1	11N	
80063	A3206131		5999-01-412-1342		1	18	
80063	A3206132		5999-01-412-1339		1	16	
					1	16	
					1	16	
					1	16	
					1	16	
					1	16	
80063	A3206133		5999-01-412-1341		1	25	
					1	25	
					1	25	
80063	A3206191		5995-01-418-4367		14	9	
80063	A3206193-30		5995-01-393-0216		1	11I	
80063	A3206193-6		5995-01-393-7694		1	11I	
80063	A3206249-16		5995-01-406-1175		1	11K	
80063	A3206249-3		5995-01-406-1174		1	11K	
80063	A3206257-16-17		5995-01-426-1354		1	110	
80063	A3206257-16-21		5995-01-407-1231		1	110	
80063	A3206257-16-25		5995-01-407-1233		1	110	
80063	A3206307-30		5995-01-406-1178		1	11L	
80063	A3206307-6		5995-01-406-1179		1	11L	
80063	A3206308-30		5995-01-406-1183		1	11D	
80063	A3206309-2		5995-01-406-1181		1	11J	
B0063	A3206317-25		5995-01-406-1177		1	11M	
26512	A3206345		5965-01-411-1856		8	2	
80063	A3206347		8415-01-422-2243		10	11	
					12	11	
					13	11	
80063	A3206348		5340-01-418-4377		10	12	
					12	12	
					13	12	

CROSS-REFERENCE INDEXES

CAGEC	PART NUMBER	PART NUMBER INDEX STOCK NUMBER	FIG.	ITEM
80063	A3206354	5340-01-443-9067	11	5
			14	2
			15	12
80063	A3206355	5965-01-418-4371	14	8
80063	A3206355-1	5965-01-411-1856	14	7
80063	A3206358	5965-01-049-7236	11	1
			14	1
			15	13
80063	A3206361	5965-01-418-4369	10	3
			12	3
			13	3
80063	A3206363	5965-01-419-8200	13	9
80063	A3206367	5965-01-449-1092	10	9
80063	A3206367-1	5995-01-449-1098	11	6
80063	A3206368		10	13
80063	A3206375	5935-01-449-1091	12	9
80063	A3206376	8415-01-422-2246	15	4
80063	A3206377	5965-01-418-4376	15	1
80063	A3206378	8415-01-418-4374	15	2
80063	A3208379	5965-01-418-4380	15	3
80063	A3206381		15	7
80063	A3206384		12	10
80063	A3206385		13	10
80063	A3206387		10	10
80063	A3206388		15	14
80063	A3206414	5965-01-419-8196	6	2A
80063	A3206414-1		7	3
80063	A3206417	5310-01-418-5489	10	2
			12	2
			13	2
80063	A3206418	5305-01-418-5490	10	1
			12	1
			13	1
80063	A3206419	5305-01-418-5488	10	14
			12	14
			13	14
80063	A3206423	5305-01-418-4378	10	8
			12	8
			13	8
80063	A3206424	5355-01-418-4375	10	6
			12	6
			13	6
80063	A3206430		12	13
			13	13
80063	A3206430-2	5965-01-418-4373	10	18
			12	18
			13	18
80063	A3206430-3		10	17
			12	17
			13	17
80063	A3206430-4	8415-01-422-2250	10	16

SECTION IV

TM 11 - 5830-263-20&P

CROSS-REFERENCE INDEXES

CAGEC	PART NUMBER	PART NUMBER INDEX STOCK NUMBER	FIG.	ITEM
80063	A3206430-4	8415-01-422-2250	12	16
			13	16
80063	A3206444	5995-01-429-5177	1	11G
			1	11G
			1	11G
80063	A3206455	5310-01-444-6389	6	7
80063	A3206456	5310-01-443-9063	6	6
80063	A3206457	5310-01-443-9064	6	5
80063	A3206461-5-12	5995-01-433-1229	1	11Q
80063	A3206463	5995-01-433-1228	1	11R
80063	A3206465	5935-01-443-9068	1	11P
80063	A3206534	5340-01-444-0341	15	8
80063	A3206539	5310-01-449-1096	10	7
			12	7
			13	7
80063	A3206540	5310-01-449-1099	10	5
			12	5
			13	5
80063	A3206541	5310-01-449-3249	10	4
			12	4
			13	4
80063	A3206562	5965-01-449-1101	15	6
80063	A3206563	5340-01-450-1370	15	5
80063	A3206571	5310-01-449-1097	10	15
			12	15
			13	15
80063	A3206573		14	5
80063	A3206613	5965-01-464-0220	6	28
80063	A3206613-1		7	7
80063	A3206613-2	5895-01-464-0223	7	2
80063	A3206613-3	5965-01-418-5535	7	1
80063	A3206613-4	6160-01-464-0221	7	8
80063	A3206613-5	5930-01-464-9981	7	4
80063	A3206613-6	5930-01-464-9985	7	5
80063	A3206616	5965-01-462-4079	6	3
80063	A3206617-2		6	1A
80063	A3206617-22		9	1A
80063	A3206617-23		9	1B
80063	A3206617-3		6	1B
80063	A3206618	5995-01-462-0374	1	11S
80063	A3207043	5995-01-456-8955	1	11T
80063	A3207044	5999-01-459-0532	1	37
80063	A3207046	5995-01-463-5655	1	11U
80063	A3207048-13-13	5995-01-463-5657	1	110
80063	A3207048-13-15	5995-01-463-5658	1	110
80204	B1 821 BH025C1 OON	5305-00-225-3843	1	21
			1	21
			1	21
80204	B1821 BH031 C1 38N	5306-00-226-4830	1	29
			1	29
			1	29

CROSS-REFERENCE INDEXES

CAGEC	PART NUMBER	PART NUMBER INDEX		FIG.	ITEM
		STOCK	NUMBER		
96906	MS35338-41	5310-00-045-4007		5	2
96906	MS35338-44	5310-00-582-5965		1	33
96906	MS35338-45	5310-00-407-9566		1	32
96906	MS35338-46	5310-00-637-9541		5	5
96906	MS35426-31	5310-01-080-2211		5	4
96906	MS35649-2312	5310-00-829-9981		1	34
96906	MS45904-68	5310-00-889-2528		1	27
				1	27
96906	MS45904-72	5310-00-889-2527		1	20
				1	20
				1	20
96906	MS45904-73	5310-00-728-2044		1	35
96906	MS51412-25	5310-00-044-6477		1	44
96906	MS51412-4	5310-01-103-6042		1	23
				1	23
				1	23
96906	MS51922-9	5310-00-984-3806		1	15
				1	15
				1	15
96906	MS51957-41B	5305-00-489-0742		6	4
96906	MS51967-2	5310-00-761-6882		1	36
96906	MS51967-5	5310-00-880-7744		1	17
96906	MS51967-6	5310-00-931-8167		1	39
96906	MS51968-2	5310-00-768-0319		1	31
96906	MS51968-5	5310-00-880-7746		1	12
				1	12
				1	12
				1	12
				1	12
80058	MS90725-34	5306-00-225-8499		1	30
				1	30
				1	30
96906	MS90725-36	5306-01-075-8519		1	24
				1	24
				1	24
				1	24
96906	MS90726-10	5305-00-267-8954		1	45
96906	MS90726-36	5305-00-225-9091		1	19
96906	MS90726-38	5305-00-225-9093		1	41
96906	MS90726-9	5305-00-068-0516		1	26
96906	MS91524-9AW2SOX	5355-01-451-9354		5	3
96906	MS91525-0-A-P-3-S-0-Z	5355-00-616-9659		2	3
				3	3
				4	3
81349	M45913/1-5CG5C	5310-00-984-3806		1	15
				1	15
81349	M83413/8-A021CD			1	43
32108	179544-2			7	6
18068	23183-002	5305-01-439-7155		11	3
				14	3

SECTION IV

TM 11-5830-263-20&P

CROSS-REFERENCE INDEXES

CAGEC	PART NUMBER	PART NUMBER INDEX STOCK NUMBER	FIG.	ITEM
18068	23183-002	5305-01-439-7155	15	10
57045	62822BB	5305-01-366-5120	11	2
			14	4
			15	9

APPENDIX D
COMPONENTS OF END ITEM AND BASIC ISSUE ITEMS LIST

SECTION I. INTRODUCTION

Not Applicable

SECTION II. COMPONENTS OF END ITEM LIST FOR AN/VIC-3(V)1 THROUGH AN/VIC-3(V)18

Not Applicable

SECTION III. BASIC ISSUE ITEMS FOR AN/VIC(V)1 THROUGH AN/VIC-3(V)18

TM 11-5830-263-20&P	UNIT MAINTENANCE MANUAL
---------------------	-------------------------

APPENDIX E

ADDITIONAL AUTHORIZATION LIST

SECTION I. INTRODUCTION

E-1 SCOPE

This appendix lists additional items you are authorized for the support of the AN/VIC-3(V)*.

E-2 GENERAL

This list identifies items that do not have to accompany the AN/VIC-3(V)* and that do not have to be turned in with it. These items are all authorized to you by Common Table of Allowances (CTA), Modified Table of Organization and Equipment (MTOE), Table of Distribution and Allowances (TDA), or Joint Table of Allowances (JTA).

E-3 EXPLANATION OF LISTING

National stock numbers, descriptions, and quantities are provided to help you identify and request the additional items you require to support this equipment. The items are listed in alphabetical sequence by item name under the type document (i.e., CTA, MTOE, TDA, or JTA) which authorizes the item(s) to you. If the item you require differs between serial numbers of the same model, effective serial numbers are shown in the last line of the description. If item required differs for different models of this equipment, the model is shown under the Usable on heading in the description column. These codes are identified as:

Code	Used On
KDQ	Model AN/VIC-3(V)1
KDR	Model AN/VIC-3(V)2
KDS	Model AN/VIC-3(V)3
KDT	Model AN/VIC-3(V)4
KDU	Model AN/VIC-3(V)5
KDV	Model AN/VIC-3(V)6
KDW	Model AN/VIC-3(V)7
KDX	Model AN/VIC-3(V)8
LHL	Model AN/VIC-3(V)9
LHM	Model AN/VIC-3(V)10
LUY	Model AN/VIC-3(V)11
LUZ	Model AN/VIC-3(V)12
LVA	Model AN/VIC-3(V)13
LVB	Model AN/VIC-3(V)14
LVC	Model AN/VIC-3(V)15
LVD	Model AN/VIC-3(V)16
LVE	Model AN/VIC-3(V)17
23C	Model AN/VIC-3(V)18

SECTION II. ADDITIONAL AUTHORIZATION LIST

FOR AN/VIC-3(V)1 THROUGH AN/VIC-3(V)18

Key	National stock number	Description CAGEC & part number	Usable on code	U/M	Qty auth
1.	6625-01-265-6000	Multimeter (80058), AN/PSM-45A	KDQ, KDR, KDS, KDT, KDU, KDV, KDW, KDX, LHL, LHM	EA	001
2.	5180-00-064-5178	Tool kit (80058), TK101GISSUE6	KDQ, KDR, KDS, KDT, KDU, KDV, KDW, KDX, LHL, LHM	EA	001
3.	5120-00-234-8912	Screwdriver, Cross-Tip (C7127), SSDP63	KDQ, KDR, KDS, KDT, KDU, KDV, KDW, KDX, LHL, LHM	EA	001
4.	5120-00-227-6705	Socket, Socket Wrench (72958), 523124	KDS, LHL	EA	001
5.	5120-00-060-2004	Screwdriver, Cross-Tip (24446), 7228423p1	KDS, KDV, KDW, KDX, LHL	EA	001
6.	5120-00-264-3777	Wrench, Spanner (05506), 39-4815	KDU, KDW, KDX	EA	001
7.	5120-01-336-5636	Pliers, Slip Joint (71612), 420	LVC	EA	001

APPENDIX F

EXPENDABLE/DURABLE SUPPLIES AND MATERIALS LIST

SECTION I. INTRODUCTION

F-1 Scope

This appendix lists expendable and/or durable supplies and materials you will need to operate and maintain the AN/VIC-3(V)* system. These items are authorized to you by CTA 50-970, Expendable items (Except Medical, Class V, Repair Parts, and Heraldic Items).

F-2 Explanation of Columns

- a. Column (1) - Item Number. This number is assigned to the entry in the listing for reference purposes.
- b. Column (2) - Level. This column identifies the lowest level of maintenance that requires the listed item. (enter as applicable)
 - C - Operator/Crew
 - O - Unit Maintenance
 - F - Intermediate Direct Support Maintenance
 - H - Intermediate General Support Maintenance
- c. Column (3) - National Stock Number. This is the national stock number assigned to the item; use it to request or requisition the item.
- d. Column (4) - Description. Indicates the Federal item name and, if required, description to identify the item. The last line for each item indicates the Federal Supply Code for Manufacturer (FSCM) in parentheses followed by the part number.
- e. Column (5) - Unit of Measure (U/M). Indicates the measure used in performing the actual maintenance function. This measure is expressed by a two-character alphabetical abbreviation (e.g., ea, in, pr). If the unit of measure differs from the unit of issue, requisition the lowest unit of issue that will satisfy your requirements.

**SECTION II. EXPENDABLE/DURABLE SUPPLIES AND MATERIALS
FOR AN/VIC-3(V)1 THROUGH AN/VIC-3(V)18**

(1) Item No.	(2) Level	(3) National Stock Number	(4) Description	(5) U/M
1.	C	7920-00-044-9281	Cleaning, Cloth (81349), MIL-C-85043	BX
2.	C	6810-00-292-9625	Degreasing Solvent (83574), PR146BLUE	QT
3.	C	6850-00-664-4959	Silicone Compound (71984), DC 6	GL
4.	C	7930-00-282-9699	Detergent, General Purpose (81349), MIL-D-16791	GL
5.	C	5975-01-133-8696	Strap, Tiedown (96906), MS3367-6-9	HD
6.	C	6850-00-973-9091	Penetrating Fluid (01267), DUOL	CN
7.	C	6135-00-985-7845	Battery, Non-recharge (90303), MN1500	PG
8.	C	6140-01-467-3225	Battery, Rechargeable (83740), NH15	PG

APPENDIX G

ACRONYMS AND TERMS

This Appendix provides a list of acronyms and terms used in this technical manual. Definitions of all the terms are given.

TERM	DEFINITION
ACAPS	Artillery Communication Aural Protective System
ANR	Active Noise Reduction
ARC	Auto Reconnect Circuit
ASSY	Assembly
BIT	Built-In-Test
CAPS	Communication Aural Protective System
CBR	Chemical, Biological, and Radiological Decontamination
CCA	Circuit Card Assembly
CCH	Command and Control Headset
CECOM	Communications-Electronic Command
CPM	Continuous Performance Monitoring
CPV	Command Post Vehicle
CVC	Combat Vehicle Crewman
dB	Decibels (Unit of measure for sound level)
DISREP	Discrepancy In Shipment Report
DMWR	Depot Maintenance Work Requirement
EIR	Equipment Improvement Recommendations
FFCS	Full Function Crew Station
INT	Intercom
LED	Light Emitting Diode
LIVE	Microphone on headset is always on
LS	Loudspeaker
MAC	Maintenance Allocation Chart
MCS	Master Control Station
MODULATE	Transmit over headset or field telephone
MONITOR	Receive communication over headset or loudspeaker
MOS	Monitor Only (Crew) Station
MWO	Modification Work Order
NSN	National Stock Number

TERM	DEFINITION
O/R	Override
PCB	Printed Circuit Board
PL	Parts List
PMCS	Preventative Maintenance Checks and Services
PTT	Push to Talk
RIT	Radio Interface Terminal
RO	Royal Ordnance
ROD	Report Of Discrepancy
RPSTL	Repair Parts & Special Tools List
SICPS	Standard Integrated Command Post System
SINCGARS	Single Channel Ground-to-Air Radio System
SPL	Sound Pressure Level
TAMMS	The Army Maintenance Management System
TB	Technical Bulletin
TBD	To Be Determined
TDMA	Time Division Multiple Access
TDR	Transportation Deficiency Report
TM	Technical Manual
TMDE	Test Measurement & Diagnostic Equipment
TPS	Test Program Sets
UL	Unit Level
VIS	Vehicular Intercommunication Set
WK	Work
VOX	Voice Operated Switch

APPENDIX H CABLE ASSEMBLY, CONNECTOR PIN IDENTIFICATION AND SIGNAL NAMES

CAUTION

WHEN USING THE FOLLOWING DIAGRAMS AND PICTORIALS SOME OF THE CABLES AND PIN TO PIN LAYOUTS LOOK THE SAME, DO NOT USE ANY OTHER CABLE IN THE PLACE OF THE DESIGNED CABLE IDENTIFIED IN THE VEHICLE INSTALLATION DIAGRAMS IN CHAPTER 2.

LIST OF CABLE PART NUMBERS AND COMMON NAMES

A3206017	Power Cable	Figure-1.
A3206018	Highway Cable	
A3206019	Radio Cable	
A3206020	Bailout Cable	Figure-2.
A3206021	Alarm Cable	
A3206023	Highway Cable Branched	
A3206081	Highway Cable Branched	Figure-3.
A3206102	Highway Cable Branched	
A3206116	Alarm Interface Cable	
A3206118	Highway/Digital Interface Cable	Figure-10.
A3206120	Highway Cable Branched	Figure-4.
A3206121	Highway Cable Branched	
A3206127	Radio Cable	
A3206129	Highway Cable	Figure-5.
A3206130	Highway Interface Cable	
A3206193	Loudspeaker Cable	
A3206249	Highway Cable	Figure-6.
A3206257	Highway Cable Branched	
A3206307	Highway Cable	
A3206308	Highway Cable	Figure-7.
A3206309	Highway Cable	
A3206317	Highway Cable	
A3206444	Bailout Cable	Figure-2
A3206461	Highway Cable Branched	Figure-8.
A3206463	Highway Cable Branched	
A3206465	Plug Shorting	Figure-9.
A3206618	Special Purpose Cable	Figure 11
A3207043	Bailout Cable (30 ft)	
A3207046	Special Purpose Cable	Figure 12
A3207048	Slip Ring Cable	

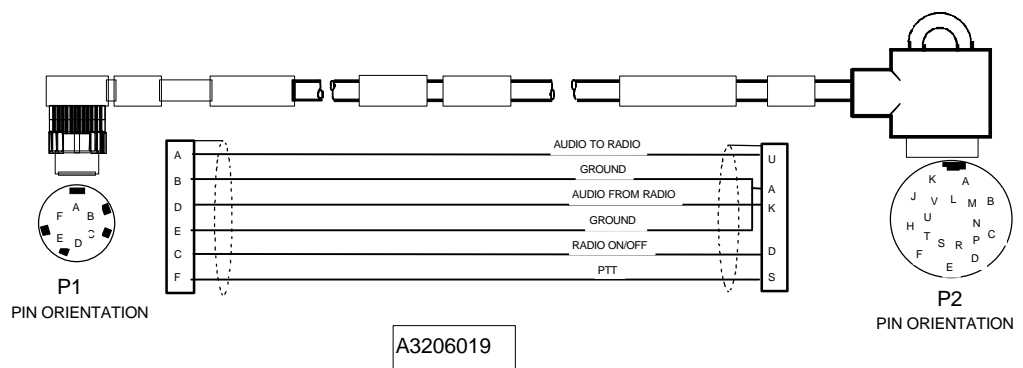
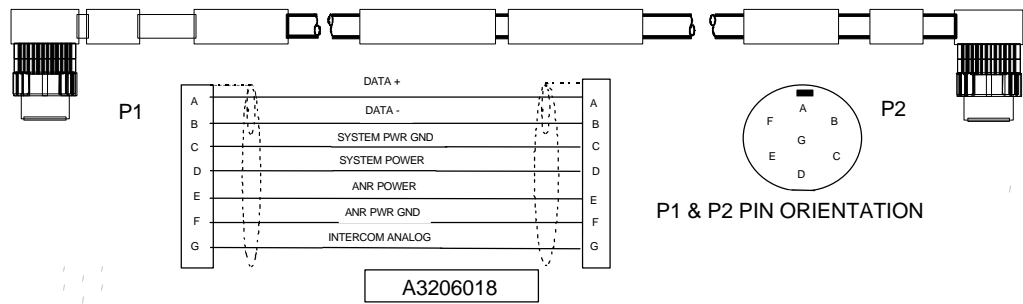
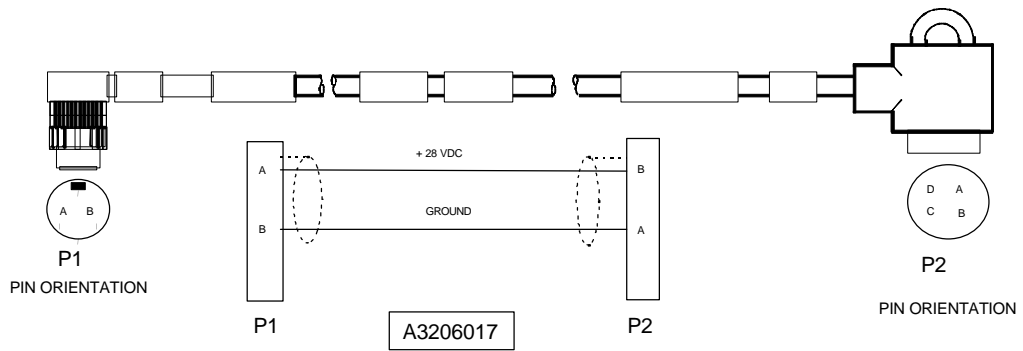

Figure-1. A3206017, A3206018, A3206019

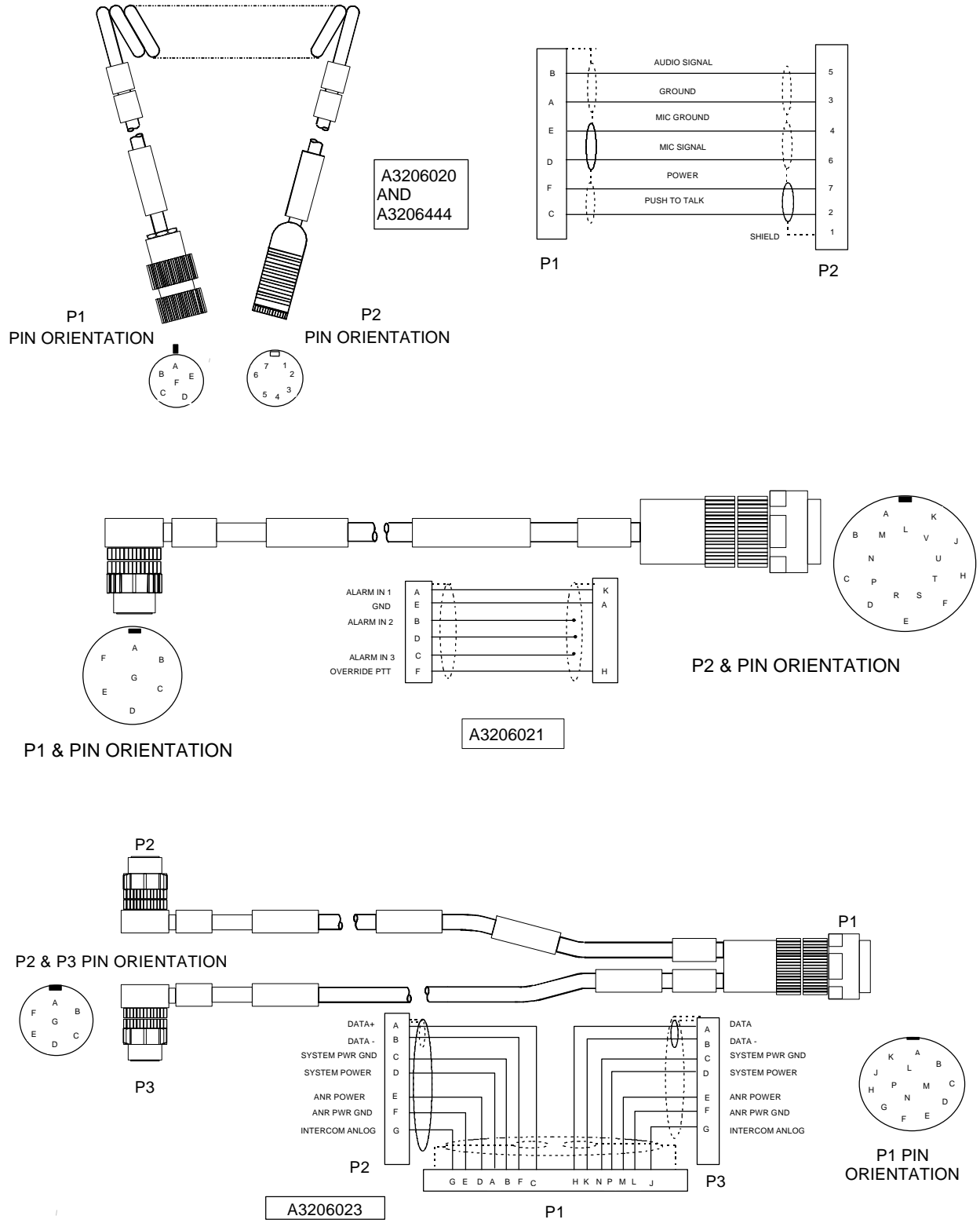

Figure-2. A3206020, A3206444, A3206021, A3206023

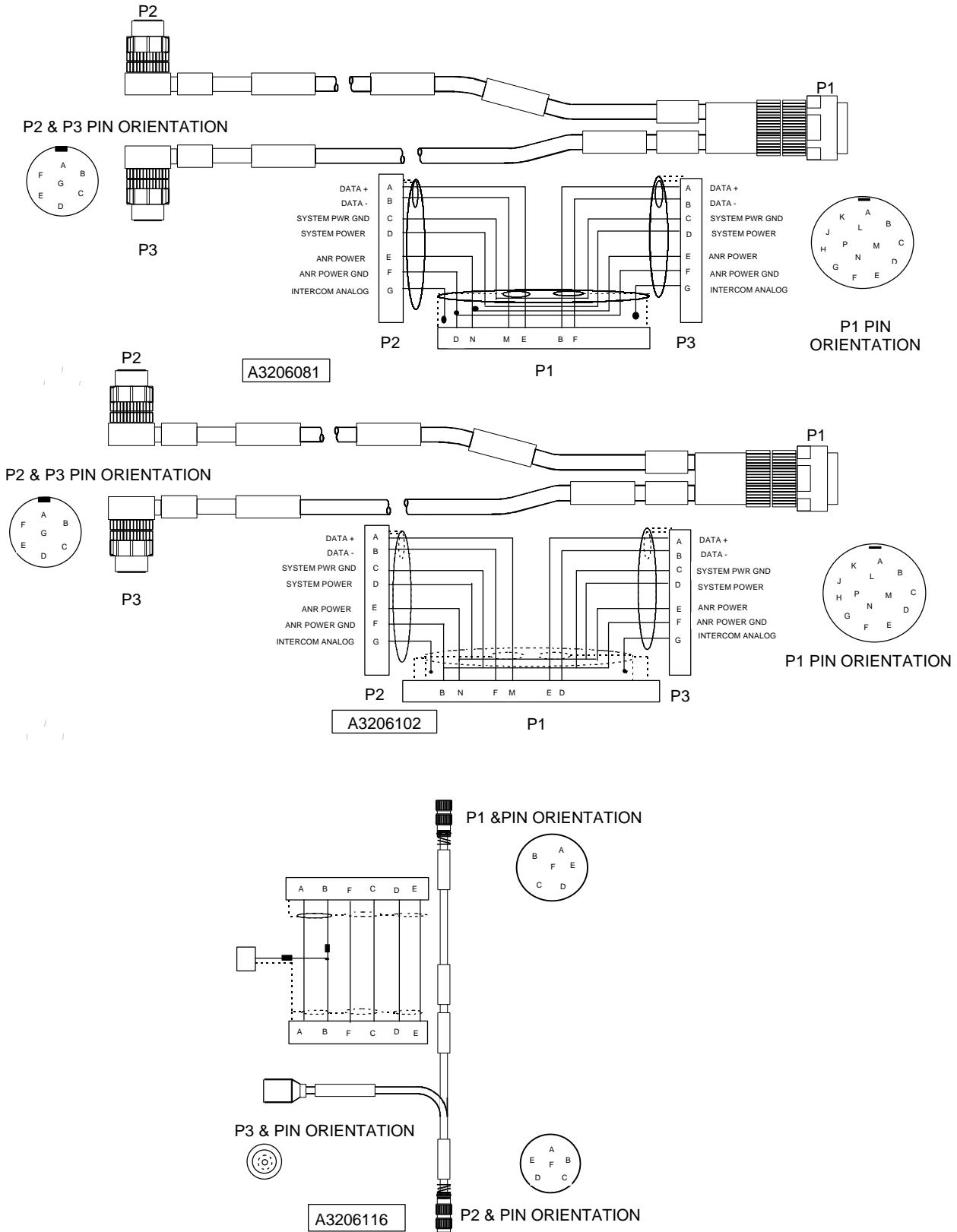

Figure-3. A3206081, A3206102, A3206116

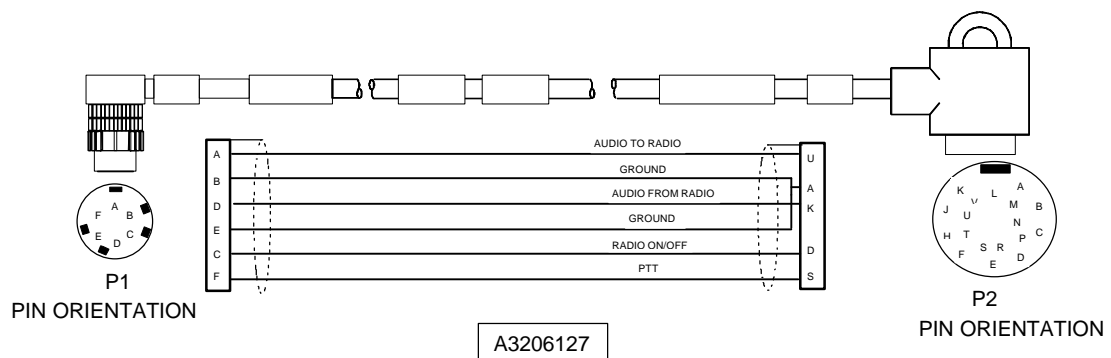
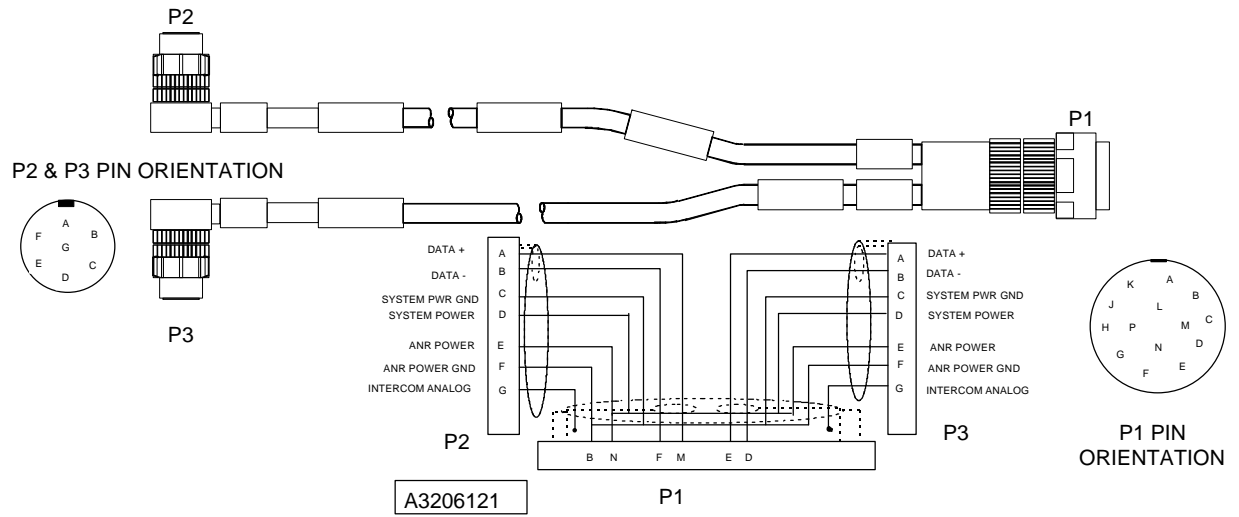
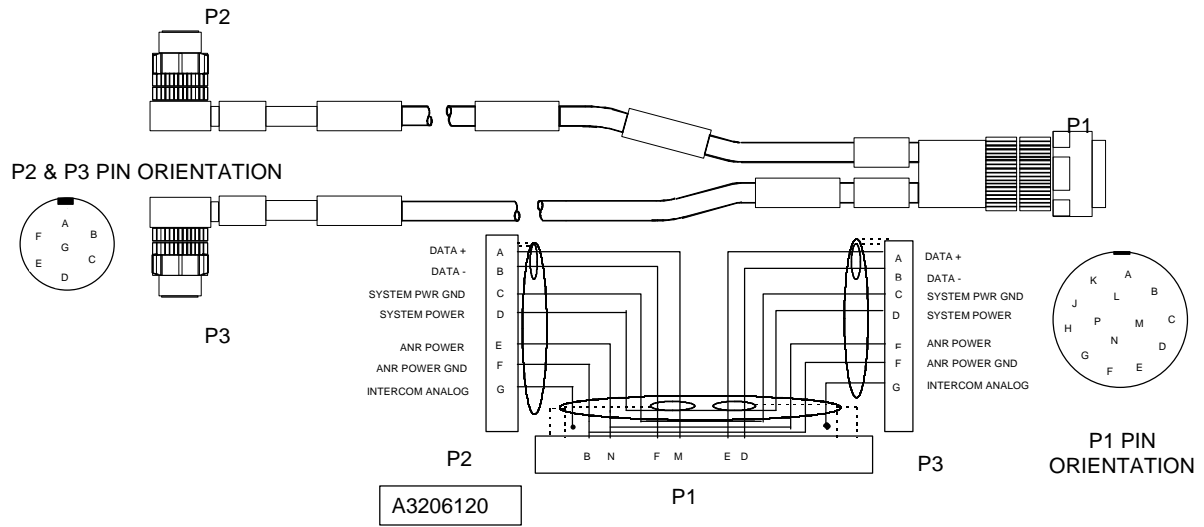

Figure-4. A3206120, A3206121, A3206127

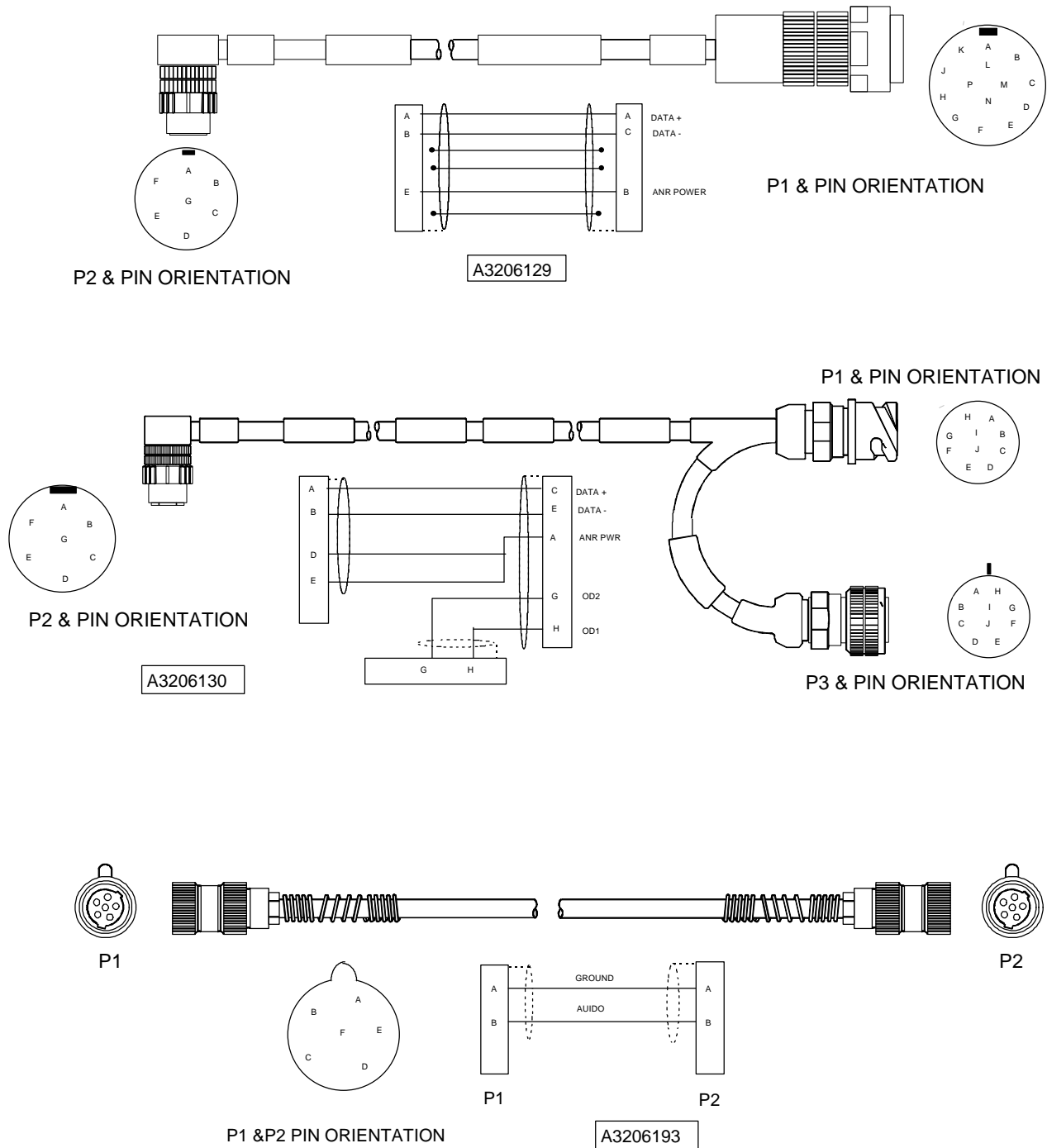

Figure-5. A3206129, A3206130, A3206193

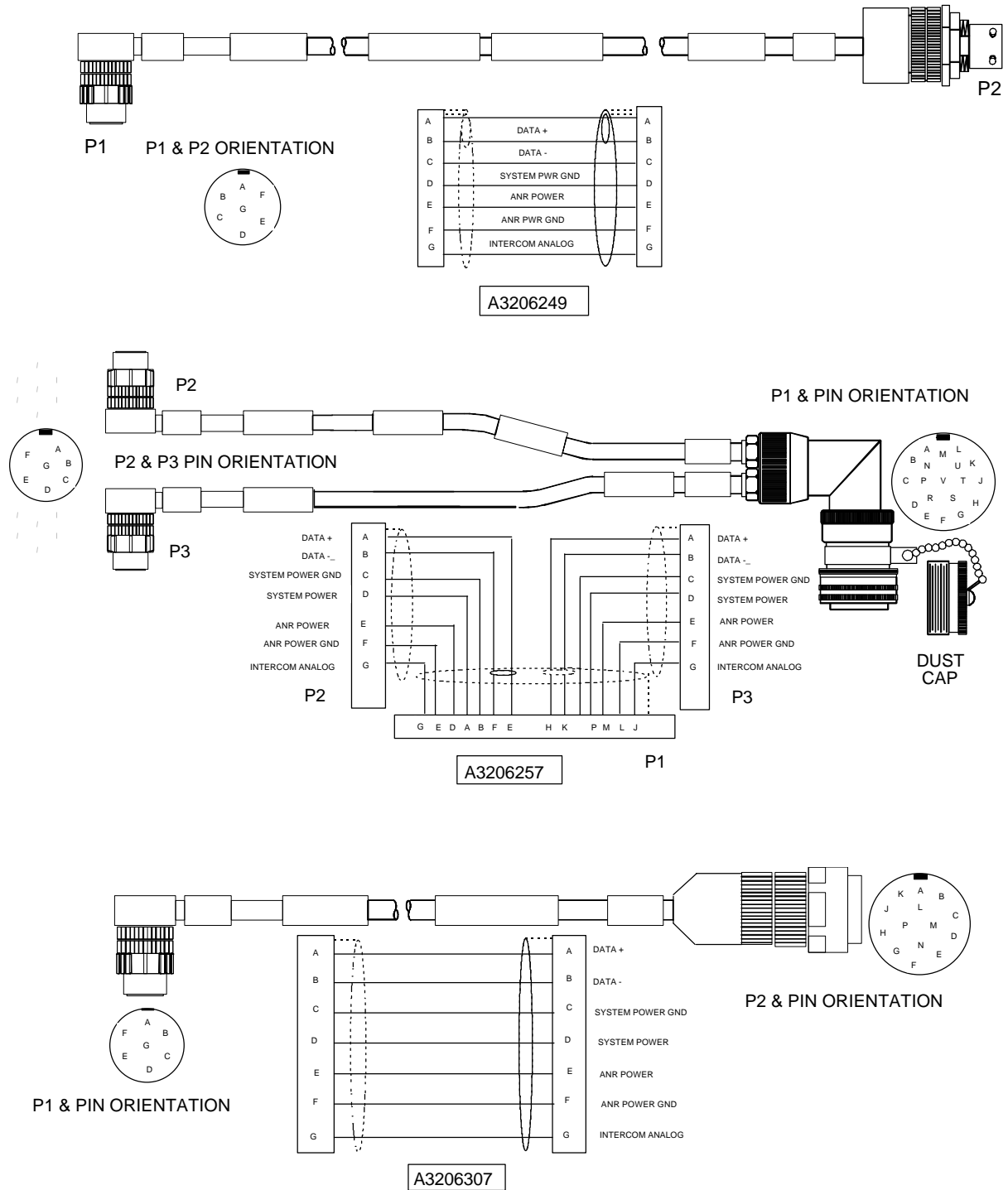
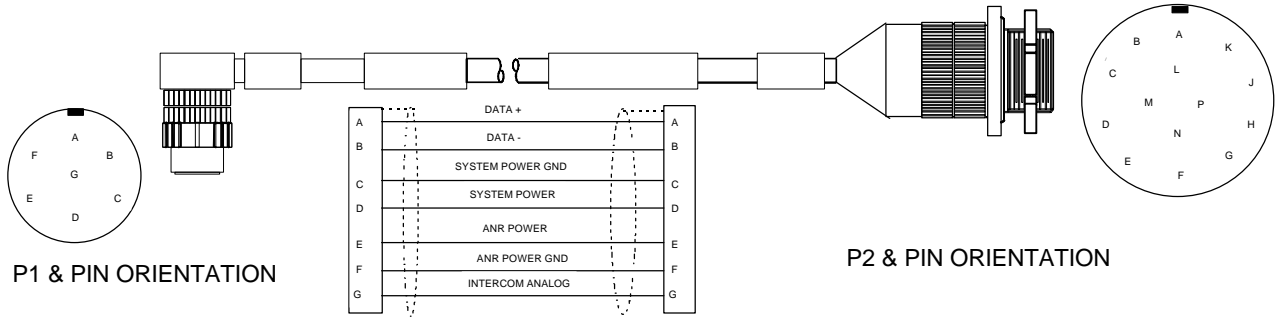
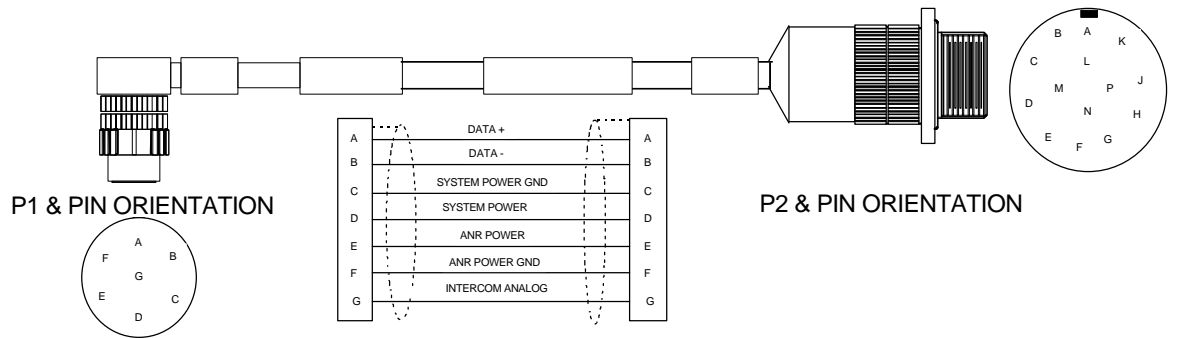

Figure-6. A3206249, A3206257, A3206307



A3206308



A3206309

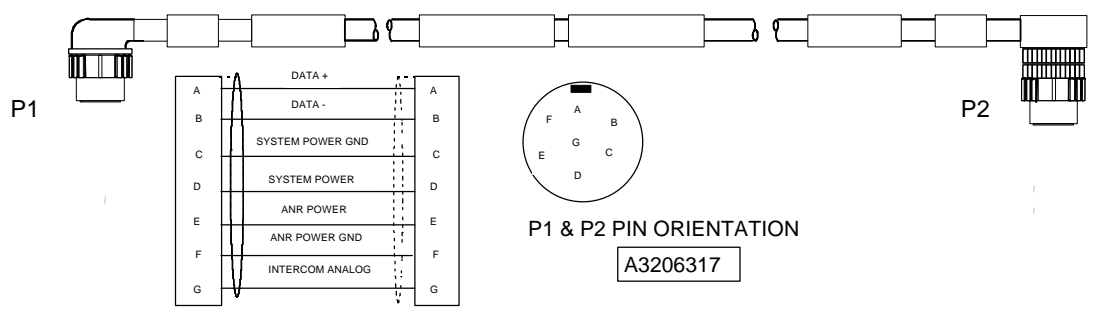

A3206317

Figure-7. A3206308, A3206309, A3206317

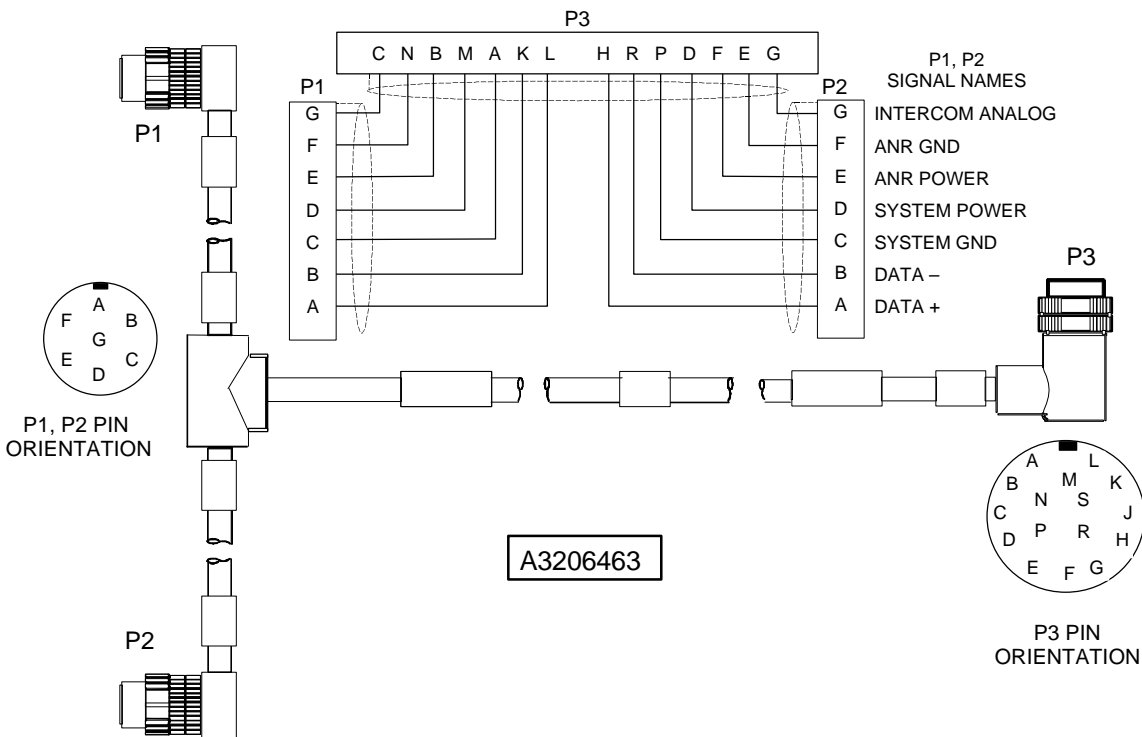
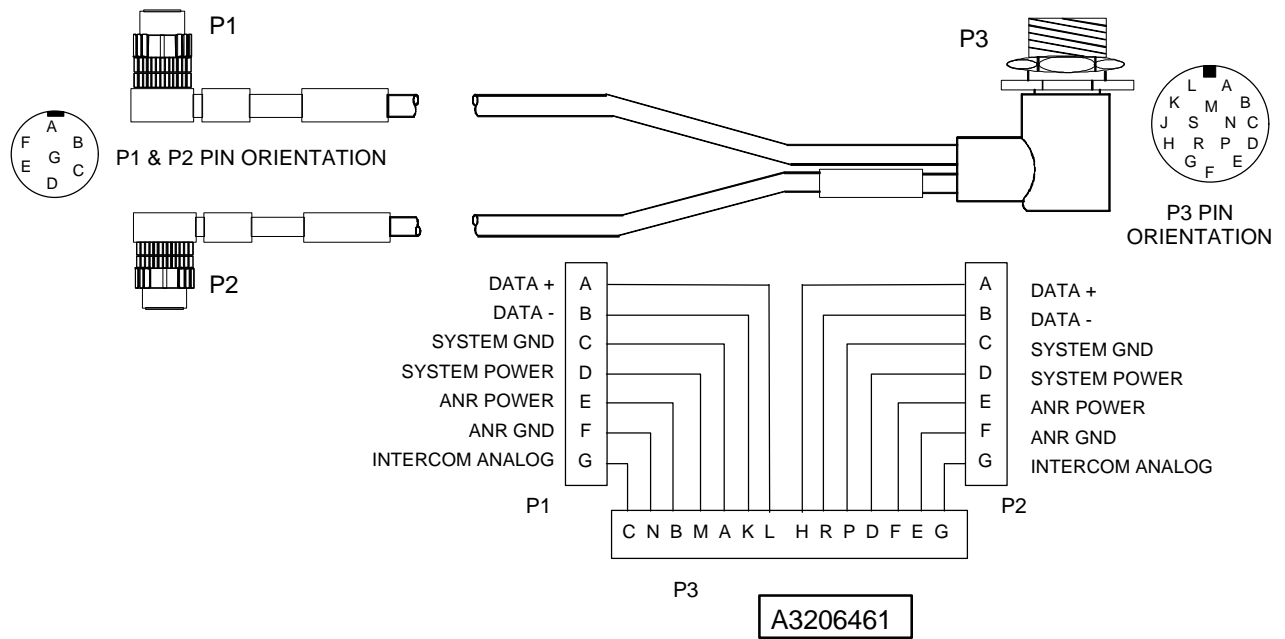
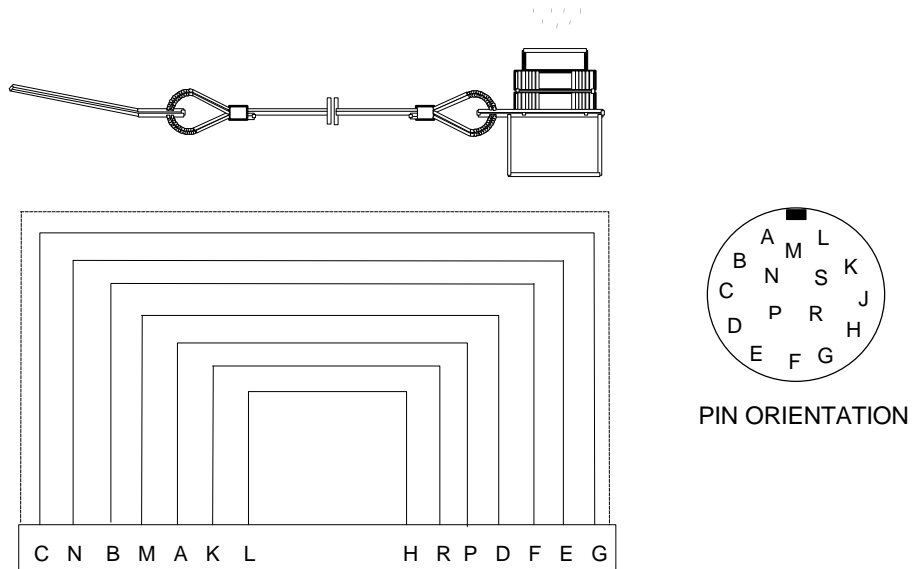

Figure-8. A3206461, A3206463



PIN IDENTIFICATION

- C AND G - INTERCOM ANALOG
- N AND E - ANR GROUND
- B AND F - ANR POWER
- M AND D - SYSTEM POWER
- A AND P - SYSTEM GND
- K AND R - DATA -
- L AND H - DATA +

Figure 9. A3206465

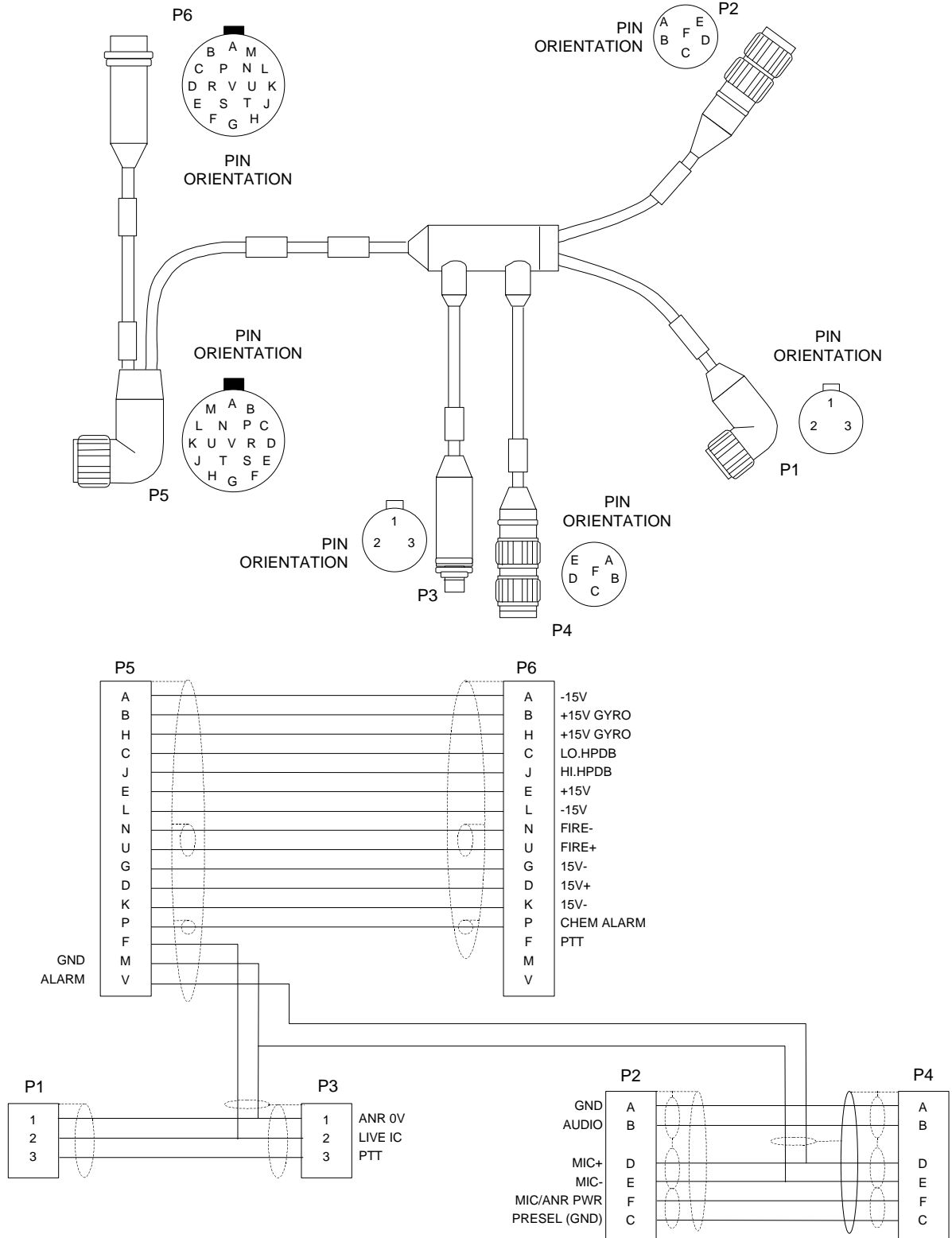

Figure 10. A3206118

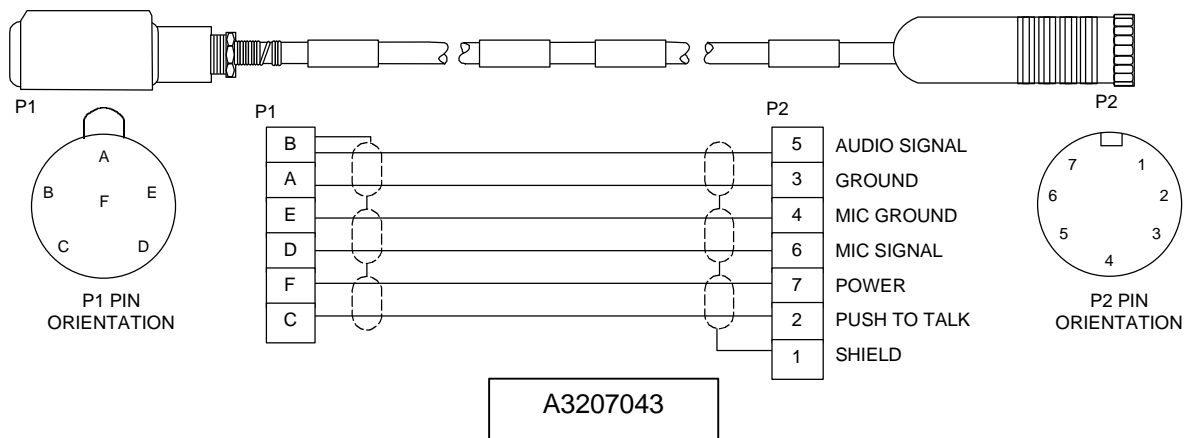
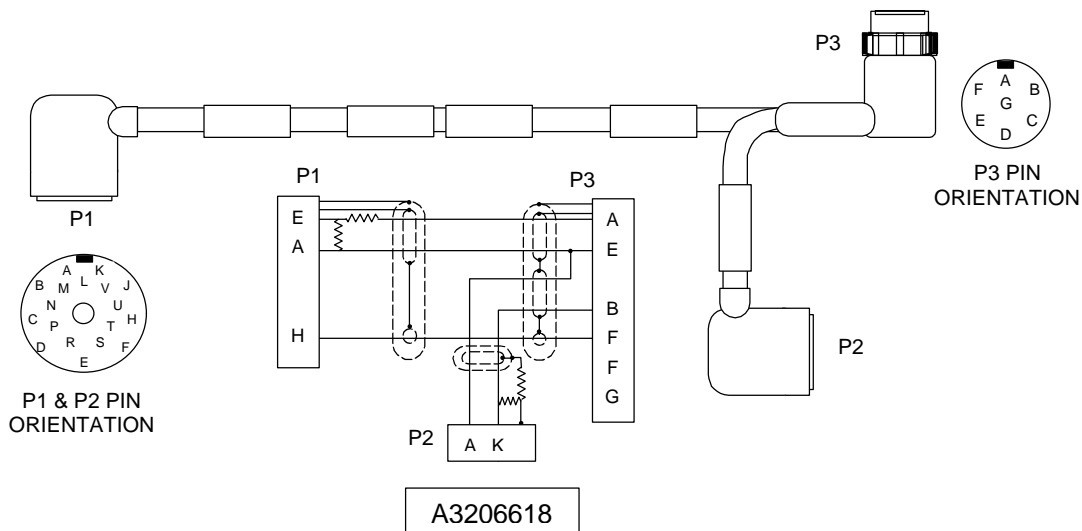

Figure 11. A3206618, A3207043

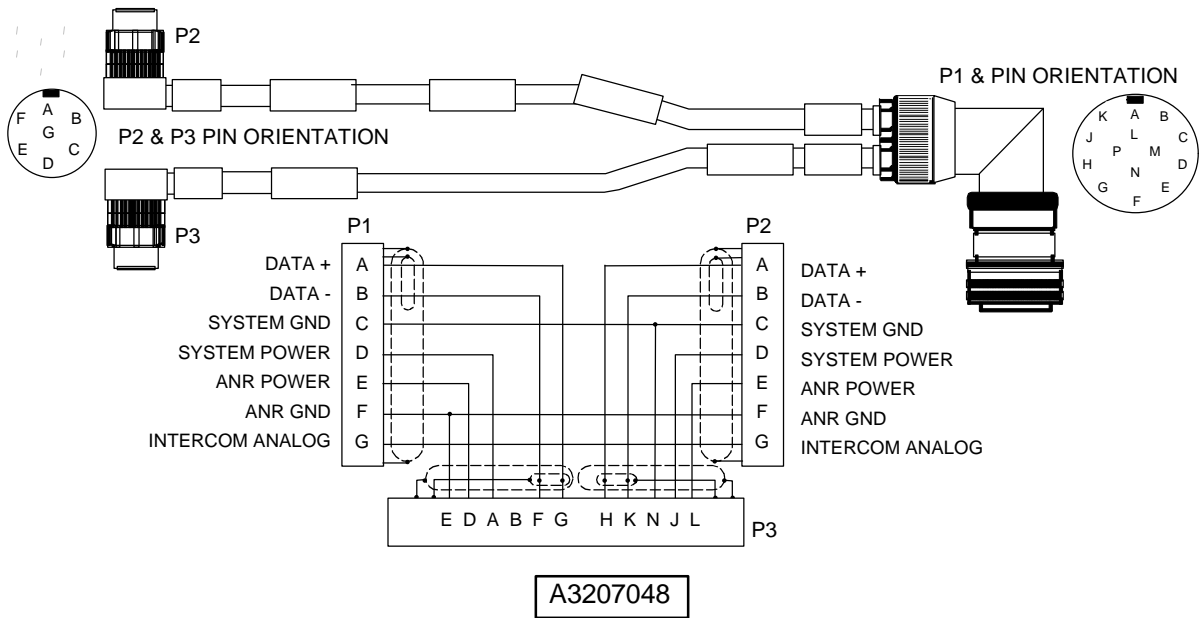
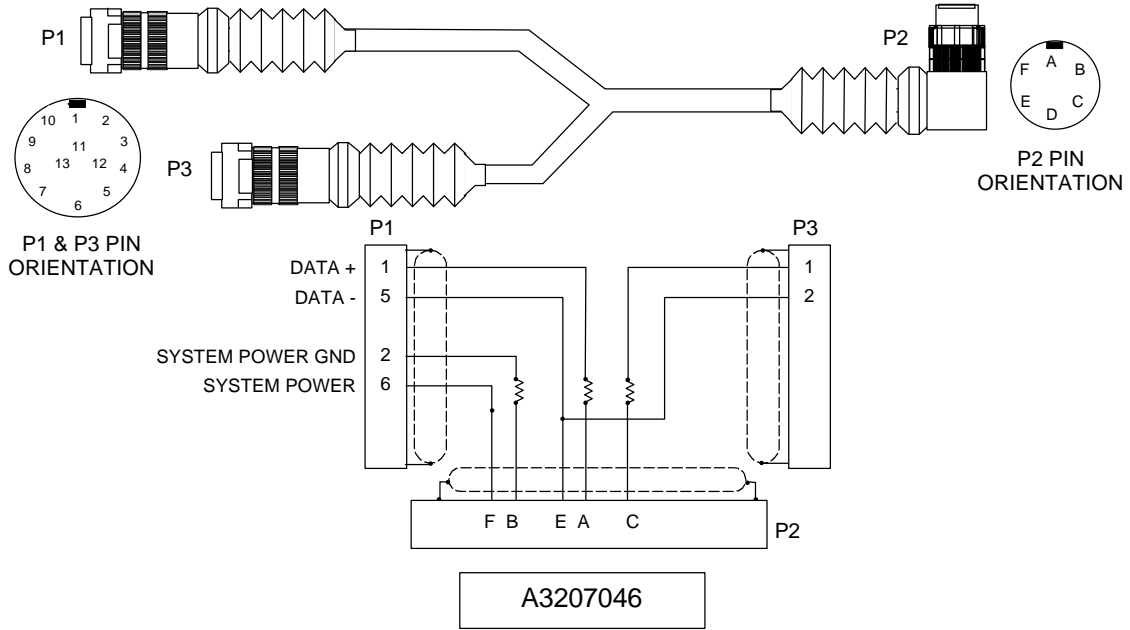

Figure 12. A3207046, A3207048

APPENDIX J

AN/VIC-3(V) TRAINING INTERFACE DEVICES

J-1 SCOPE

This appendix lists items designed to interface with existing training device(s) and the Intercommunication Set, Vehicular AN/VIC-3(V).

J2 GENERAL

The items identified herein are for reference only, and are not part of the operating system for the Intercommunication Set, Vehicular. These Cables and Adapter are used between existing training devices and the VIS LRU(s). Each cable and/or adapter is used to interface to a specific training device, as identified in paragraph J3.

J-3 DESCRIPTION OF INTERFACE DEVICE

- a. Part number. A3210696, NAME: MILES/TWGSS/PGS Adapter board. This Adapter is required when the Multiple Integrated Laser Engagement System (MILES), the Tank Weapons Gunnery Simulator System (TWGSS) or the Precision Gunnery System (PGS) training devices are to be used.
- b. Part Number. A3210697, NAME: Radio-SAWE Vehicular Intercom System, Cable Assy., Special Purpose Electrical. This Cable is required only when interface to the Situation Awareness and Weapons Effect (SAWE) is to occur.
- c. Part Number. A3210698, NAME: AN/VIC-3 Radio Interface Cable to SAWE MILES Trainer. This Cable is required when the SINCGARS Radio is to be controlled by the SAWE MILES Radio Control Device, each SINCGARS Radio will require an Interface Cable.
- d. Part Number. A3210699, NAME AN/VIC-3 Interface Cable Assy. To Thru-Sight Video. This Cable is required to exchange audio between the Thru-Sight Video (TSV) training system and the AN/VIC-3 Intercom.
- e. Part Number. A3210695, NAME AN/VIC-3 Interface Cable Assy. To SINCGARS Radio (jump-radio cable). This Cable is used for Operator training where voice transmissions are recorded.

By Order of the Secretary of the Army:

Official:

JOEL B. HUDSON
*Administrative Assistant to the
Secretary of the Army*
0008306

ERIC K. SHINSEKI
*General, United States Army
Chief of Staff*

DISTRIBUTION:

To be distributed in accordance with the initial distribution number (IDN) 361330 requirements for TM 11-5830-263-20&P.



THEN . JOT DOWN THE INFO ABOUT IT ON THIS FORM. CAREFULLY TEAR IT OUT. FOLD IT AND DROP IT IN THE MAIL.

SOMETHING WRONG WITH THIS PUBLICATION

FROM: (PRINT YOUR UNITS COMPLETE ADDRESS)
Commander
 Stateside Army Depot
 A-I-I-N: AMSTA-US
 Stateside, N.J. 07703-5007

DATE SENT
 10 July 1975

PUBLICATION NUMBER
 TM 11-5840-340-12

PUBLICATION DATE
 23 Jan 74

PUBLICATION TITLE
 Radar Set AN/PRC-76

BE EXACT PIN-POINT WHERE IT IS

IN THIS SPACE TELL WHAT IS WRONG AND WHAT SHOULD BE DONE ABOUT IT:

PAGE NO	PARA GRAPH	FIGURE NO	TABLE NO
---------	------------	-----------	----------

2-25

2-28

Recommend that the installation antenna alignment procedure be changed throughout to specify a 20 IFF antenna lag rather than 10.

REASON: Experience has shown that with only a 10 lag, the antenna servo system is too sensitive to wind gusting in excess of 25 knots, and has a tendency to rapidly accelerate and decelerate as it hunts, causing stress to the drive train. Hunting is minimized by adjusting the lag to 20 without degradation of operation.

3-10

3-3

3-1

Item 5, Functional Test Plan. Change \square 2 dB" to \square 3 dB".

REASON: The adjustment procedure for the TRANS POWER FAULT indicator calls for a 3 dB (500 watts) adjustment to light the TRANS POWER FAULT indicator.

5-6

5-8

new step f.1 to read, \square Replace cover plate removed in step above."

REASON: To replace the cover plate.

FO-3

Zone C 3. On J1-2, change \square +24 VDC" to \square +5 VDC".

REASON: This is the output line of the 5 VDC power supply. +24 VDC is the input voltage.

TEAR ALONG DOTTED LINE

PRINTED NAME, GRADE OR TITLE AND TELEPHONE NUMBER

SSG I. M. DeSpirito 999-1776

SIGN HERE

SOMETHING WRONG WITH THIS PUBLICATION



THEN... JOT DOWN THE INFO ABOUT IT ON THIS FORM. CAREFULLY TEAR IT OUT. FOLD IT AND DROP IT IN THE MAIL.

FROM: (PRINT YOUR UNIT'S COMPLETE ADDRESS)

DATE SENT

PUBLICATION NUMBER

PUBLICATION DATE

PUBLICATION TITLE

I

BE EXACT PIN-POINT WHERE IT IS

IN THIS SPACE TELL WHAT IS WRONG AND WHAT SHOULD BE DONE ABOUT IT:

PAGE NO

PARA GRAPH

FIGURE NO

TABLE NO

TEAR ALONG DOTTED LINE

PRINTED NAME, GRADE OR TITLE AND TELEPHONE NUMBER

SIGN HERE

FILL IN YOUR
UNIT'S ADDRESS

FOLD BACK

DEPARTMENT OF THE ARMY

PLEASE
AFFIX
STAMP
POSTAGE
REQUIRED

OFFICIAL BUSINESS

Commander
U.S. Army Communications-Electronics Command
and Fort Monmouth
ATTN: AMSEL-LC-LEO-D-CS-CFO
Fort Monmouth, New Jersey 07703-5000

TEAR ALONG DOTTED LINE

THE METRIC SYSTEM AND EQUIVALENTS

WEIGHT MEASURE

1 Centimeter = 10 Millimeters = 0.01 Meters = 0.3937 Inches
 1 Meter = 100 Centimeters = 1000 Millimeters = 39.37 Inches
 1 Kilometer = 1000 Meters = 0.621 Miles

WEIGHTS

1 Gram = 0.001 Kilograms = 1000 Milligrams = 0.035 Ounces
 1 Kilogram = 1000 Grams = 2.2 lb.
 1 Metric Ton = 1000 Kilograms = 1 Megagram = 1.1 Short Tons

LIQUID MEASURE

1 Milliliter = 0.001 Liters = 0.0338 Fluid Ounces
 1 Liter = 1000 Milliliters = 33.82 Fluid Ounces

SQUARE MEASURE

1 Sq. Centimeter = 100 Sq. Millimeters = 0.155 Sq. Inches
 1 Sq. Meter = 10,000 Sq. Centimeters = 10.76 Sq. Feet
 1 Sq. Kilometer = 1,000,000 Sq. Meters = 0.386 Sq. Miles

CUBIC MEASURE

1 Cu. Centimeter = 1000 Cu. Millimeters = 0.06 Cu. Inches
 1 Cu. Meter = 1,000,000 Cu. Centimeters = 35.31 Cu. Feet

TEMPERATURE

$5/9(^{\circ}\text{F} - 32) = ^{\circ}\text{C}$
 212° Fahrenheit is equivalent to 100° Celsius
 90° Fahrenheit is equivalent to 32.2° Celsius
 32° Fahrenheit is equivalent to 0° Celsius
 $9/5^{\circ}\text{C} + 32 = ^{\circ}\text{F}$

APPROXIMATE CONVERSION FACTORS

TO CHANGE	TO	MULTIPLY BY
Inches	Centimeters	2.540
Feet	Meters	0.305
Yards	Meters	0.914
Miles	Kilometers	1.609
Square Inches	Square Centimeters	6.451
Square Feet	Square Meters	0.093
Square Yards	Square Meters	0.836
Square Miles	Square Kilometers	2.590
Acres	Square Hectometers	0.405
Cubic Feet	Cubic Meters	0.028
Cubic Yards	Cubic Meters	0.765
Fluid Ounces	Milliliters	29.573
its	Liters	0.473
arts	Liters	0.946
allons	Liters	3.785
Ounces	Grams	28.349
Pounds	Kilograms	0.454
Short Tons	Metric Tons	0.907
Pound-Feet	Newton-Meters	1.356
Pounds per Square Inch	Kilopascals	6.895
Miles per Gallon	Kilometers per Liter	0.425
Miles per Hour	Kilometers per Hour	1.609

TO CHANGE	TO	MULTIPLY BY
Centimeters	Inches	0.394
Meters	Feet	3.280
Meters	Yards	1.094
Kilometers	Miles	0.621
Square Centimeters	Square Inches	0.155
Square Meters	Square Feet	10.764
Square Meters	Square Yards	1.196
Square Kilometers	Square Miles	0.386
Square Hectometers	Acres	2.471
Cubic Meters	Cubic Feet	35.315
Cubic Meters	Cubic Yards	1.308
Milliliters	Fluid Ounces	0.034
Liters	Pints	2.113
Liters	Quarts	1.057
ers	Gallons	0.264
ms	Ounces	0.035
ograms	Pounds	2.205
Metric Tons	Short Tons	1.102
Newton-Meters	Pounds-Feet	0.738
Kilopascals	Pounds per Square Inch	0.145
ometers per Liter	Miles per Gallon	2.354
ometers per Hour	Miles per Hour	0.621

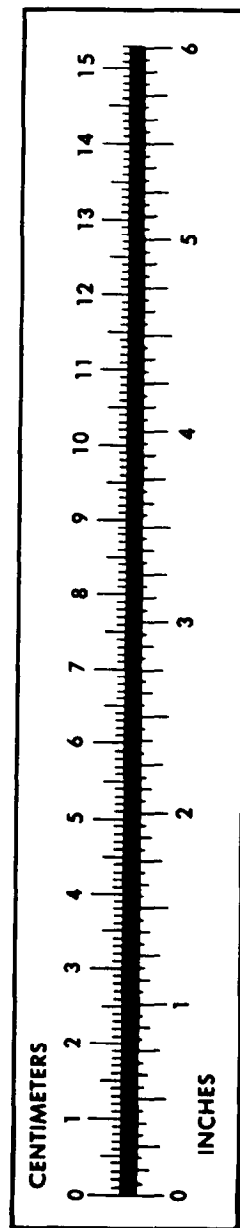

PIN: 077912-000